



AUTOMOTIVE PRODUCTS,

INSTALLATION INSTRUCTIONS

PRO TRAXX 4 OVAL TUBE STEP BAR

APPLICATION:

2007-2013 Chevrolet Silverado / GMC Sierra 1500 Crew / Ext. Cab
2008-2014 Chevrolet Silverado / GMC Sierra 2500/3500HD Crew / Ext. Cab (Excludes 2011-2014 Diesel Models)

PART NUMBER:

21-21680, 21-21685, 21-21950, 21-21955

ITEM	QUANTITY	DESCRIPTION	TOOLS NEEDED
1,2	2	STEP BAR, DRIVER(1) AND PASSENGER(2)	13MM SOCKET
3	6	MOUNTING BRACKETS	HEX KEY TOOL
4	6	M8 HEX CAP SCREW (YELLOW ZINC)	RATCHET
5	6	M8 FLAT WASHER (YELLOW ZINC)	TORQUE WRENCH
6	6	M8 SPRING LOCK WASHER (YELLOW ZINC)	
7	12	M10 BUTTON HEAD SOCKET CAP SCREW (BLACK ZINC)	
8	12	M10 FLAT WASHER (BLACK ZINC)	
9	12	M10 INTERNAL TOOTHED LOCK WASHER (BLACK ZINC)	
10	12	M8 EXTRUDED U-NUT (YELLOW ZINC)	
11	6	M8 FLANGED HEX CAP SCREW (YELLOW ZINC)	
12	6	M8 EXTERNAL TOOTHED LOCK WASHER (YELLOW ZINC)	
13	12	M6 HEX HEAD CAP SCREW (YELLOW ZINC)	
14	24	M6 FLAT WASHER (YELLOW ZINC)	
15	12	M6 NYLON NUT (YELLOW ZINC)	
16	6	PLASTIC BRACKET COVER	

ANTI-SEIZE LUBRICANT MUST BE USED ON ALL STAINLESS STEEL FASTENERS TO PREVENT THREAD DAMAGE AND GALLING

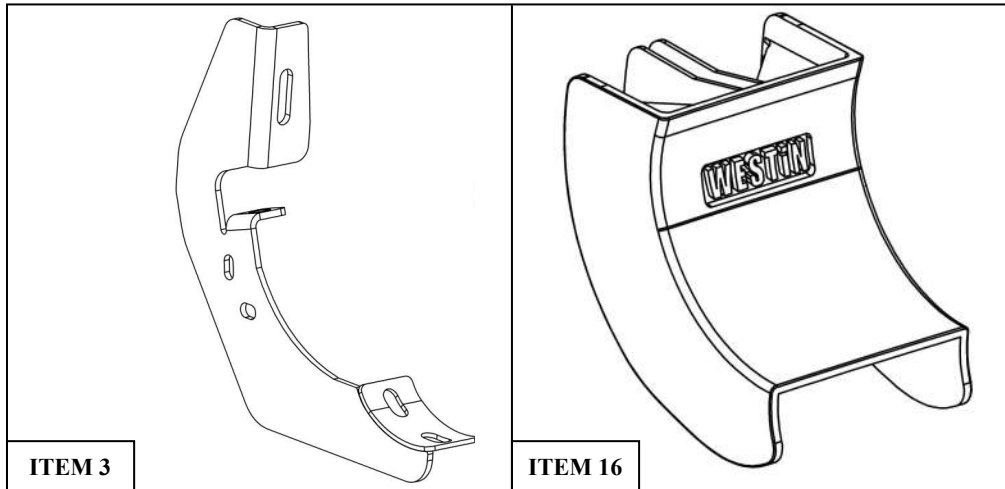

PROCEDURE

1. Remove contents from box, verify if all parts listed are present and free from damage. Carefully read and understand all instructions before attempting installation.
Failure to identify damage before installation could lead to a rejection of any claim.



Westin Automotive Products, Inc.
320 W. Covina Blvd
San Dimas, Ca. 91773

2. **FOR 09-12 CREW CAB:** Starting from the drivers side of the vehicle locate the threaded hole located in the rocker panel towards the front of the vehicle. Take (1) mounting bracket and attach it to the threaded hole using (1) M8 hex head bolt, (1) M8 lock washer, and (1) M8 flat washer . Locate the existing welded nut on the pinch weld and attach the mounting bracket to the pinch weld using (1) M8 flange bolt, and (1) M8 toothed lock washer. See **Figures 1 and 2**. *Do not fully tighten at this time.*
3. Move to the next threaded hole in the rocker panel and repeat **Step 2**.
4. Remove the rubber plug from the bigger hole to access the smaller OD hole, and insert (1) M8 nut clip over the hole, attach (1) mounting bracket to the previously installed nut clip using (1) M8 hex head bolt, (1) M8 lock washer, and (1) M8 flat washer. Locate the existing hole in the pinch weld and place (1) M8 extruded u-nut onto the hole, attach the mounting bracket to the pinch weld using (1) M8 flange bolt, and (1) M8 toothed lock washer. See **Figures 3 and 4**. *Do not fully tighten at this time.*
5. Repeat **Steps 2-4** for the passenger side.
6. Locate (1) plastic bracket cover (Item 16) and loosely secure it to the (4) brackets using the provided hardware: (2) M6 hex head cap screws, (4) M6 flat washers, and (2) M6 nylon nuts. Repeat for every bracket. See **Figure 5**.
7. Take the drivers side step bar and place it on the mounting cradles attach the step bar using (6) M10 button head bolts, (6) M10 toothed lock washers, and (6) M10 flat washers. See **Figure 6**. Repeat this step for the passenger side.
8. Align and adjust as needed then tighten all hardware at this time. Torque all M8 hardware to 15-18 ft lbs, M10 to 30-35 ft-lbs, and M6 to 5-7 ft-lbs.

2. **FOR 09-12 EXTENDED CAB:** Starting at the drivers side of the vehicle locate the existing circular hole in the rocker panel towards the front of the vehicle. Remove the rubber plug from the bigger hole to access the smaller OD hole and insert (1) M8 nut clip over the hole, attach (1) mounting bracket to the previously installed nut clip using (1) M8 hex head bolt, (1) M8 lock washer, and (1) M8 flat washer. Locate the existing hole in the pinch weld and place (1) M8 clip nut onto the hole, attach the mounting bracket to the pinch weld using (1) M8 flange bolt, and (1) M8 toothed lock washer. See **Figures 3 and 4**. *Do not fully tighten at this time.*
3. Repeat **Step 2** for all of the mounting locations on the drivers side and passenger side.
4. Locate (1) plastic bracket cover (Item 16) and loosely secure it to the (4) brackets using the provided hardware: (2) M6 hex head cap screws, (4) M6 flat washers, and (2) M6 nylon nuts. Repeat for every bracket. See **Figure 5**.
5. Take the drivers side step bar and place it on the mounting cradles attach the step bar using (6) M10 button head bolts, (6) M10 toothed lock washers, and (6) M10 flat washers. See **Figure 6**. Repeat this step for the passenger side.
6. Align and adjust as needed then tighten all hardware at this time. Torque all M8 hardware to 15-18 ft lbs, M10 to 30-35 ft-lbs, and M6 to 5-7 ft-lbs.

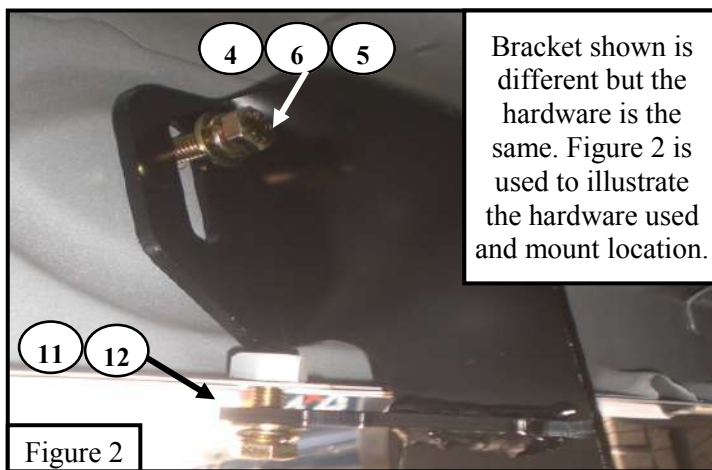
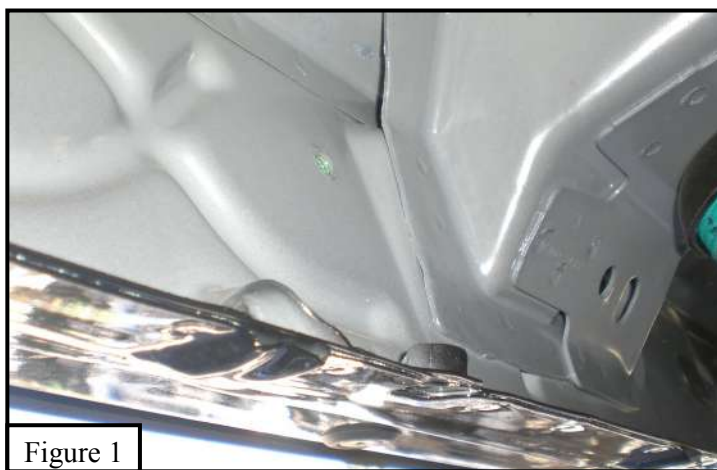

Bracket shown is different but the hardware is the same. Figure 2 is used to illustrate the hardware used and mount location.



Westin Automotive Products, Inc.
320 W. Covina Blvd
San Dimas, Ca. 91773

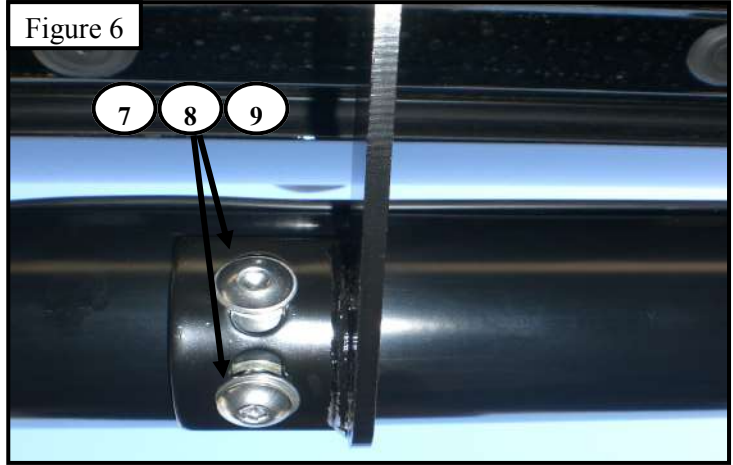
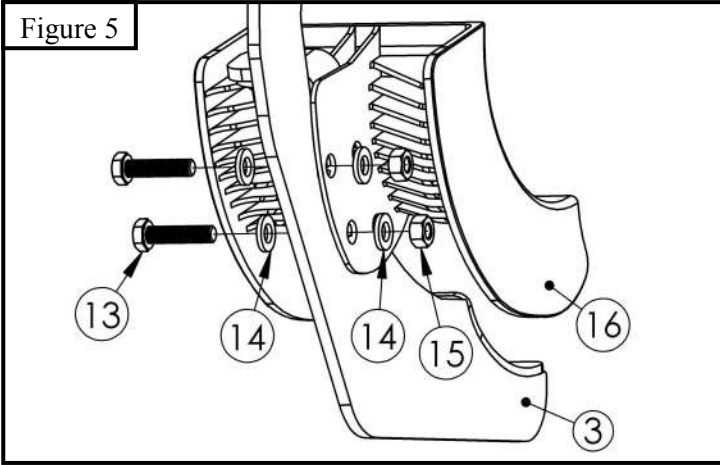
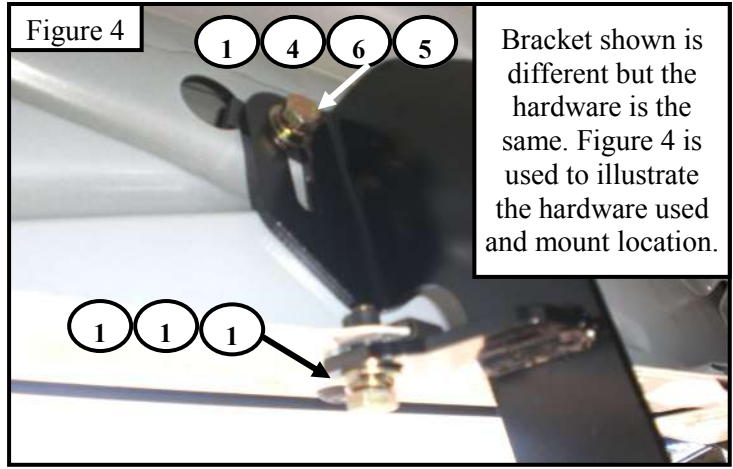
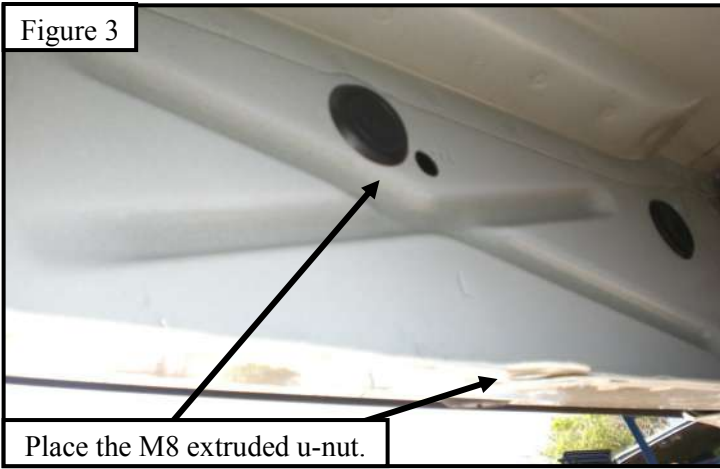

Care Instructions

- REGULAR WAXING IS RECOMMENDED. DO NOT USE ANY TYPE OF POLISH OR WAX THAT MAY CONTAIN ABRASIVES.
- STAINLESS STEEL PRODUCTS CAN BE CLEANED WITH MILD SOAP AND WATER. STAINLESS STEEL POLISH SHOULD BE USED TO POLISH SMALL SCRATCHES.
- GLOSS BLACK FINISHES SHOULD BE CLEANED WITH MILD SOAP AND WATER.



Westin Automotive Products, Inc.
 320 W. Covina Blvd
 San Dimas, Ca. 91773

Thank you for choosing Westin products
 for additional installation assistance please call
 Customer Service (800) 793-7846
 www.westinautomotive.com

Westin

SIGNATURE OF QUALITY

AUTOMOTIVE PRODUCTS, INC.



WARNING



Failure to follow these instructions could lead to death, personal injury, and / or property damage.

FASTENERS:

All Westin supplied fasteners must be utilized and installed in accordance with the installation instructions and apply torque to the specifications as defined. **DOUBLE CHECK ALL FASTENERS BEFORE INITIAL USE, AND PERIODICALLY IN THE FUTURE TO ENSURE PROPER FUNCTION AND SAFETY.**

DRILLING:

Most Westin products do not require drilling for installation. If drilling is defined as required, use caution when drilling a vehicle. **FAILURE TO REVIEW AN AREA TO BE DRILLED MAY RESULT IN PERSONAL INJURY AND/OR INJURY TO OTHERS AS WELL AS VEHICLE DAMAGE.**

EYE PROTECTION:

ALWAYS WEAR SAFETY GLASSES OR GOGGLES DURING THE INSTALLATION PROCESS TO AVOID PERSONAL INJURY.

MAXIMUM TOWING/CARRYING CAPACITY:

The Westin Receiver Hitches will have a visible tow rating label affixed directly on the product. User should never exceed the vehicle manufacturers maximum tow and weight rating regardless of the capacity of the hitch. **FAILURE TO FOLLOW THESE GUIDELINES WILL VOID THE WESTIN WARRANTY AND MAY RESULT IN PERSONAL INJURY AND/OR INJURY TO OTHERS AS WELL AS VEHICLE DAMAGE.**

Westin
SIGNATURE OF QUALITY

Westin Automotive Products, Inc.
320 W. Covina Blvd
San Dimas, Ca. 91773