



AUTOMOTIVE PRODUCTS,

# INSTALLATION INSTRUCTIONS

## PRO TRAXX 4 OVAL TUBE STEP BAR

### APPLICATION:

2009-2016 Dodge Ram 1500 Quad / Crew Cab  
2009-2016 Dodge Ram 2500/3500 HD Crew Cab

### PART NUMBER:

21-23550, 21-23555, 21-23560, 21-23565

ITEM	QUANTITY	DESCRIPTION	TOOLS NEEDED
1,2	2	STEP BAR, DRIVER(1) AND PASSENGER(2)	13MM SOCKET
3	2	MOUNTING BRACKET A	17MM SOCKET
4	3	MOUNTING BRACKET B	ALLEN KEY
5	1	MOUNTING BRACKET C	3/8" WRENCH
6	5	M10 / M8 NUT PLATE (YELLOW ZINC)	DRILL
7	12	M8 HEX HEAD BOLT (YELLOW ZINC)	1/4" DRILL BIT
8	12	M8 FLAT WASHER (YELLOW ZINC)	RATCHET
9	12	M8 SPLIT LOCK WASHER (YELLOW ZINC)	TORQUE WRENCH
10	7	M8 RIV-CERTS (YELLOW ZINC)	
11	5	M10 FLAT WASHER (YELLOW ZINC)	
12	5	M10 HEX NUT (YELLOW ZINC)	
13	5	M10 LOCK WASHER (YELLOW ZINC)	
14	12	M10 BUTTON HEAD BOLT (BLACK STAINLESS STEEL)	
15	12	M10 FLAT WASHER (BLACK STAINLESS STEEL)	
16	12	M10 INTERNAL TOOTH LOCK WASHER (BLACK STAINLESS STEEL)	
17	5	M10 PLASTIC RETAINER	
18	2	M6 BUTTON HEAD BOLTS (STAINLESS STEEL)	
19	2	M6 FLAT WASHERS (STAINLESS STEEL)	
20	2	M6 SERRATED FLANGE NUT (STAINLESS STEEL)	
21	12	M6 HEX HEAD CAP SCREW (BLACK STAINLESS STEEL)	
22	24	M6 FLAT WASHER (BLACK STAINLESS STEEL)	
23	12	M6 NYLON NUT (BLACK STAINLESS STEEL)	
24	6	PLASTIC BRACKET COVER	

**ANTI-SEIZE LUBRICANT MUST BE USED ON ALL STAINLESS STEEL FASTENERS TO PREVENT THREAD DAMAGE AND GALLING**

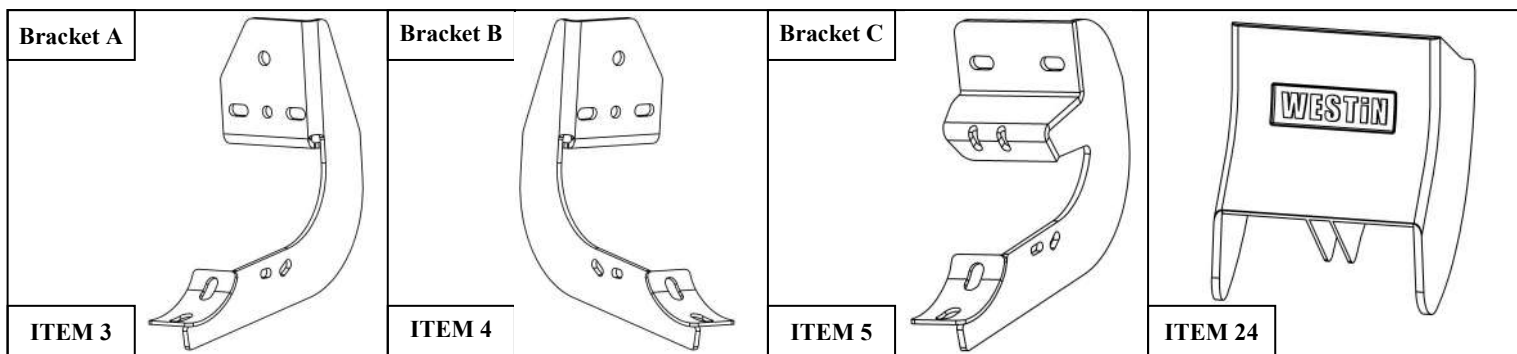

Westin Automotive Products, Inc.  
320 W. Covina Blvd  
San Dimas, Ca. 91773

## PROCEDURE

1. Remove contents from box, verify if all parts listed are present and free from damage.  
Carefully read and understand all instructions before attempting installation.  
**Failure to identify damage before installation could lead to a rejection of any claim.**
2. Check either side of the vehicles rocker panel, locate the factory holes in the rocker panel by removing the tape. Check and verify what type of rocker panel you have. **See Figures 1, 2, 3, & 4. Note:** If any of the locations on the factory holes in the rocker panel have factory M8 riv-certs or threaded M8 holes, do not use provided M8 riv-certs (Item 10) in that location.  
**Refer to Figures 2, 3, & 4.**
3. **Starting from the driver side:** If the threaded holes are not present use (2) M8 riv-certs (Item 10) and insert them into the hex holes. **Note:** See **Figure 6** for example on how to tighten M8 riv-certs, it will require to use an M10 bolt with M8 nut plate (Item 6) along with bracket (Item 4) to perform this task. Use **Figure 8** on how to position (Item 6). This procedure will permanently install M8 riv-cert. Remove (Item 6) after the riv-certs are tightened.
4. Proceed to install the mounting bracket "C" (Item 5) onto the rocker panel by using (2) M8 hex bolts (Item 7), (2) M8 lock washers (Item 9), (2) flat washers (Item 8). For the pinch weld, attach bracket (Item 5) by using (2) M6 Button head bolts (Item 18), (2) M6 flat washers (Item 19) & (2) M6 serrated flange nuts. **Note:** Drilling of two 1/4" holes might be necessary on pinch weld if factory holes are not present. Before drilling place masking tape on drill surface to prevent paint chipping. **See Figures 9 & 10.**
5. On the middle mounting location of drivers side attach (1) M8 riv-cert to rocker panel if not already present. Then proceed to install (1) M10 bolt/M8 nut plate (Item 6) into the rocker panel and thread (1) M10 plastic retainer (Item 17) to the M10 bolt to prevent it from falling into the rocker panel. **See Figure 5.**

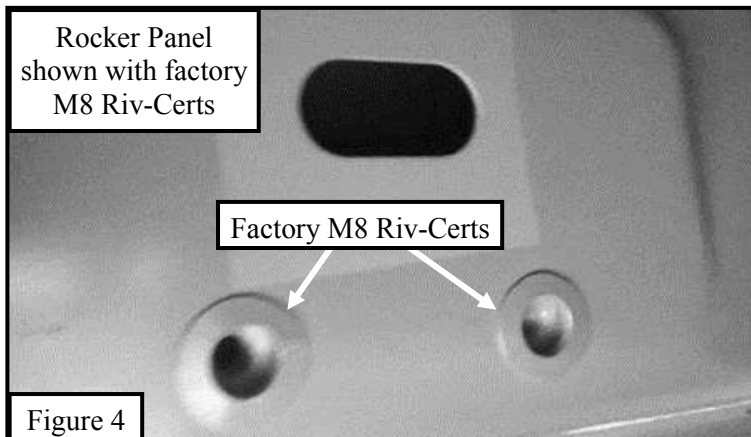
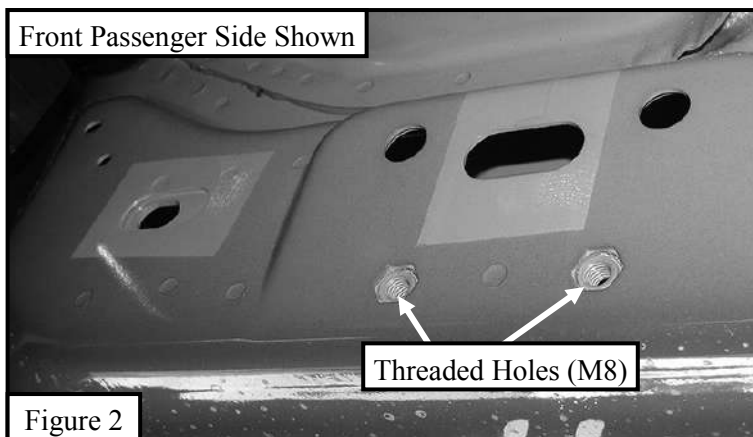
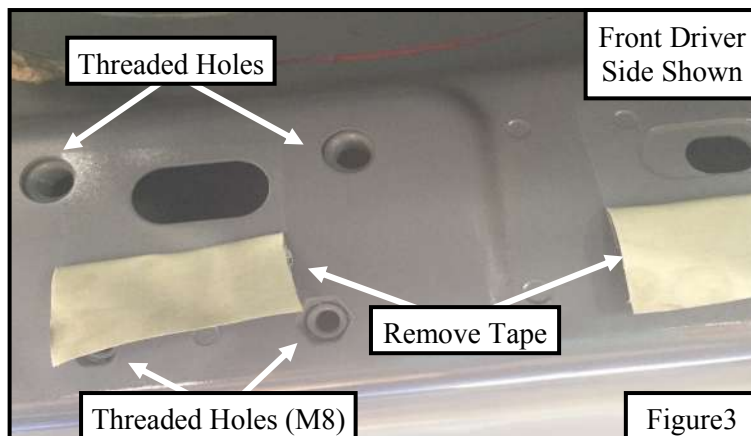

Westin Automotive Products, Inc.  
320 W. Covina Blvd  
San Dimas, Ca. 91773

6. Attach mounting bracket "A" (Item 3) to the rocker panel by first tightening the M8 riv-cert into place. See **Figure 6**. Then continue by attaching mounting bracket "A" (Item 3) and aligning (Item 6) (as shown on **Figure 5**), using (2) M8 Hex bolts (Item 7), (2) M8 Lock Washers (Item 9), (2) M8 Flat washers (Item 8), (1) M10 flat washer (Item 11), (1) M10 lock washer (Item 13) & (1) M8 Hex nut (Item 12). Leave everything loose at this time. See **Figure 11**.
7. For rear mounting bracket installation of the drivers side use mounting bracket "B" (Item 4) bracket and the same installation procedure as step 6.
8. **Starting from the Passenger side:** Insert (1) M10 bolt/M8 nut plate (Item 6) into the rocker panel and thread (1) M10 plastic retainer (Item 17) to the M10 bolt to prevent it from falling into the rocker panel. See **Figure 5**.
9. If the front of the rocker panel has pre-installed M8 riv-certs, the M10/M8 plate (Item 6) will need to be positioned as shown in **Figure 8**.
10. If the front rocker panel does not have pre-installed M8 riv-certs then (Item 6) will be used as shown on **Figures 5 & 11**.
11. Attach mounting bracket "B" (Item 4) to passenger front and center locations & mounting bracket "A" (Item 3) to passenger rear using the same procedure as step 6.
12. Locate (1) plastic bracket cover (Item 24) and loosely secure it to the (6) brackets using the provided hardware: (2) M6 hex head cap screws, (4) M6 flat washers, and (2) M6 nylon nuts. Repeat for every bracket. See **Figure 12**.
13. Attach step bars (Items 1 & 2) respectively to either side using (6) M10 button head bolts (Item 14), (6) M10 internal toothed lock washers (Item 16) & (6) M10 flat washers (Item 15). See **Figures 13 & 14**.
14. Align and adjust the step bars as needed then fully tighten all hardware at this time. Torque all M10 fasteners to 30-35 ft-lbs, M8 to 15-18 ft-lbs, and M6 to 5-7 ft-lbs.

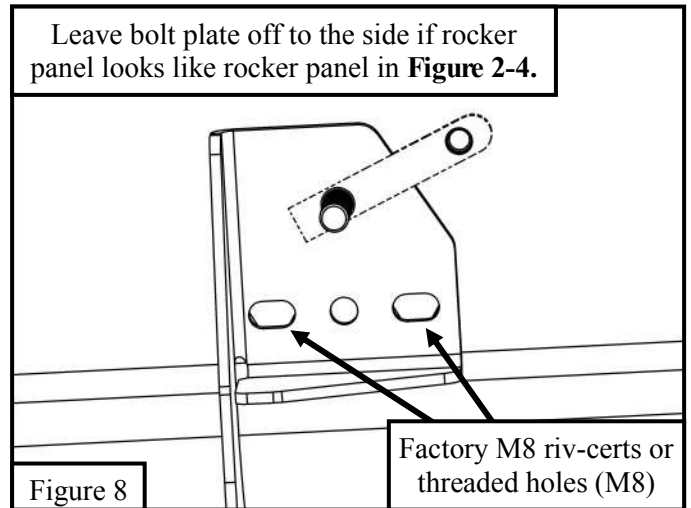
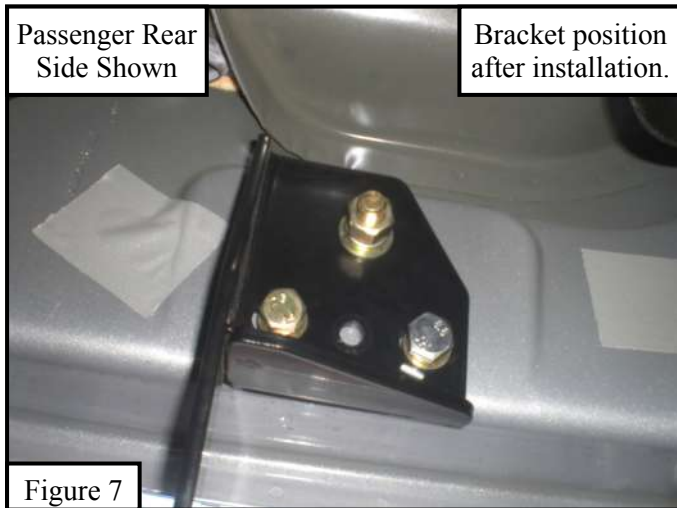
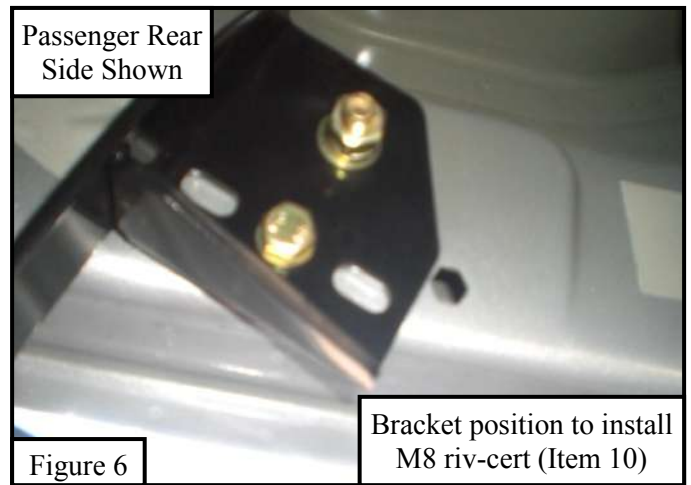
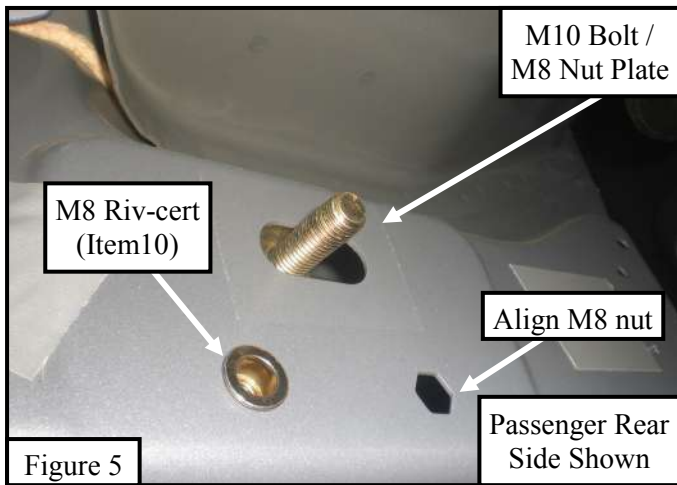

Westin Automotive Products, Inc.  
320 W. Covina Blvd  
San Dimas, Ca. 91773

Thank you for choosing Westin products  
for additional installation assistance please call  
Customer Service (800) 793-7846

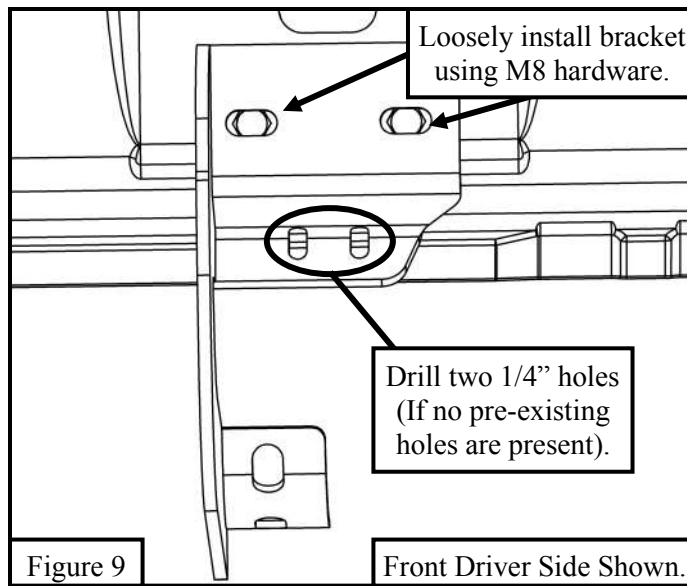
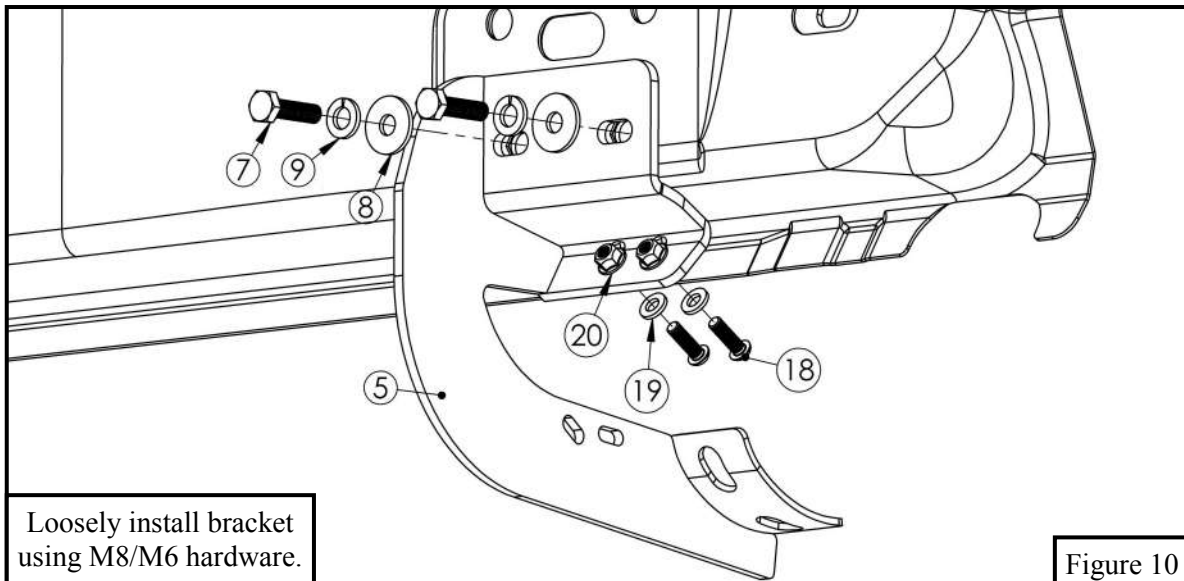

Figure 9

Front Driver Side Shown.



Loosely install bracket using M8/M6 hardware.

Figure 10

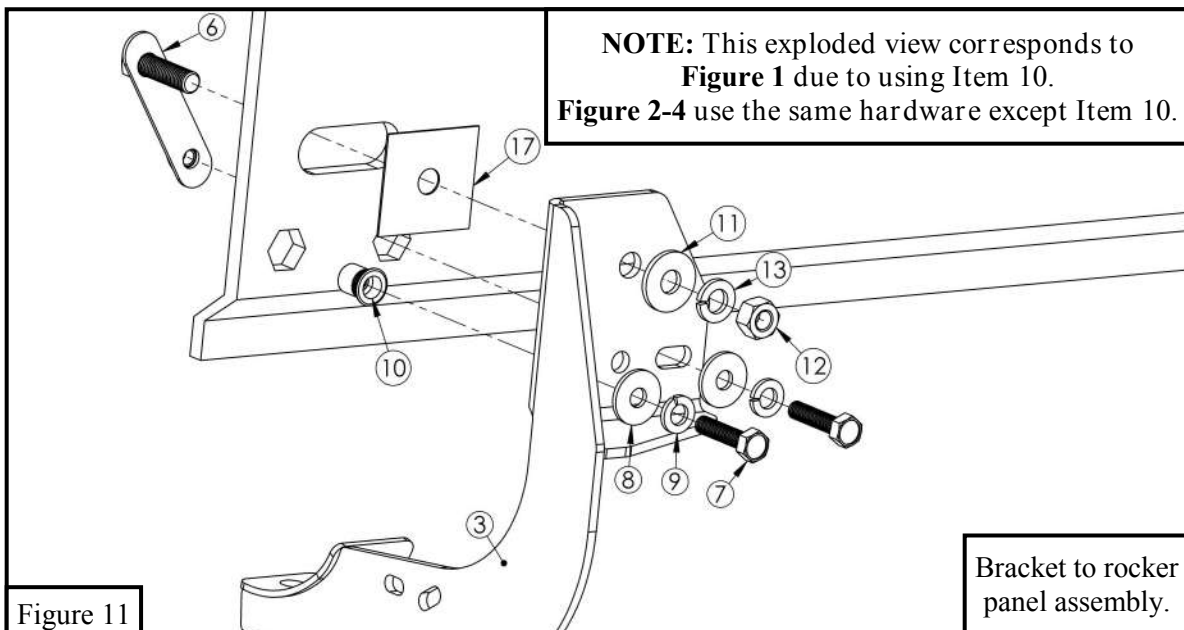

Figure 11

Bracket to rocker panel assembly.



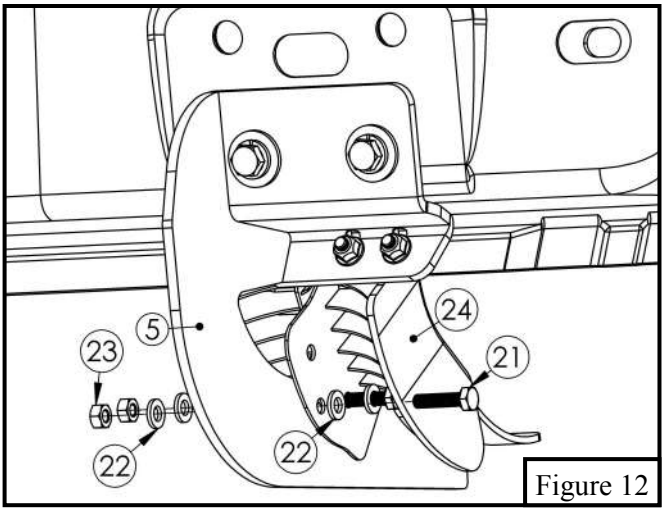

Figure 12

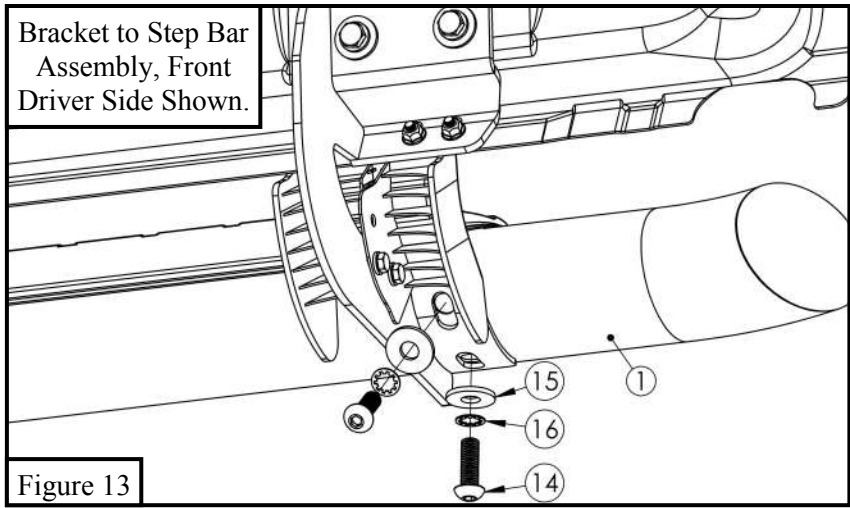

Figure 13

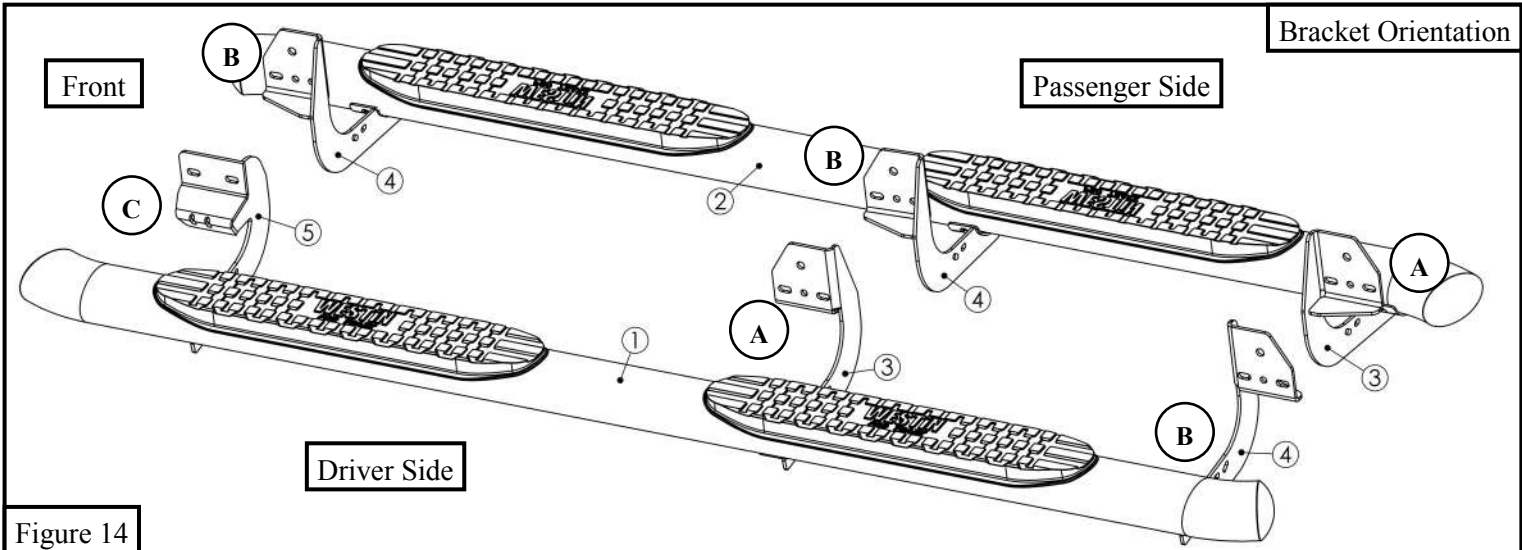

Figure 14



**Care Instructions**

- REGULAR WAXING IS RECOMMENDED. DO NOT USE ANY TYPE OF POLISH OR WAX THAT MAY CONTAIN ABRASIVES.
- STAINLESS STEEL PRODUCTS CAN BE CLEANED WITH MILD SOAP AND WATER. STAINLESS STEEL POLISH SHOULD BE USED TO POLISH SMALL SCRATCHES.
- GLOSS BLACK FINISHES SHOULD BE CLEANED WITH MILD SOAP AND WATER.



Westin Automotive Products, Inc.  
320 W. Covina Blvd  
San Dimas, Ca. 91773

Thank you for choosing Westin products  
for additional installation assistance please call  
Customer Service (800) 793-7846  
www.westinautomotive.com

# Westin

SIGNATURE OF QUALITY

AUTOMOTIVE PRODUCTS, INC.



## WARNING



Failure to follow these instructions could lead to death, personal injury, and / or property damage.

### FASTENERS:

All Westin supplied fasteners must be utilized and installed in accordance with the installation instructions and apply torque to the specifications as defined. **DOUBLE CHECK ALL FASTENERS BEFORE INITIAL USE, AND PERIODICALLY IN THE FUTURE TO ENSURE PROPER FUNCTION AND SAFETY.**

### DRILLING:

Most Westin products do not require drilling for installation. If drilling is defined as required, use caution when drilling a vehicle. **FAILURE TO REVIEW AN AREA TO BE DRILLED MAY RESULT IN PERSONAL INJURY AND/OR INJURY TO OTHERS AS WELL AS VEHICLE DAMAGE.**

### EYE PROTECTION:

**ALWAYS WEAR SAFETY GLASSES OR GOGGLES DURING THE INSTALLATION PROCESS TO AVOID PERSONAL INJURY.**

### MAXIMUM TOWING/CARRYING CAPACITY:

The Westin Receiver Hitches will have a visible tow rating label affixed directly on the product. User should never exceed the vehicle manufacturers maximum tow and weight rating regardless of the capacity of the hitch. **FAILURE TO FOLLOW THESE GUIDELINES WILL VOID THE WESTIN WARRANTY AND MAY RESULT IN PERSONAL INJURY AND/OR INJURY TO OTHERS AS WELL AS VEHICLE DAMAGE.**

**Westin**  
SIGNATURE OF QUALITY

Westin Automotive Products, Inc.  
320 W. Covina Blvd  
San Dimas, Ca. 91773