

IARMOR EDGE™

PART#: IA-N296

BEFORE INSTALLATION

REMOVE CONTENTS FROM BOX. VERIFY ALL PARTS ARE PRESENT. READ INSTRUCTIONS CAREFULLY BEFORE STARTING INSTALLATION. ASSISTANCE IS RECOMMENDED. THANK YOU FOR CHOOSING OUR PRODUCT!

***DRILLING NOT REQUIRED**

***TRIMMING NOT REQUIRED**

Torque Value

Fastener Size	Tightening Torque (ft-lbs)	Required
6mm	6-7	√
8mm	16-18	√
10mm	31-32	X
12mm	56-58	X
14mm	92-94	X

PART LIST

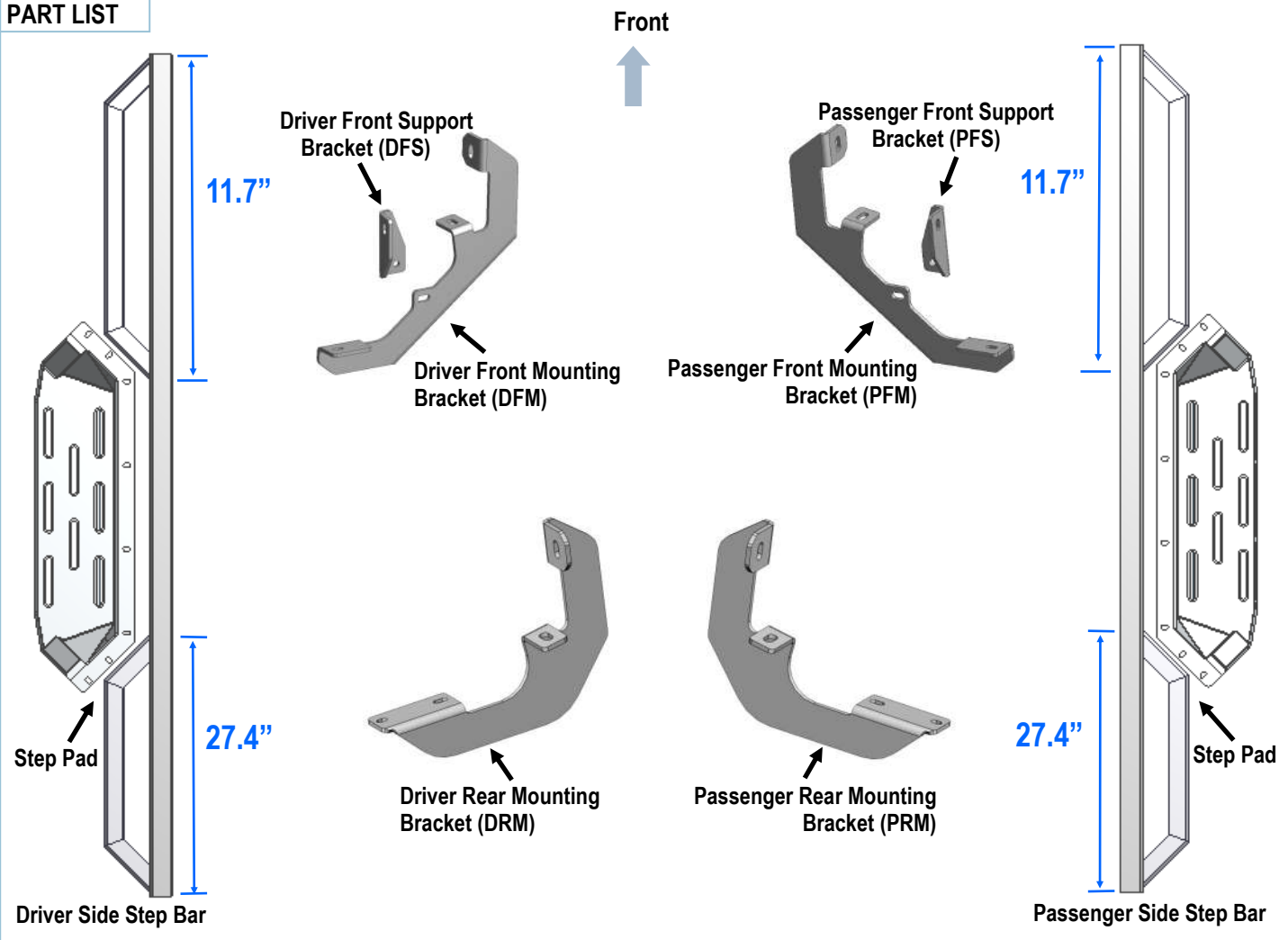

Customer Support: info@iarmorauto.com

iArmor®



The instruction here is for your reference only. We strongly recommend the professional installer for best result. We are not responsible for any damage caused by the installation.

STEP 1

Install the Step Pads onto the step bars with (16) M6x1-20 T-Bolts, (16) M6 Flat Washers and (16) M6X1 Nylon Lock Nuts.

IMPORTANT: Don't hit the step pad by any metal hammer within step pad installation, or the step pad will be damaged.

(8) M6X1-20 T-Bolts
(8) M6 Flat Washers
(8) M6 Nylon Lock Nuts

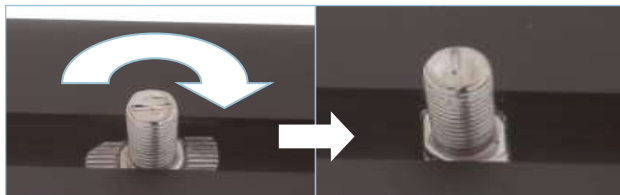

Note: Rotate 90° after inserting the T-Bolts into the Channel!!!

STEP 2

Start the installation under the Driver side of the vehicle. Locate the plastic plugs along the bottom edge of the body. Mounting Brackets will attach to the threaded mounting holes at the front and rear of the cab. Remove the plastic plugs from the Driver Side Front Mounting Location. Directly above each threaded insert is a top mounting location with a threaded insert on the side of the body panel, (**Fig 1**). Hold a bracket up in place to help determine the correct mounting holes to use along the body.

NOTE: Thread (1) M8X1.25-30 Hex Bolt into the threaded inserts to clear paint as required.

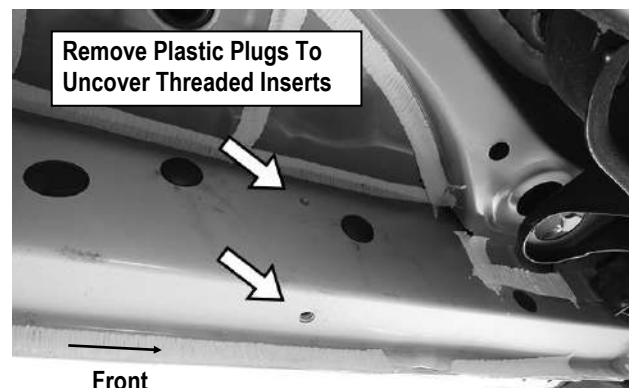

(Fig 1) Driver Side Front Mounting Location

iArmor®

STEP 3

Assemble the Driver Front Mounting Bracket (DFM) and Driver Front Support Bracket (DFS) with (1) M8X1.25-30 Hex Bolt, (2) M8 Flat Washers and (1) M8X1.25 Nylon Lock Nut, (Fig 2). Do not fully tighten hardware at this time.

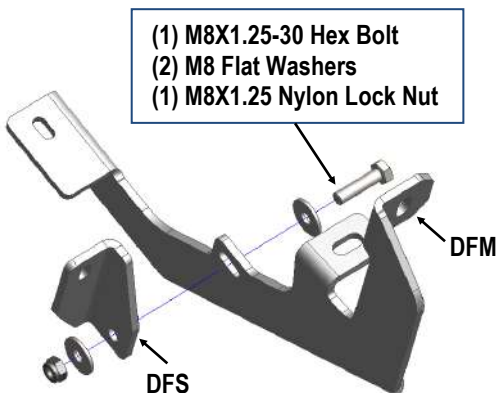

(Fig 2) Driver Front Mounting Bracket Assembly

STEP 4

Attach the assembled Driver Front Mounting Bracket to the factory threaded holes with (2) M8X1.25-30 Hex Bolts, (2) M8 Lock Washers and (2) M8 Flat Washers, (Fig 3). Do not fully tighten hardware.

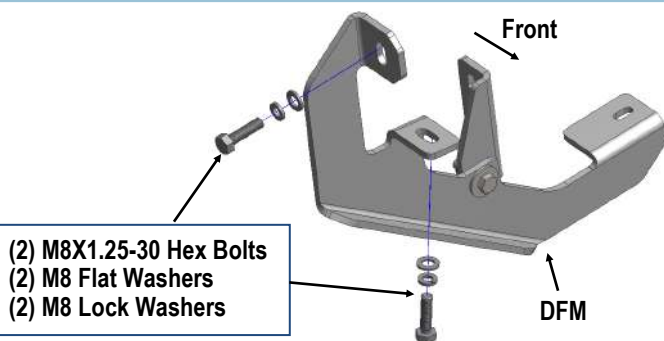

(Fig 3) Driver Front Mounting Bracket Installed

STEP 5

Move to the Driver Side Rear Mounting location, (Fig 4). Repeat Step 4 to attach (1) Driver Rear Mounting Bracket (DRM) to the rocker panel, (Fig 5). Do not fully tighten hardware at this time.

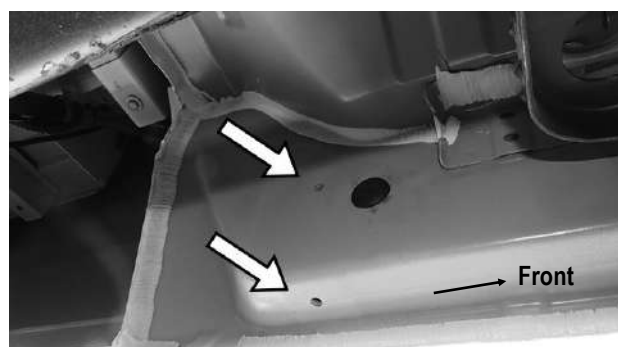

(Fig 4) Driver Side Rear Mounting Location

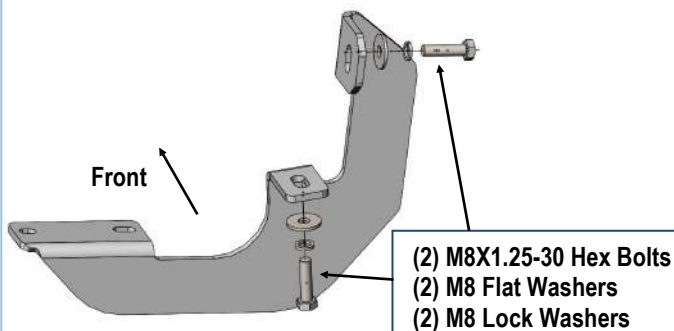

(Fig 5) Driver Rear Mounting Bracket Installed

STEP 6

Once all (2) Brackets have been installed, attach the assembled Driver Side Step Bar to the Mounting Brackets with (2) M6X1-20 T-Bolts, (2) M6X1-20 Square Head Bolts, (4) M6 Large Flat Washers and (4) M6X1 Nylon Lock Nuts, (Fig 6). Do not fully tighten hardware at this time.

iArmor®

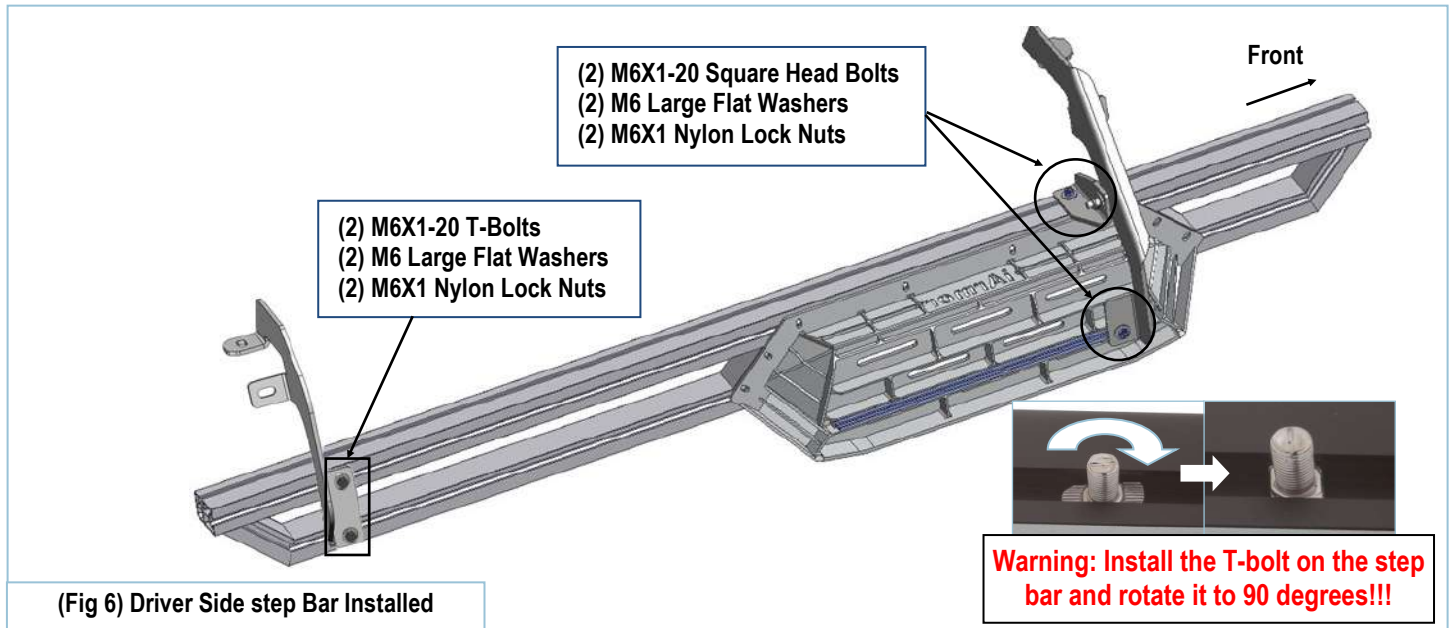

STEP 7

Properly level and adjust the Step Bar and fully tighten all hardware.

Move to the Passenger side of the vehicle. Repeat **Steps 2-6** for the Passenger Side Step Bar installation.

Attention

Do periodic inspections to the installation to make sure that all hardware is secure and tight.

In order to protect your bars/boards, please use only mild soap/non-abrasive products for cleaning.