

iArmor®

IARMOR EDGE™

PART#: IA-W296

BEFORE INSTALLATION

REMOVE CONTENTS FROM BOX. VERIFY ALL PARTS ARE PRESENT. READ INSTRUCTIONS CAREFULLY BEFORE STARTING INSTALLATION. ASSISTANCE IS RECOMMENDED. THANK YOU FOR CHOOSING OUR PRODUCT!

*ROCKER PANEL MOUNT

*DRILLING NOT REQUIRED

Fastener Size	Tightening Torque (ft-lbs)	Required
6mm	6-7	X
8mm	16-18	√
10mm	31-32	√
12mm	56-58	X
14mm	92-94	X

Driver

Front

Passenger

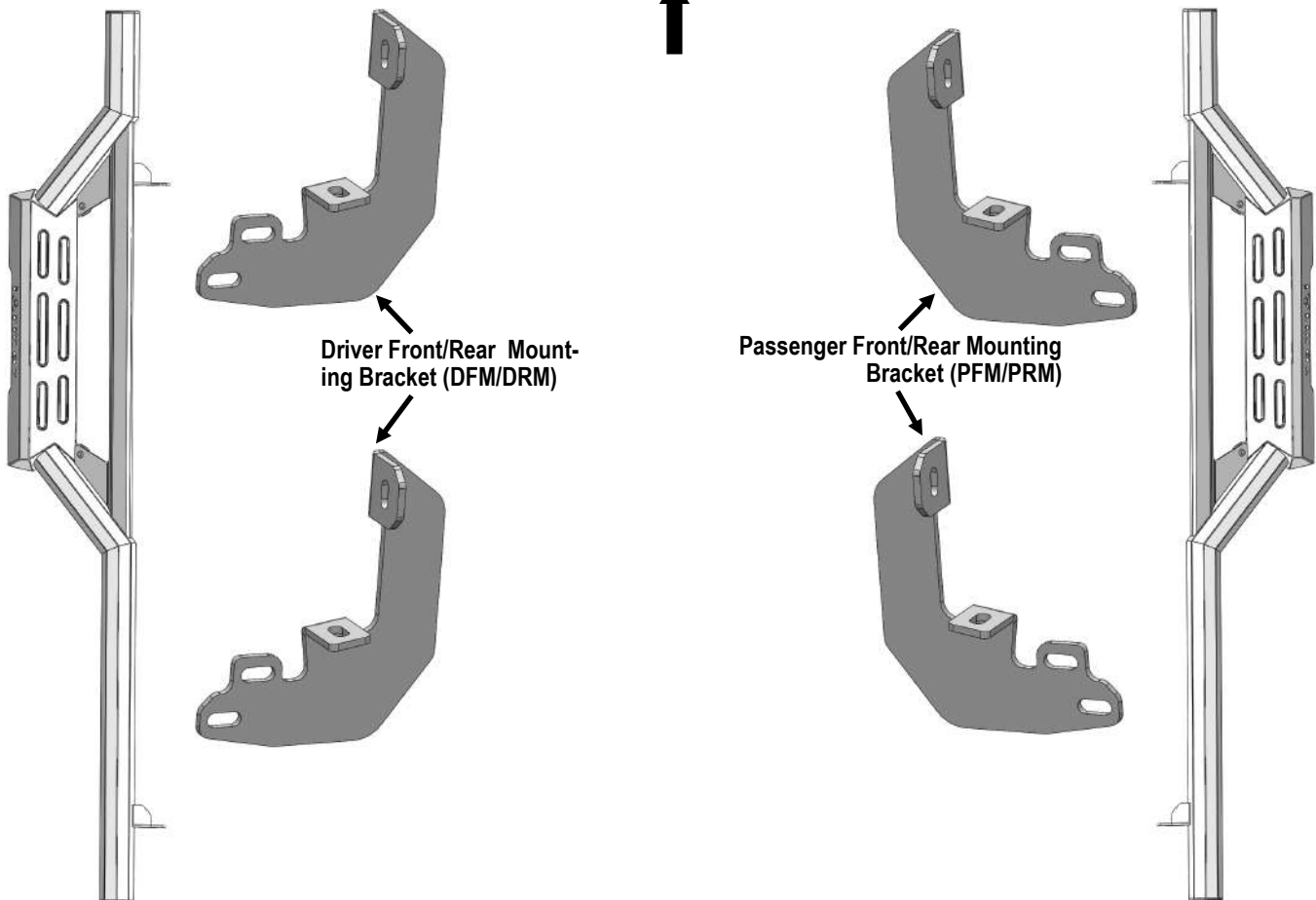

iArmor[®]

Hardware Package (For Brackets & Step Bars Installation)

Item	QTY	Description	Item	QTY	Description
1#	8	M8X1.25-30 Hex Bolts	4#	8	M10X1.5-25 Hex Bolts
2#	8	M8 Large Flat Washers	5#	16	M10 Flat Washers
3#	8	M8 Lock Washers	6#	8	M10X1.5 Nylon Lock Nuts

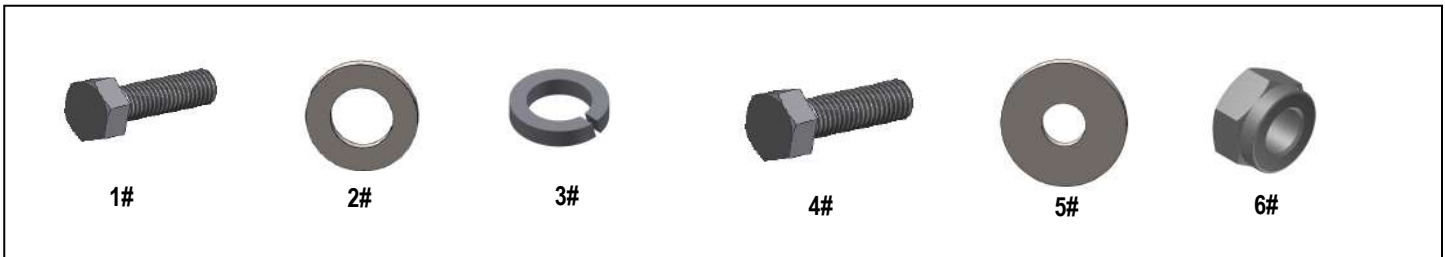

iArmor®

The instruction here is for your reference only. We strongly recommend the professional installer for best result. We are not responsible for any damage caused by the installation.

STEP 1

Start the installation under the Driver side of the vehicle. Locate the Driver Side Front Mounting Location on the body panel (**Fig 1**). Remove the plastic plugs from the threaded inserts if equipped. (**Fig 1**). The Driver Front Mounting Bracket will be attached to the threaded mounting holes on body panel.

NOTE:

*It will be helpful for identifying the mounting holes to hold up a mounting bracket in place.

*Thread (1) M8X1.25-30 Hex Bolt into the threaded inserts to clear paint as required.

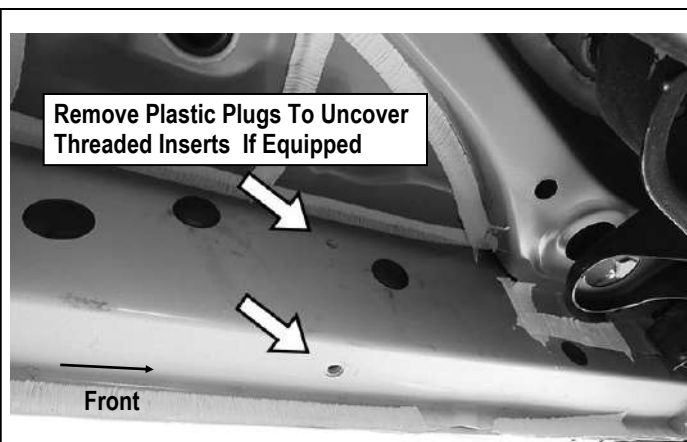

(Fig 1) Driver Side Front Mounting Location

STEP 2

Select (1) Driver Front Mounting Bracket (**DFM/DRM**). Attach the Driver Front Mounting Bracket to the factory threaded holes with (2) M8X1.25-30 Hex Bolts, (2) M8 Lock Washers and (2) M8 Large Flat Washers, (**Fig 3**). Do not fully tighten hardware.

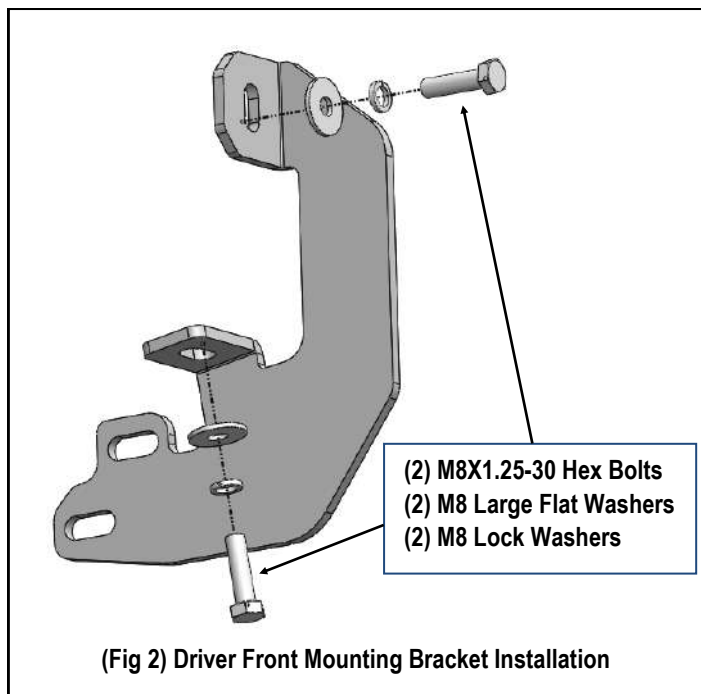

STEP 3

Move to the Driver Side Rear Mounting location, (**Fig 3**). Repeat **Step 2** to attach Driver Rear Mounting Bracket (**DFM/DRM**) to the rocker panel. Do not fully tighten hardware at this time.



(Fig 3) Driver Side Rear Mounting Location

iArmor®

Once all (2) Brackets have been installed, attach the Driver Side Bar to the assembled Bar Brackets with (4) M10X1.5-25 Hex Bolts, (8) M10 Flat Washers and (4) M10X1.5 Nylon Lock Nuts, (Fig 4). Do not fully tighten hardware at this time.

Properly level and adjust the Step Bar and fully tighten all hardware.

STEP 4

Move to the other side of the vehicle. Repeat **Steps 1-3** to install the other side step bar.

Attention

Do periodic inspections to the installation to make sure that all hardware is secure and tight.

In order to protect your bars/boards, please use mild soap/non-abrasive products for cleaning only.

(Fig 4) Driver Side Step Bar Installation

