

iArmor®

IARMOR EDGE™

PART#: IA-W071

BEFORE INSTALLATION

REMOVE CONTENTS FROM BOX. VERIFY ALL PARTS ARE PRESENT. READ INSTRUCTIONS CAREFULLY BEFORE STARTING INSTALLATION. ASSISTANCE IS RECOMMENDED. THANK YOU FOR CHOOSING OUR PRODUCT!

*ROCKER PANEL MOUNT

*DRILLING NOT REQUIRED/TRIMMING MAYBE REQUIRED

Torque Value

Fastener Size	Tightening Torque (ft-lbs)	Required
6mm	6-7	X
8mm	16-18	√
10mm	31-32	√
12mm	56-58	X
14mm	92-94	X

PART LIST

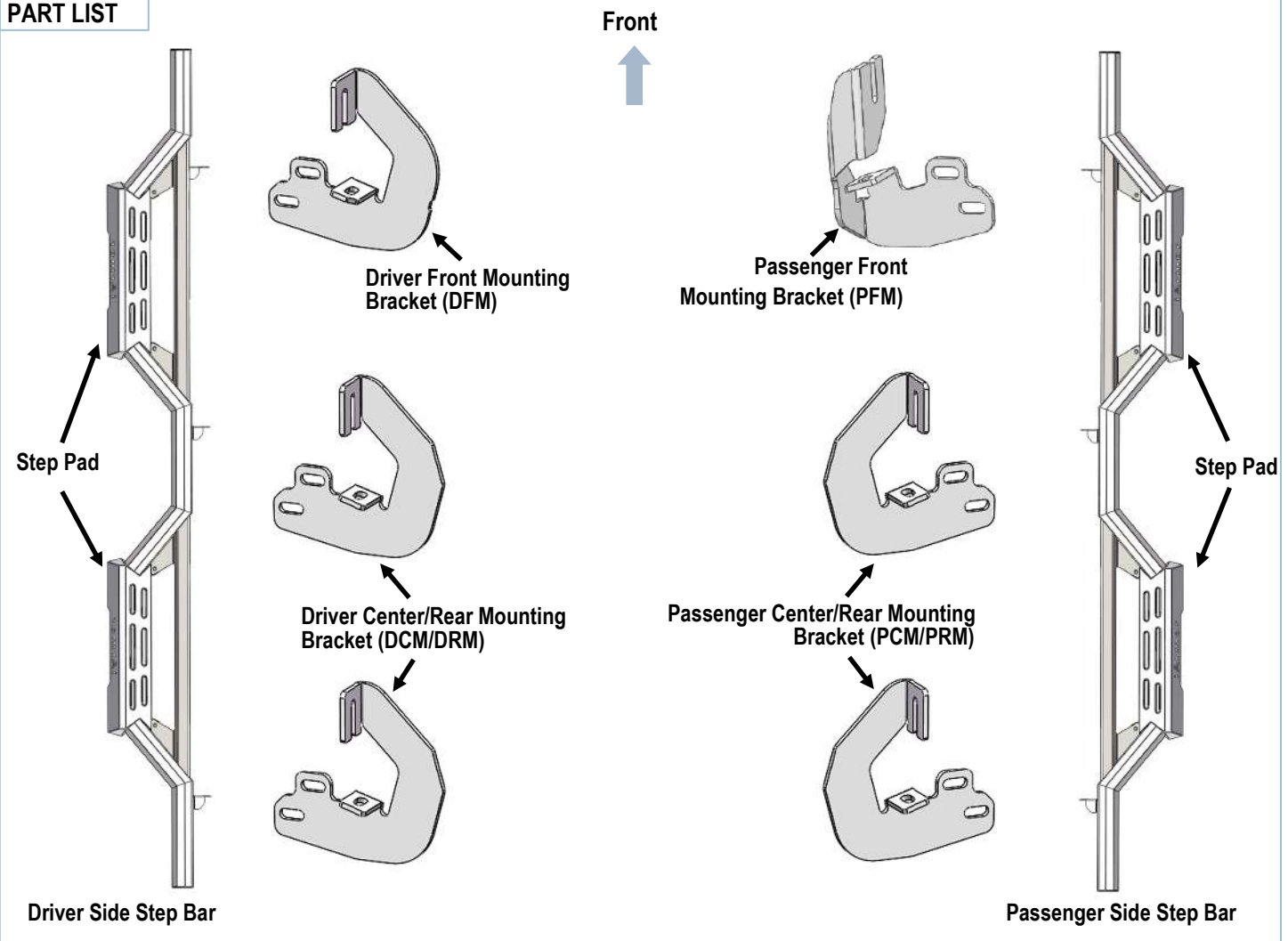

Customer Support: info@iarmorauto.com

iArmor[®]

Hardware Package (For Brackets & Step Bars Installation)

Item	QTY	Description	Item	QTY	Description
1#	12	M8X1.25-25 Hex Bolts	5#	12	M10X1.5-25 Hex Bolts
2#	12	M8 Flat Washers	6#	24	M10 Flat Washers
3#	12	M8 Lock Washers	7#	12	M10X1.5 Nylon Lock Nuts
4#	12	M8 Clip Nuts			



1#



2#



3#



4#



5#



6#



7#

iArmor®

The instruction here is for your reference only. We strongly recommend the professional installer for best result. We are not responsible for any damage caused by the installation.

STEP 1

Start the installation under the Driver/Left side of the vehicle. Locate the 5 tabs along the bottom edge of the body, (pinch weld). Mounting will use the 1st, 2nd and 5th tab locations (Fig 1). Directly above each tab is a top mounting location on the side of the body panel. Hold a Bracket up in place to help determine the mounting holes to use along the body.

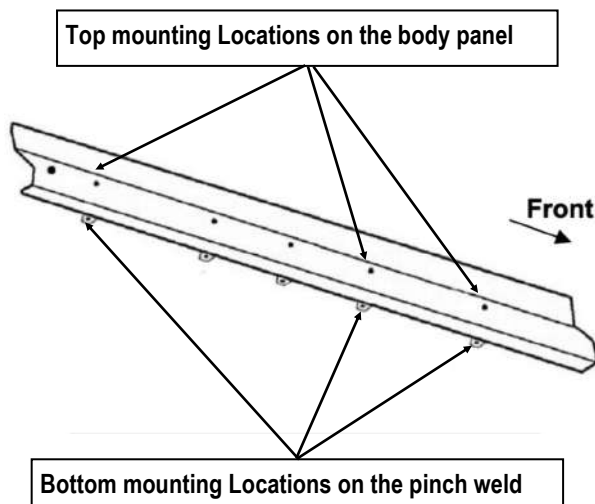

(Fig 1) Driver Side (3) Mounting Locations

STEP 2

Determine the correct procedure for your model year and each bracket location.

A. Bottom mounting location on the edge of the pinch weld.

*Flat tab on pinch weld with factory installed weld nut:

Thread M8 Hex Bolt into weld nut from the backside-down to clear paint from threads, (Fig 2).

*Flat tab on pinch weld with hole:

Select (1) M8 Clip Nut. Slide the M8 Clip Nut over the tab with the nut facing up behind the tab, (Fig 3). Line up threaded nut with hole in tab.

B. Top mounting location on the back side of the body panel.

*Models with factory installed threaded insert in body panel:

Thread M8 Hex Bolt into threaded insert to clear paint as required, (Figs 2&4).

*Large and small hole in side of body panel:

Remove the rubber plug from the larger hole. Select (1) M8 Clip Nut. Slide the M8 Clip Nut into the larger hole. Line up the threaded nut with the smaller hole, (Figs 3&5).

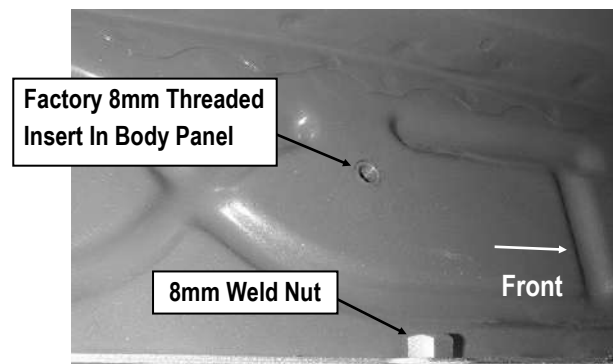

(Fig 2) Driver Side Front Mounting Location

iArmor[®]

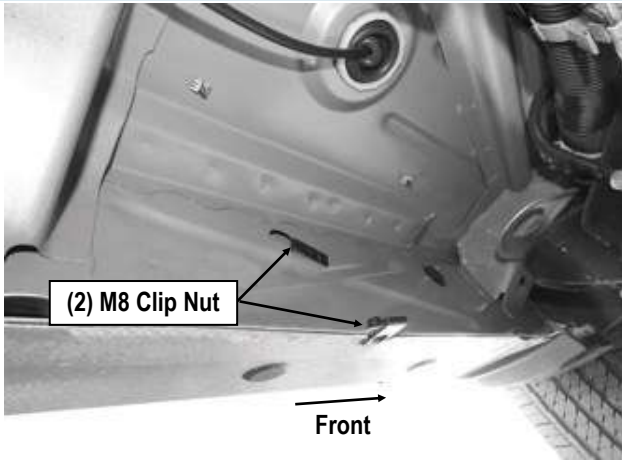

(Fig 3) Driver Side Front Mounting Location

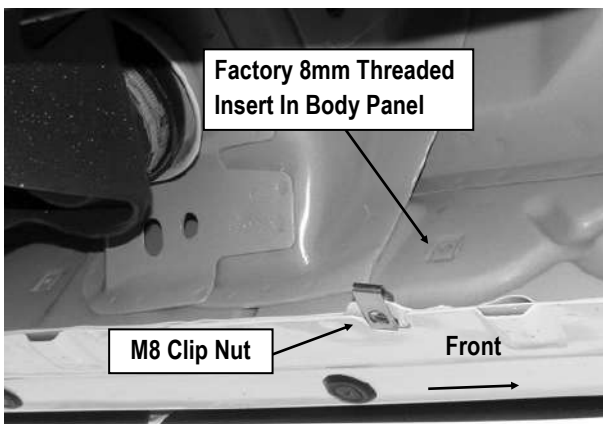

(Fig 4) Driver Side 2nd Mounting Location

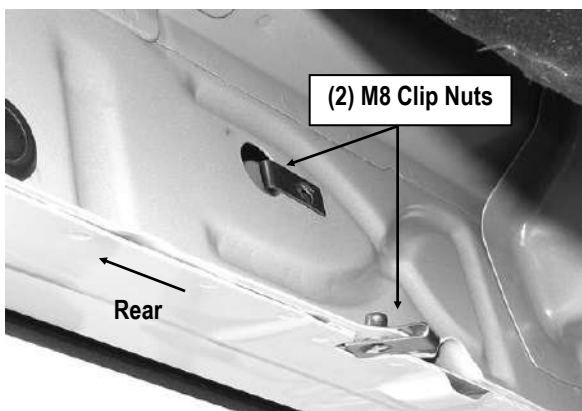

(Fig 5) Driver Side Rear Mounting Location

STEP 3

Start from the driver front mounting location. Attach the Driver Front Mounting Bracket (DFM) to the Clip Nuts and/or the factory threaded holes with (2) M8X1.25-25 Hex Bolts, (2) M8 Lock Washers and (2) M8 Flat Washers, (Fig 6). Do not fully tighten hardware.

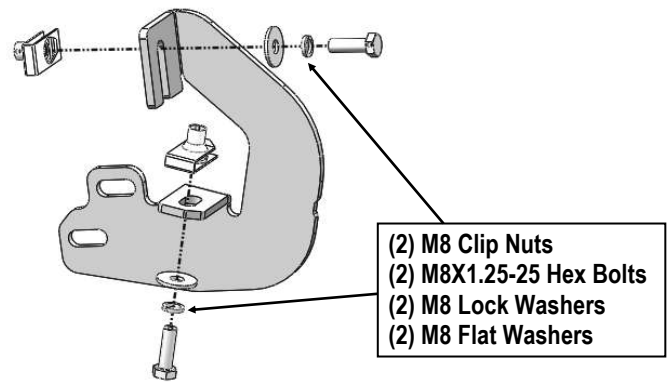

(Fig 6) Driver Front Mounting Bracket Installed

STEP 4

Repeat **Steps 1-3** to attach the (2) remaining driver side Mounting Brackets to the 2nd and rear mounting locations, (Figs 4 & 5).

STEP 5

Once all (3) Brackets have been installed, attach the Driver Side Step Bar to the Mounting Brackets using (6) M10X1.5-25 Hex Bolts, (12) M10 Flat Washers and (6) M10X1.5 Nylon Lock Nuts, (Fig 7). Do not fully tighten hardware at this time.

Level and adjust the Step Bar and fully tighten all hardware.

iArmor®

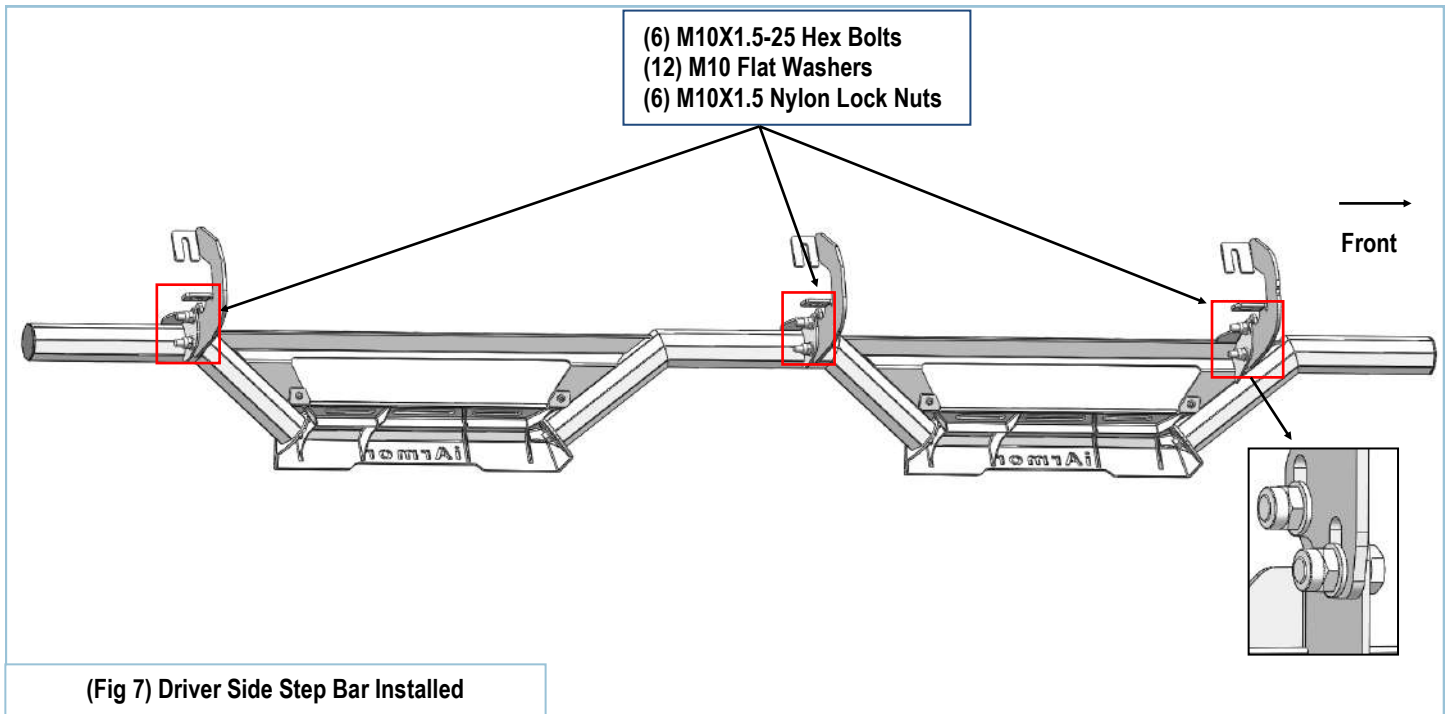

STEP 6

Move to the passenger side of the vehicle. On the passenger side, determine if the vehicle is equipped with a plastic diesel exhaust fluid (DEF) tank, (Fig 8 & 9).

(1) Models without DEF tank skip to Step 7.

(2) Models with DEF tank:

The tank sits close to the side of the body. With specialized tools, the Passenger Front Mounting Bracket can be installed but room is very limited. Determine model year of vehicle before proceeding.

A) Up to 2016 models:

It may be easier to drop the tank down to access the inner side of the body panel for the Passenger Side Front Mounting Bracket installation. Tank will not need to be removed, only dropped down for access to mounting location. **IMPORTANT:** If tank is full, it will be very heavy and assistance is highly recommended to avoid injury or damage to the vehicle or the tank. It is recommended that installation is performed when the DEF tank is low on fluid before dropping the tank.

- On models with plastic lower tray under the tank, remove the (3) hex bolts attaching the tray to the frame, (Fig 8), and remove the tray.
 - Release the tank filler hose. Release the plug for the sending unit on the top of the tank.
 - Support the tank with a floor jack. Place a smooth flat surface, (wooden block for example), between the floor jack and the tank to avoid damaging the plastic tank. Do not push up on the tank; only support the weight of the tank with the jack.
 - Remove the (2) bolts securing the tank straps to the vehicle, (Fig 9). Tilt the straps to release from the brackets. Slowly lower the tank until the top of the tank is almost visible. Use blocks or stands to support the tank while installing the Passenger Front Mounting Bracket.
 - Proceed to **Step 7**.
- B) 2017-Up models:**
- Remove the (4) hex bolts attaching plastic cover to DEF tank, (Fig 10) and remove plastic cover, (Fig 11). **NOTE:** On 2017 2500/3500 models, only remove plastic cover from DEF tank. Do not lower DEF tank and proceed to **Step 7**.

iArmor®

Remove (3) Hex Bolts
To Remove Cover

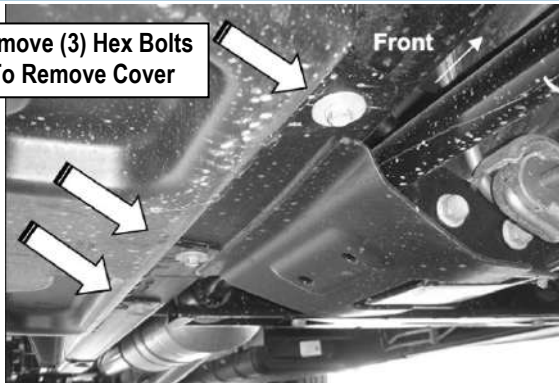

(Fig 8) 07-16 Passenger Side Front Pictured with DEF Tank Cover

Remove (2) factory bolts to
remove tank straps

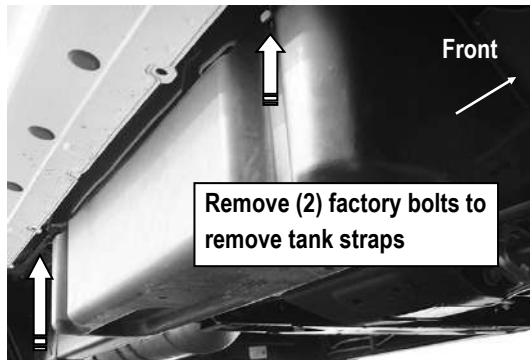

(Fig 9) 07-16 Passenger Side DEF Tank and Cover

Remove (4) hex bolts
to remove plastic cover

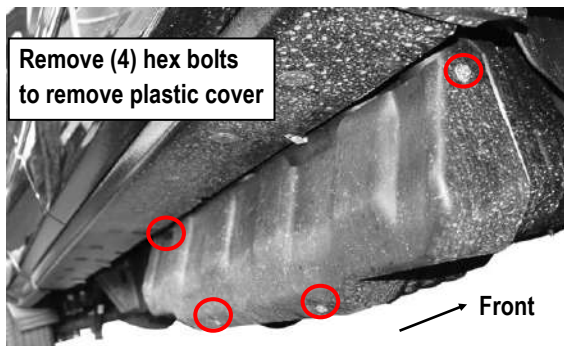

(Fig 10) 2017-Up Passenger Side Pictured w/DEF tank cover

Front

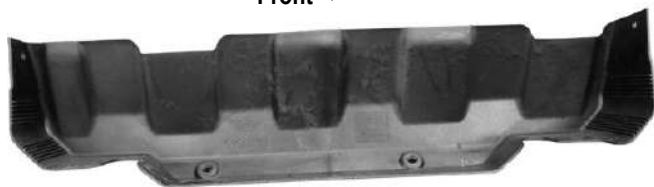

(Fig 11) 2017 Passenger Side DEF Cover Removed

STEP 7

Locate the first tab on the edge of the pinch weld, attach the Passenger Front Mounting Bracket (PFM) to the pinch weld and top body panel (Fig 12 & 13):

- Models with flat tab and hole:** see Fig 12. Leave loose at this time.
- Models with weld-nut:** see Fig 13. Leave loose at this time.

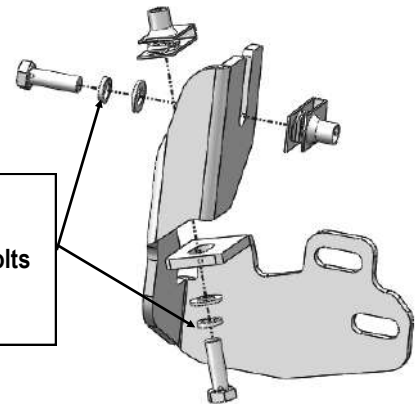

Models With Hole :
(2) M8 Clip Nuts
(2) M8x1.25-25 Hex Bolts
(2) M8 Lock Washers
(2) M8 Flat Washers

(Fig 12) Passenger Front Mounting Bracket Installed

M8 Clip Nut
M8x1.25-25 Hex Bolt
M8 Lock Washer
M8 Flat Washer

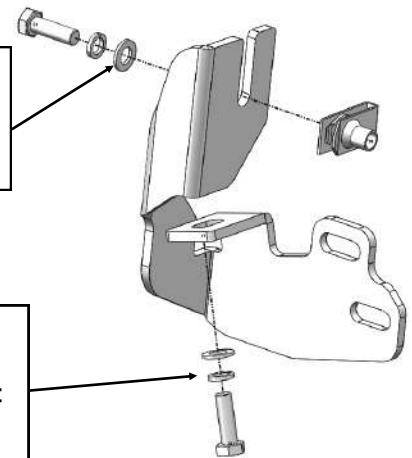

Models With Weld
Nut On Pinch Weld:
M8x1.25-25 Hex Bolt
M8 Lock Washer
M8 Flat Washer

(Fig 13) Passenger Front Mounting Bracket Installed (Weld Nut If Equipped-Also See Fig 2)

iArmor®

STEP 8

Repeat **Steps 2-5** for the (2) remaining passenger side Bracket installations.

2017-Up 2500/3500 DEF tank models: Locate the 2nd tab bracket location along the bottom edge of the body, (pinch weld), (**Fig 14**). Hold the DEF cover in place and mark the location onto the cover, (**Fig 15**). Use a sharp knife or hacksaw blade to carefully cut a slot in the plastic cover to clear the 2nd Bracket, (**Fig 16**). Remove as little plastic as possible.

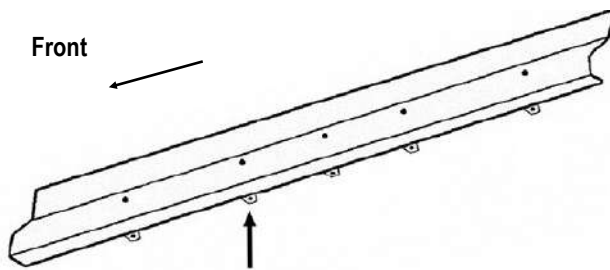

(Fig 14) Passenger Side 2nd Bracket Location from Back of Body Panel

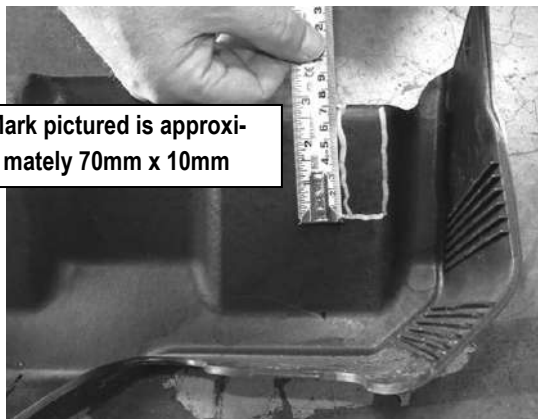

(Fig 15) 2017-Up Passenger Side DEF Cover Marked for Trimming

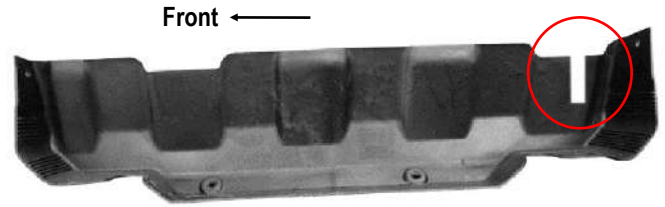

(Fig 16) 2017-Up Passenger Side DEF Cut for Example Only

STEP 9

Repeat **Step 5** to install the Passenger Side Step Bar.

STEP 10

Once the Step Bar has been installed and all hardware fully tightened, reinstall the DEF tank and cover, if equipped, as described in **Step 6**.

Installation completed.

Attention

Do periodic inspections to the installation to make sure that all hardware is secure and tight.

In order to protect your bars/boards, please use mild soap/non-abrasive products for cleaning only.