

# iArmor®

## IARMOR EDGE™

PART#: IA-W208

### BEFORE INSTALLATION

REMOVE CONTENTS FROM BOX. VERIFY ALL PARTS ARE PRESENT. READ INSTRUCTIONS CAREFULLY BEFORE STARTING INSTALLATION. ASSISTANCE IS RECOMMENDED. THANK YOU FOR CHOOSING OUR PRODUCT!

\*ROCKER PANEL MOUNT

\*DRILLING MAYBE REQUIRED

Fastener Size	Tightening Torque (ft-lbs)	Required
6mm	6-7	√
8mm	16-18	√
10mm	31-32	√
12mm	56-58	X
14mm	92-94	X

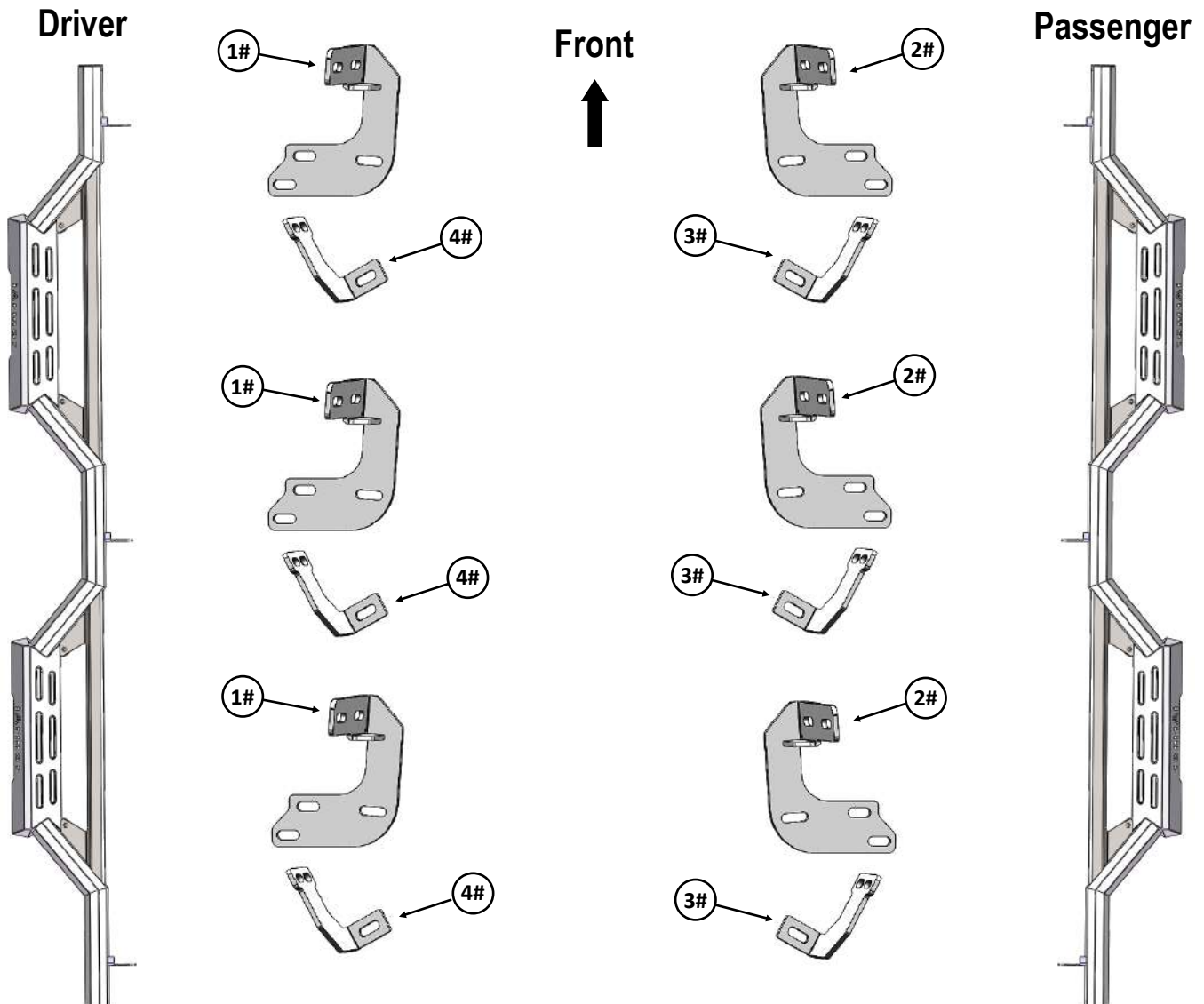

Customer Support: [info@iarmorauto.com](mailto:info@iarmorauto.com)

# iArmor<sup>®</sup>

Hardware Package A (For Brackets & Step Bars Installation)					
Item	QTY	Description	Item	QTY	Description
1#	3	Driver Side Mounting Brackets	10#	6	M8X1.25 Hex Nuts
2#	3	Passenger Side Mounting Brackets	11#	6	M8X1.25 Nylon Lock Nuts
3#	3	Passenger Side Support Brackets	12#	12	M6X1-25 Hex Bolts
4#	3	Driver Side Support Brackets	13#	24	M6 Large Flat Washers
5#	6	M8 Bolt/Nut Plates	14#	12	M6X1 Nylon Lock Nuts
6#	6	M8 Plastic Washers	15#	12	M10X1.5-25 Hex Bolts
7#	18	M8X1.25-30 Hex Bolts	16#	24	M10 Flat Washers
8#	24	M8 Large Flat Washers	17#	12	M10X1.5 Nylon Lock Nuts
9#	12	M8 Lock Washers			



# iArmor®

The instruction here is for your reference only. We strongly recommend the professional installer for best result. We are not responsible for any damage caused by the installation.

## STEP 1

Start installing from the passenger side front mounting location of the vehicle, (Fig 1). Remove the sealing tapes covering the oval hole and the hex holes on the body panel, if equipped. (Fig 1).

**Note:** All (3) Mounting Brackets and (3) Support Brackets for Passenger Side are universal. All (3) Mounting Brackets and (3) Support Brackets for Driver Side are universal.

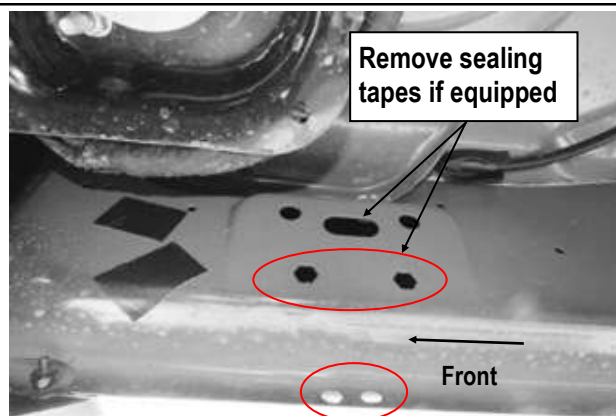

(Fig 1) Passenger Side Front Mounting Location (No factory holes on pinch weld on some trims)

## STEP 2

Determine the correct procedure to attach (1) Passenger Front Mounting Bracket for your model/year:

### **Models without factory threaded inserts on body panel:**

- Partially thread (1) M8X1.25-30 Hex Bolt into the welded nut on (1) M8 Bolt/Nut Plate (Fig 2). Thread the hex bolt in until it is flush with the welded nut, (Fig 3). Use the hex bolt as a handle and insert the Bolt/Nut Plate into the oval hole, feed the threaded bolt on the plate through one of the hex holes, (Fig 4). Thread (1) M8 Plastic Washer onto the threaded end and down tight against the body panel, (Fig 5). **NOTE:** The Plastic Washer is designed to keep

the Bolt Plate from falling into the body panel within bracket installation.

- Attach (1) Passenger Side Mounting Bracket to the threaded end of the installed M8 Bolt/Nut Plate with (1) M8 Large Flat Washer, (1) M8 Lock Washer and (1) M8X1.25 Hex Nut, (Fig 6).
- Remove the M8X1.25-30 Hex Bolt from the welded nut on the Bolt/Nut Plate. Rotate the Bolt/Nut Plate until the welded nut lines up with the other hole on the Mounting Bracket.
- Secure the Passenger Side Mounting Bracket to the welded nut on the M8 Bolt/Nut Plate with (1) M8x1.25-30 Hex Bolt, (1) M8 Lock Washer and (1) M8 Large Flat Washer (Fig 6). Do not fully tighten hardware at this time.



(Fig 2) M8 Bolt/Nut Plate (NOTE: M8 Bolt Plate is not required on models with threaded inserts)



(Fig 3) Thread M8X1.25-30 Hex Bolt into the welded nut on the plate

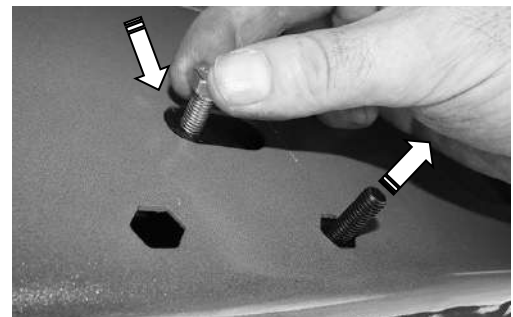

(Fig 4) Use the Hex Bolt as a handle. Insert the Bolt/Nut Plate into the oval hole and feed the threaded end out either factory hex hole.

**IMPORTANT:** Do not remove the Hex Bolt until the Plastic Washer is threaded onto the welded bolt (Fig 5).

# iArmor®



(Fig 5) Thread Plastic Washer onto Bolt Plate to hold Bolt Plate in position

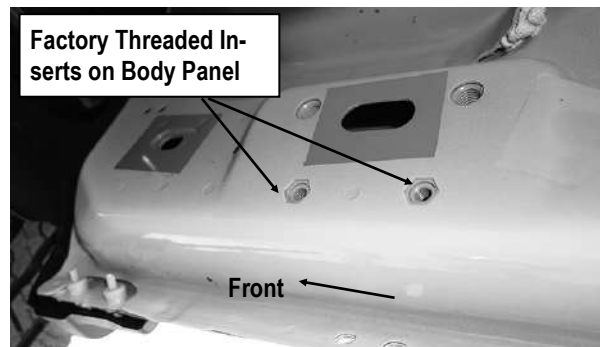

(Fig 7) Passenger Side Front Mounting Location (Example for models with factory threaded inserts)

- (1) M8X1.25-30 Hex Bolt
- (1) M8 Lock Washer
- (1) M8 Large Flat Washer

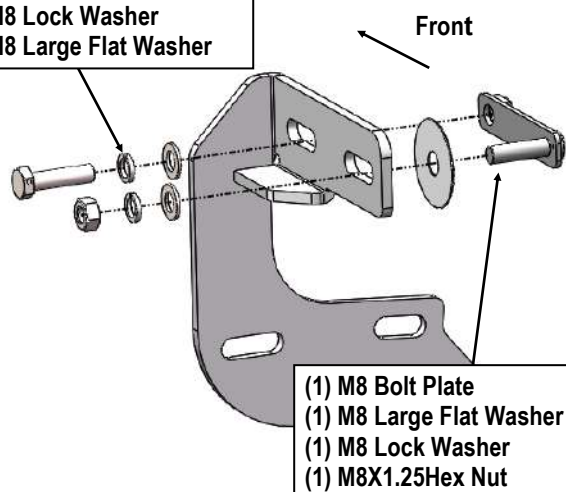

(Fig 6) Passenger Front Mounting Bracket installation (For models without factory threaded inserts on body panel)

- (2) M8X1.25-30 Hex Bolts
- (2) M8 Lock Washers
- (2) M8 Large Flat Washers (M8 Bolt/Nut Plate not required)

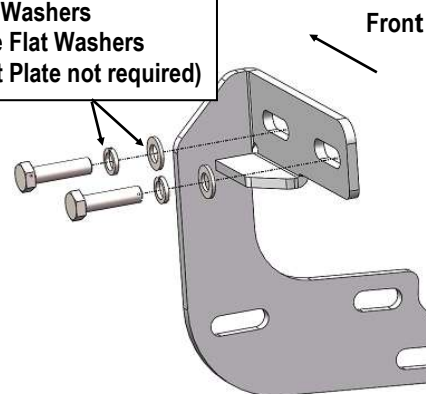

(Fig 8) Passenger Front Mounting Bracket installation (For models with factory threaded inserts on body panel)

## STEP 3

Attach (1) Passenger Side Support Bracket to the installed Passenger Side Mounting Bracket with (1) M8x1.25-30 Hex Bolt, (2) M8 Large Flat Washers and (1) M8X1.25 Nylon Lock Nut, (Fig 9).

Rotate and attach the support bracket to the back of the pinch weld. Line up the slots on the top of the Support Bracket with the (2) factory holes on the pinch weld. Secure the Bracket to the back of the pinch weld with (2) M6X1-25 Hex Bolts, (4) M6 Large Flat Washers and (2) M6X1 Nylon Lock Nuts, (Fig 10). Do not fully tighten hardware at this time.

### Models with factory threaded inserts on body panel (Fig 7):

Attach (1) Passenger Side Mounting Bracket to the threaded inserts on passenger side front mounting location with (2) M8x1.25-30 Hex Bolts, (2) M8 Lock Washers and (2) M8 Large Flat Washers, (Fig 8). Do not fully tighten hardware at this time.

# iArmor®

**IMPORTANT:** Some trims are without factory holes on pinch weld and **will require drilling** through the pinch weld to attach the Support Bracket. Do not drill on pinch weld at this moment, (Refer to STEP 6).

Passenger Side Support Bracket  
Passenger Side Mounting Bracket

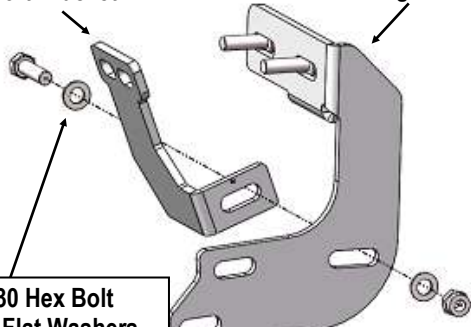

- (1) M8X1.25-30 Hex Bolt
- (2) M8 Large Flat Washers
- (1) M8X1.25 Nylon Lock Nut

(Fig 9) Attach the Support Bracket to the Mounting Bracket (On Passenger Side Front Mounting Location)

- (2) M6X1-25 Hex Bolts
- (4) M6 Large Flat Washers
- (2) M6X1 Nylon Lock Nuts

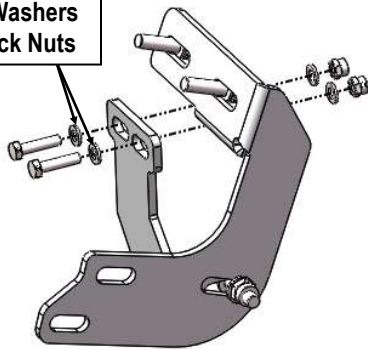

(Fig 10) Attach Passenger Front Support Bracket to back of pinch weld (Models with factory holes on pinch weld only)

## STEP 4

Move to the Passenger Side Center & Rear Mounting Locations, (Figs 11-12). Repeat **Steps 1-3** to install the Passenger side Center and Rear Mounting Brackets and Support Brackets. Do not fully tighten hardware at this time.

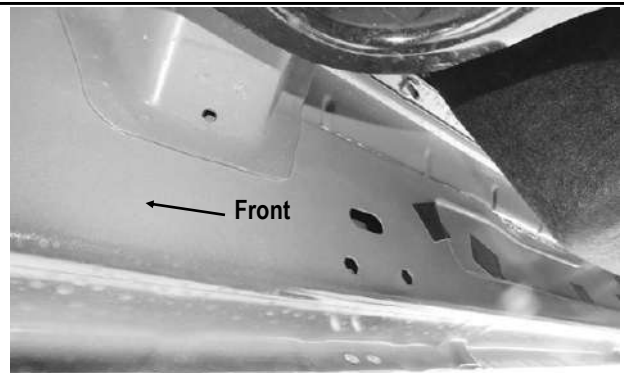

(Fig 11) Passenger Side Center Mounting Location

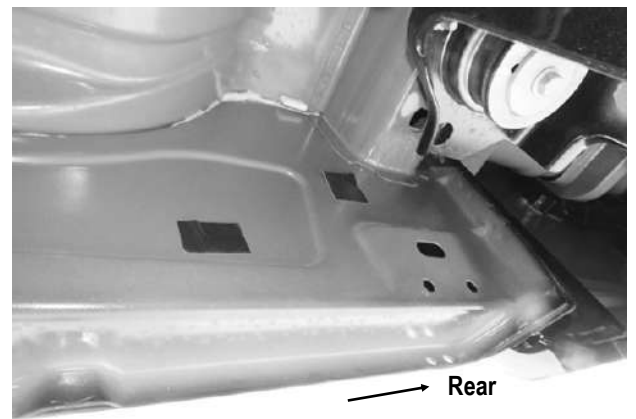

(Fig 12) Passenger Side Rear Mounting Location

## STEP 5

Once all (3) Passenger Side Mounting Brackets have been installed, attach the Passenger Side Step Bar to the Mounting Brackets with (6) M10X1.5-25 Hex Bolts, (12) M10 Flat Washers and (6) M10X1.5 Nylon Lock Nuts, (Fig 13). Do not fully tighten hardware at this time.

## STEP 6

Properly level and adjust the Step Bar and fully tighten all hardware.

**Models require drilling for installing Support Brackets:**

- a. Make sure the Step Bar is level to the vehicle. Adjust and tighten all mounting hardware.

# iArmor®

b. Line up the slots on the Support Brackets with the back of the pinch weld. Mark the location of the slots onto the pinch weld.

c. Drill (2) 1/4" holes through the pinch weld for each Support Bracket.

**IMPORTANT:** Do not drill too close to the bottom edge of the pinch weld. Adjust the Brackets as necessary to move the slots up the body panel away from the edge. Drill the holes toward the outside of the marked slots.

d. Attach each Support Bracket to the pinch weld with (2) M6X1-25 Hex Bolts, (4) M6 Large Flat Washers and (2) M6X1 Nylon Lock Nuts, (Fig 10). Check for level then fully tighten all hardware.

## STEP 7

Move to the other side of the vehicle. Repeat **Steps 1-6** to install the other side step bar.

### Attention

Do periodic inspections to the installation to make sure that all hardware is secure and tight.  
In order to protect your bars/boards, please use mild soap/non-abrasive products for cleaning only.

(Fig 13) Passenger Side Step Bar Installed

