

IARMOR EDGE™

PART#: IA-N175

BEFORE INSTALLATION

REMOVE CONTENTS FROM BOX. VERIFY ALL PARTS ARE PRESENT. READ INSTRUCTIONS CAREFULLY BEFORE STARTING INSTALLATION. ASSISTANCE IS RECOMMENDED. THANK YOU FOR CHOOSING OUR PRODUCT!

*DRILLING NOT REQUIRED

*TRIMMING NOT REQUIRED

Fastener Size	Tightening Torque (ft-lbs)	Required
6mm	6-7	√
8mm	16-18	√
10mm	31-32	X
12mm	56-58	X
14mm	92-94	X

Item	QTY	Description	Item	QTY	Description
1#	3	Driver Front / Passenger Center & Rear Mounting Brackets	5#	18	M8X1.25 Nylon Lock Nuts
2#	3	Passenger Front / Driver Center & Rear Mounting Brackets	6#	44	M6X1-20mm T-Bolts
3#	18	M8 Plastic Washers	7#	44	M6 Large Flat Washers
4#	18	M8 Flat Washers	8#	44	M6X1 Nylon Lock Nuts



iArmor[®]

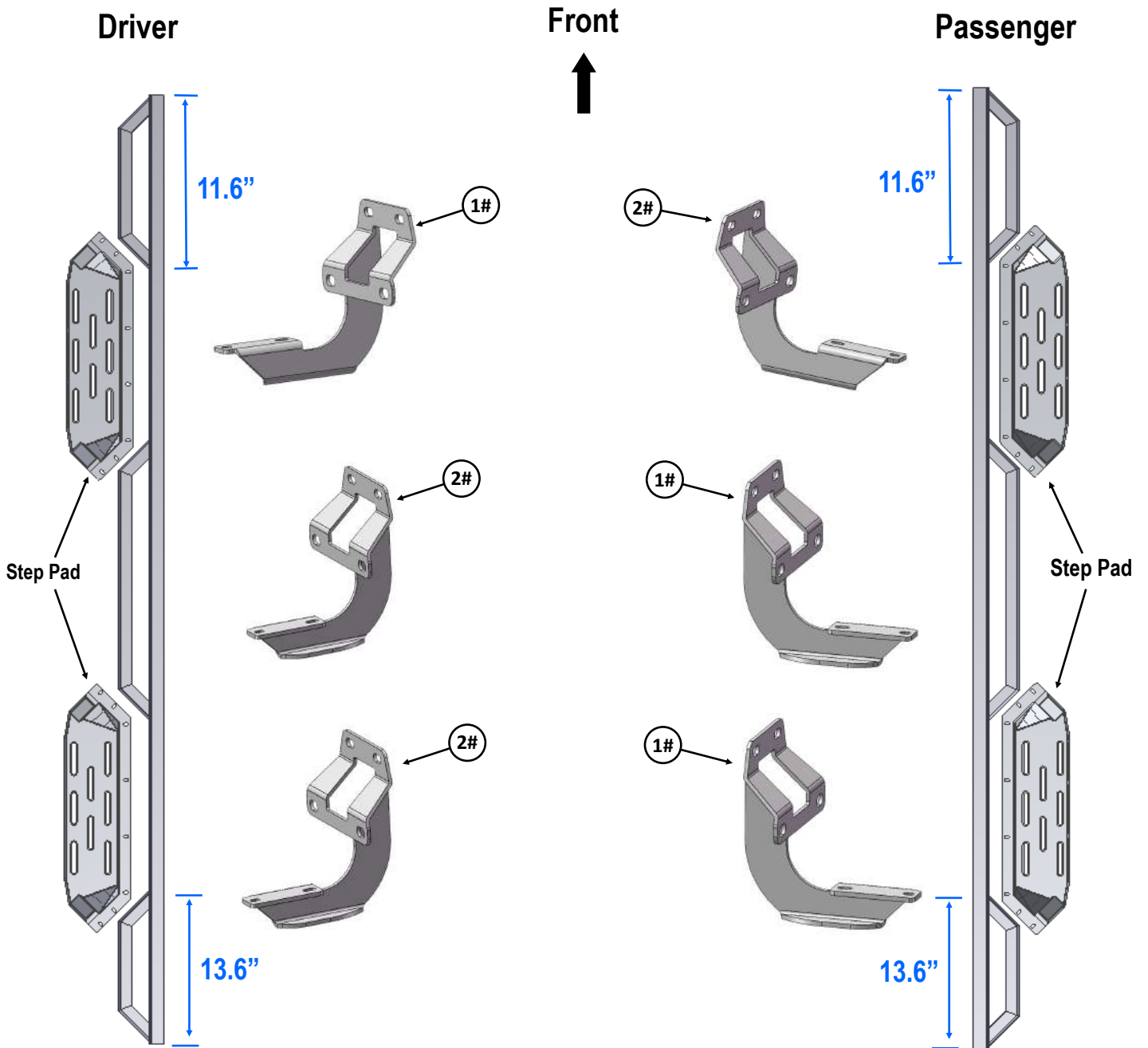

iArmor®

The instruction here is for your reference only. We strongly recommend the professional installer for best result. We are not responsible for any damage caused by the installation.

STEP 1

Install the Step Pads onto the step bars with (32) M6x1-20mm T-Bolts, (32) M6 Flat Washers and (32) M6x1 Nylon Lock Nuts.

IMPORTANT: Don't hit the step pad by any metal hammer within step pad installation, or the step pad will be damaged.

(8) M6X1-20mm T-Bolts
(8) M6 Flat Washers
(8) M6X1 Nylon Lock Nuts

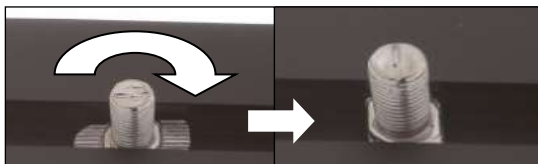

Note: Rotate 90° after inserting the T-Bolts into the Channel!!!

STEP 2

Start the installation from the driver/left side of the vehicle. Locate the Driver Side Mounting Locations along the inner side of the body panel, (Fig 1).

STEP 3

Slide (1) M8 Plastic Washer over each of the (3) factory mounting studs on the body panel, (Fig 2). **IMPORTANT:** The Plastic Washers are designed to prevent corrosion between the aluminum body panel and the steel mounting brackets. **Do not install the Brackets without the Plastic Washers.**

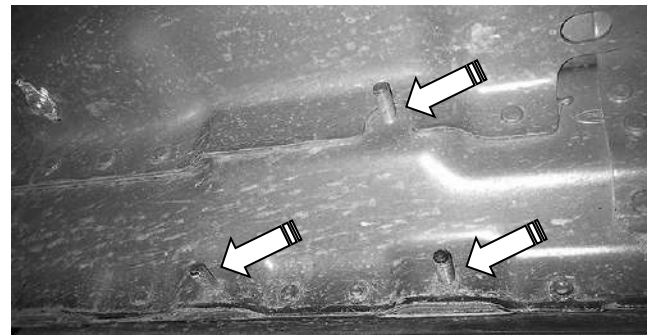

(Fig 1) Typical mounting location

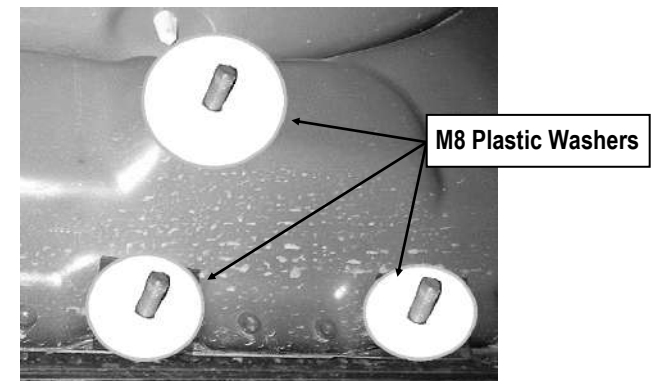

(Fig 2) Thread M8 Plastic Washers onto all mounting studs

STEP 4

Attach the Driver Front Mounting Bracket to the (3) factory studs with (3) M8 Flat Washers and (3) M8X1.25 Nylon Lock Nuts, (Fig 3). Do not fully tighten hardware at this time.

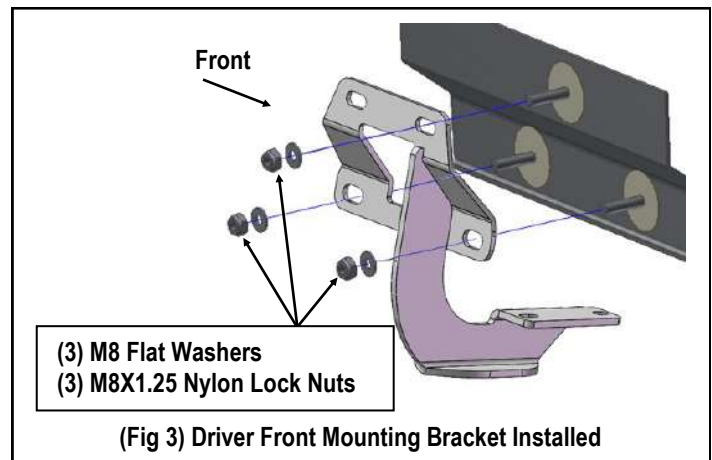

(3) M8 Flat Washers
(3) M8X1.25 Nylon Lock Nuts

(Fig 3) Driver Front Mounting Bracket Installed

iArmor®

STEP 5

Repeat **Step 4** to install the Driver center Mounting Bracket and Driver Rear Mounting Bracket, (**Fig 4**).

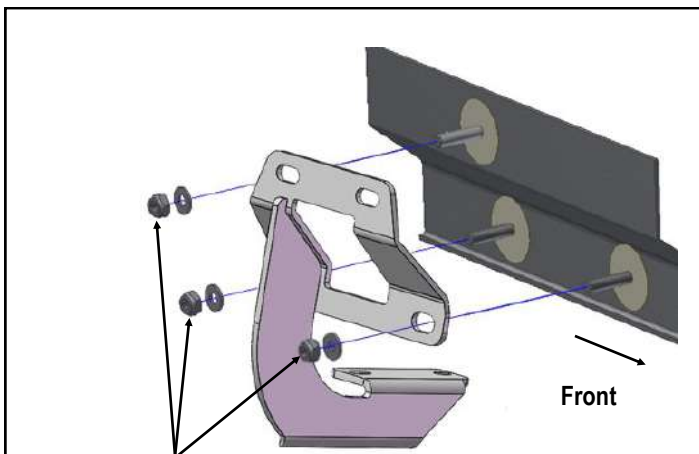

- (3) M8 Flat Washers
- (3) M8X1.25 Nylon Lock Nuts

(Fig 4) Driver Center/ Rear Mounting Bracket Installed

STEP 6

Once all (3) Brackets have been installed, attach the Assembled Driver Side Step Bar to the Mounting Brackets with (6) M6X1-20mm T-Bolts, (6) M6 Large Flat Washers & (6) M6X1 Nylon Lock Nuts, (**Fig 5**). Do not fully tighten hardware at this time.

STEP 7

Properly level and adjust the Step Bar and fully tighten all hardware.

STEP 8

Move to the other side of the vehicle. Repeat **Steps 1—7** for other side Step Bar installation.

Attention

Do periodic inspections to the installation to make sure that all hardware is secure and tight. In order to protect your bars/boards, please use only mild soap/non-abrasive products for cleaning.

(Fig 5) Assembled Driver Side Step Bar Installed

