

iArmor®

IARMOR EDGE™

PART#: IA-N115

BEFORE INSTALLATION

REMOVE CONTENTS FROM BOX. VERIFY ALL PARTS ARE PRESENT. READ INSTRUCTIONS CAREFULLY BEFORE STARTING INSTALLATION. ASSISTANCE IS RECOMMENDED. THANK YOU FOR CHOOSING OUR PRODUCT!

*DRILLING NOT REQUIRED

*TRIMMING NOT REQUIRED

Torque Value

| Fastener Size | Tightening Torque (ft-lbs) | Required |
|---------------|----------------------------|----------|
| 6mm | 6-7 | √ |
| 8mm | 16-18 | √ |
| 10mm | 31-32 | X |
| 12mm | 56-58 | X |
| 14mm | 92-94 | X |

PART LIST

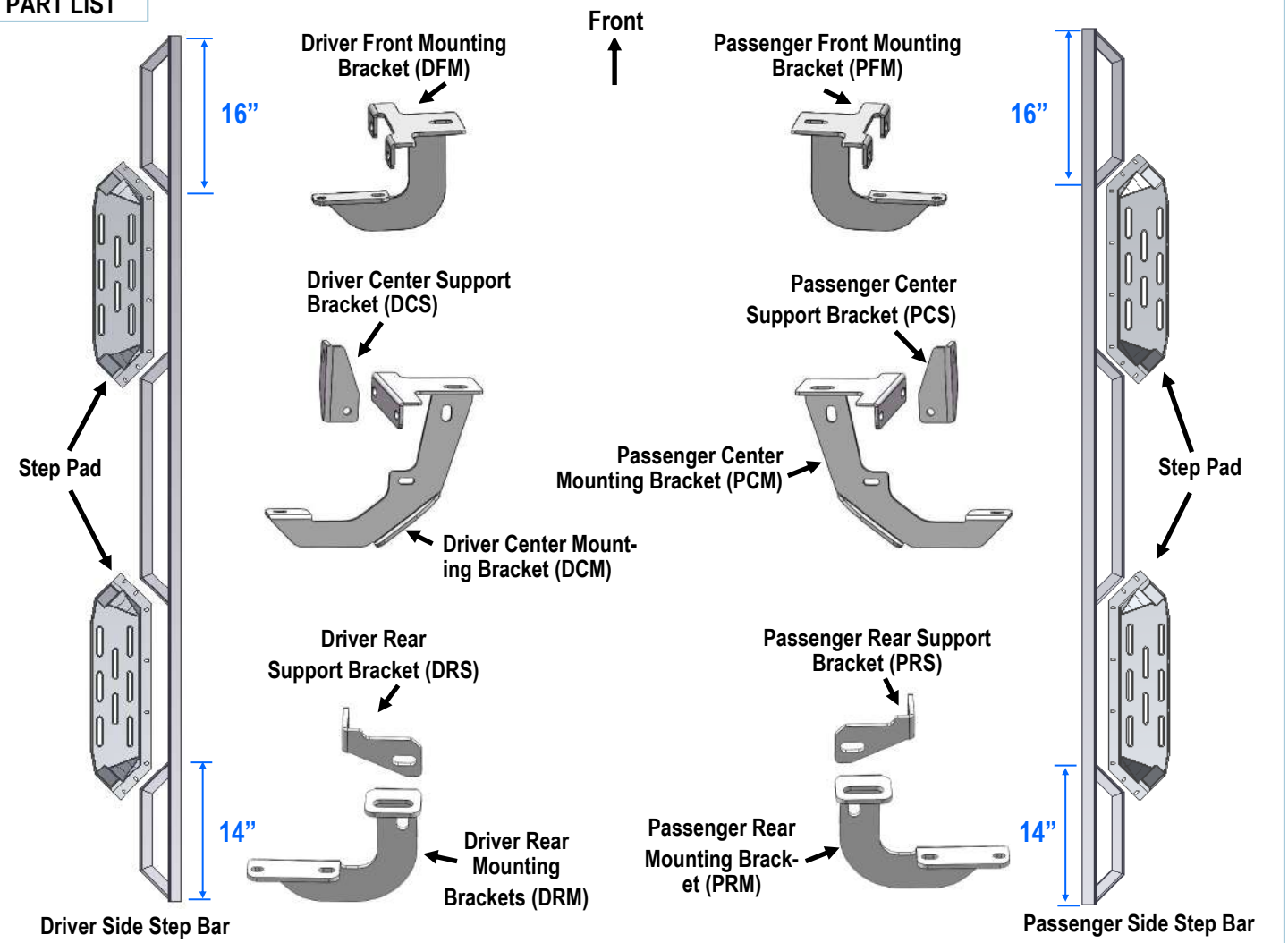

Customer Support: info@iarmorauto.com

iArmor[®]



The instruction here is for your reference only. We strongly recommend the professional installer for best result. We are not responsible for any damage caused by the installation.

STEP 1

Install the Step Pads onto the step bars with (32) M6X1-20mm T-Bolts, (32) M6 Large Flat Washers and (32) M6 Nylon Lock Nuts.

IMPORTANT: Don't hit the step pad by any metal hammer within step pad installation, or the step pad will be damaged.

(8) M6X1-20 T-Bolts
(8) M6 Flat Washers
(8) M6 Nylon Lock Nuts

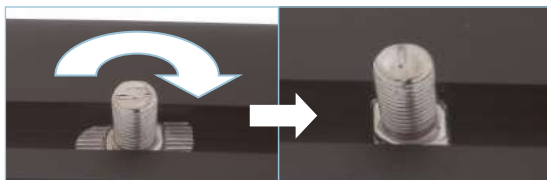

Note: Rotate 90° after inserting the T-Bolts into the Channel!!!

STEP 2

Start installation from the passenger side front of the vehicle. Locate the factory threaded mounting hole at the bottom of the floor, (Fig 1).

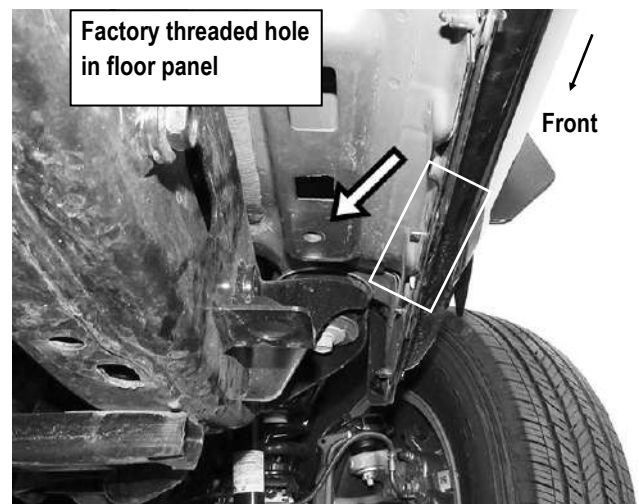

(Fig 1) Passenger Side Front Mounting Location

iArmor®

STEP 3

Select the Passenger Front Mounting Bracket (PFM). Attach the top of the Passenger Front Mounting Bracket to the threaded hole in the bottom of the floor panel with the included (1) M8X1.25-35, Hex Bolt, (1) M8 Lock Washer and (1) M8 Large Flat Washer (Fig 2). Attach the lower (2) holes to the pinch weld with (2) M6X1-25 Hex Bolts, (4) M6 Flat Washers and (2) M6 Nylon Lock Nuts. Do not fully tighten hardware at this time.

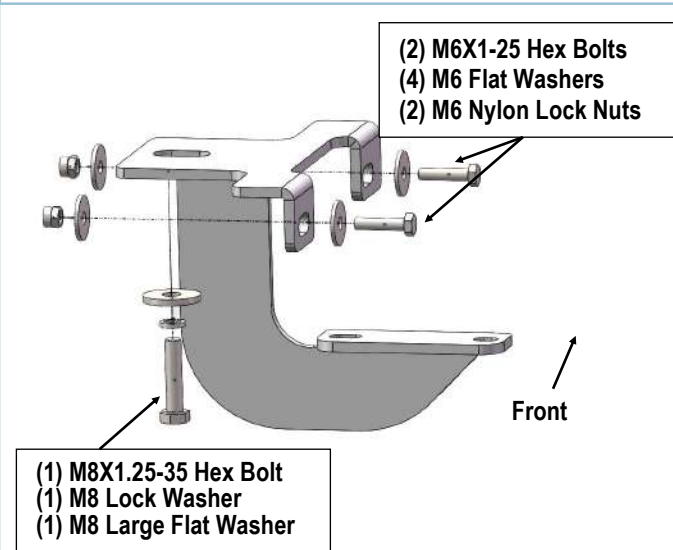

(Fig 2) Passenger Front Mounting Bracket Installed

STEP 4

Move to the passenger side center mounting location, (Fig 3). Assemble Passenger Center Mounting Bracket (PCM) and Passenger Center Support Bracket (PCS) with (1) M8X1.25-35 Hex Bolt, (2) M8 Flat Washers and (1) M8 Nylon Lock Nut, (Fig 4).

Repeat Step 3 to install the assembled passenger center mounting bracket on the mounting location, (Fig 5). Do not fully tighten hardware at this time.

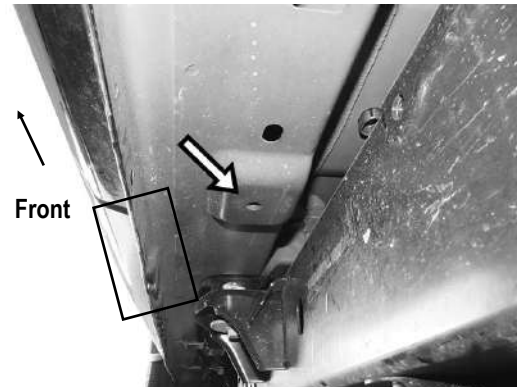

(Fig 3) Passenger Side Center Mounting Location

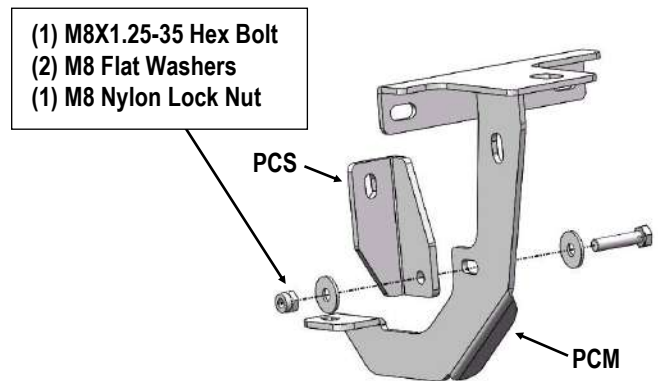

(Fig 4) Passenger Center Mounting Bracket Assembly

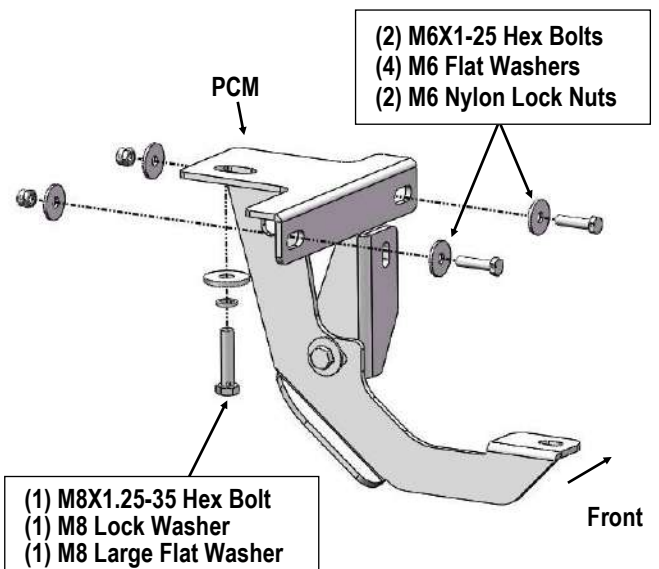

(Fig 5) Passenger Center Bracket Installed

iArmor®

STEP 5

Continue to the rear mounting location (**Fig 6**). Assemble Passenger Rear Mounting Bracket (**PRM**) and Passenger Rear Support Bracket (**PRS**) with (1) M8X1.25-35 Hex Bolt, (2) M8 Flat Washers and (1) M8 Nylon Lock Nut, (**Fig 7**).

Attach the top of the Assembled Passenger Rear Mounting Bracket to the threaded hole in the bottom of the floor panel with (1) M8X1.25-35 Hex Bolt, (1) M8 Lock Washer and (1) M8 Flat Washer (**Fig 8**). Attach Passenger Rear Support Bracket (**PRS**) on the pinch weld with (1) M6X1-25 Hex Bolt, (2) M6 Flat Washers and (1) M6 Nylon Lock Nut. Leave hardware loose at this time.

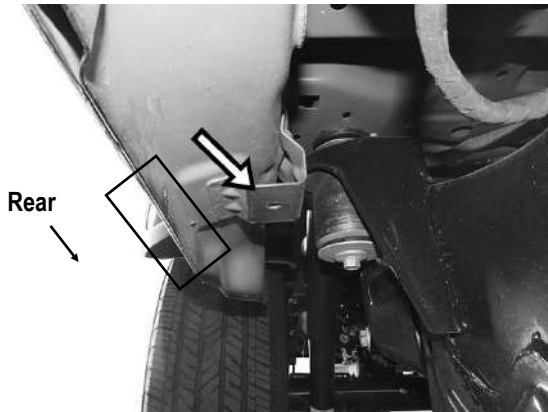

(Fig 6) Passenger Side Rear Mounting Location

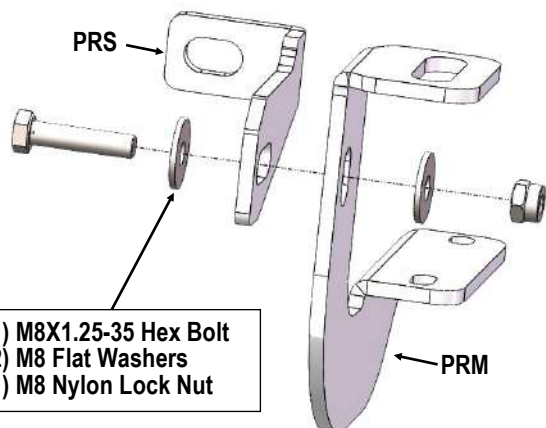

(Fig 7) Passenger Rear Mounting Bracket Assembly

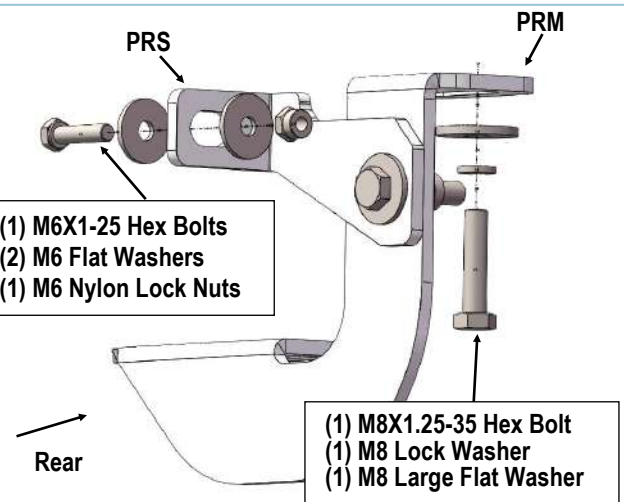

(Fig 8) Passenger Rear Bracket Installed

STEP 6

Once all (3) Brackets have been installed, attach the Assembled Passenger Side Step Bar onto the brackets with (4) M6X1-20 T-Bolts, (2) M6X1-20 Square Head Bolts, (6) M6 Flat Washers and (6) M6 Nylon Lock Nuts (**Fig 9**). Do not fully tighten hardware at this time.

Note: Passenger Side Step Bar is different with the Driver Side. Identify the correct Step Bars carefully, refer to the bar dimensions on the first page.

STEP 7

Properly level and adjust the Step Bar and fully tighten all hardware.

Move to the driver side of the vehicle. Repeat **Steps 2-6** for the Driver Side Step Bar installation.

iArmor®

(Fig 9) Passenger Side Step Bar Installation

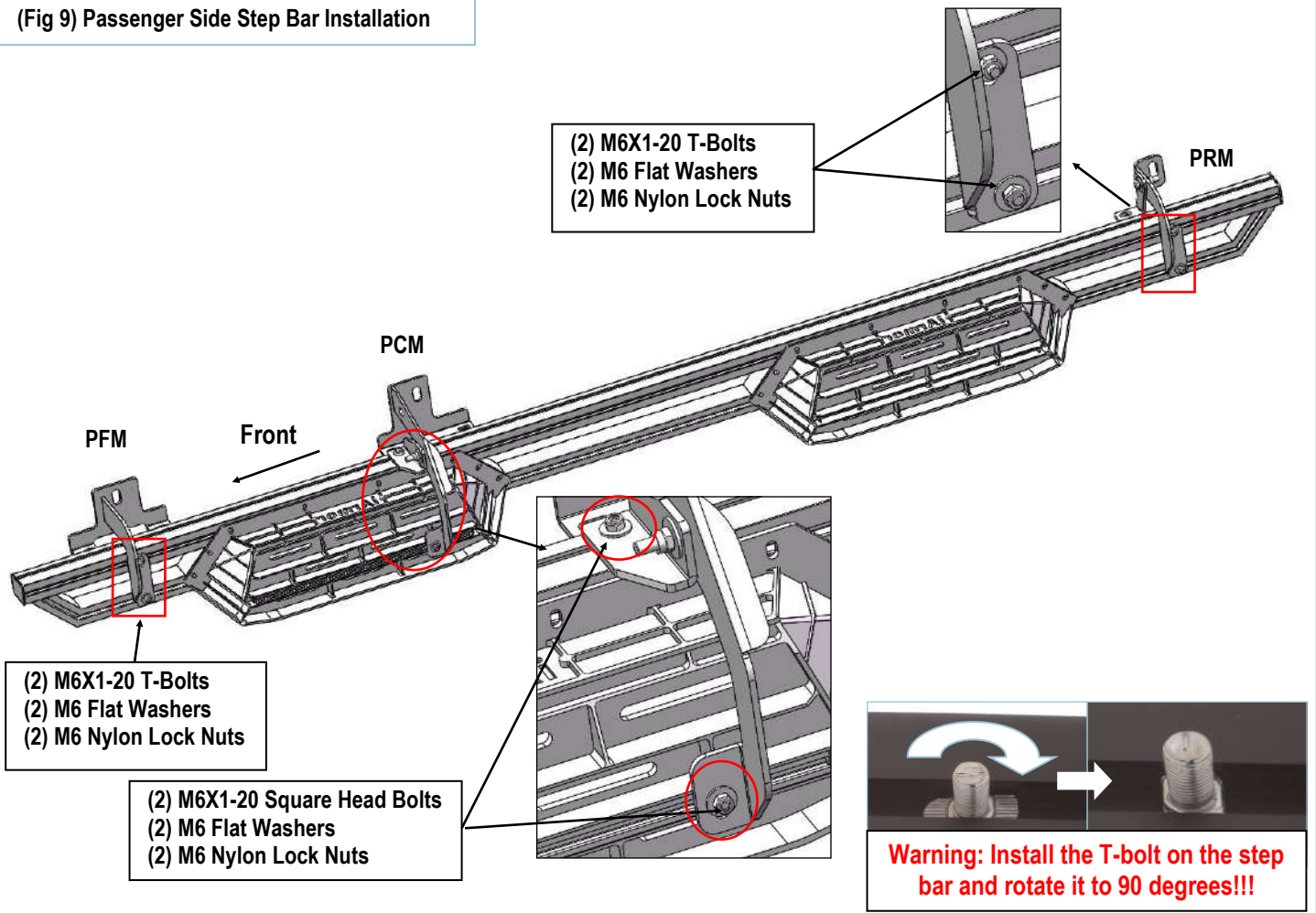

Attention

Do periodic inspections to the installation to make sure that all hardware is secure and tight.
In order to protect your bars/boards, please use only mild soap/non-abrasive products for cleaning.