

IARMOR EDGE™

PART#: IA-N106

BEFORE INSTALLATION

REMOVE CONTENTS FROM BOX. VERIFY ALL PARTS ARE PRESENT. READ INSTRUCTIONS CAREFULLY BEFORE STARTING INSTALLATION. ASSISTANCE IS RECOMMENDED. THANK YOU FOR CHOOSING OUR PRODUCT!

*DRILLING NOT REQUIRED

*TRIMMING NOT REQUIRED

Torque Value

Fastener Size	Tightening Torque (ft-lbs)	Required
6mm	6-7	√
8mm	16-18	√
10mm	31-32	X
12mm	56-58	X
14mm	92-94	X

PART LIST

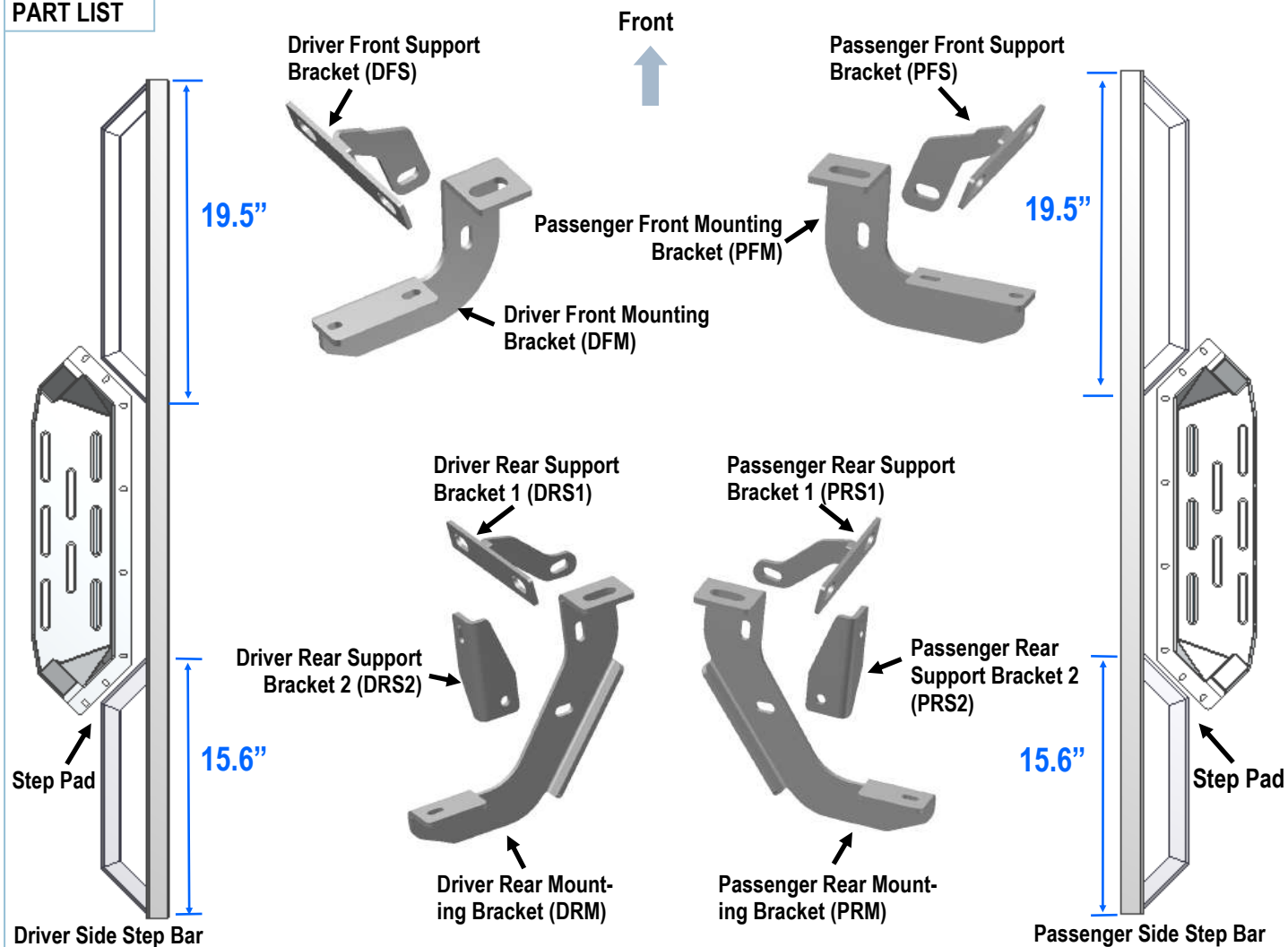

Customer Support: info@iarmorauto.com

iArmor®



The instruction here is for your reference only. We strongly recommend the professional installer for best result. We are not responsible for any damage caused by the installation.

STEP 1

Install the Step Pads onto the step bars with (32) M6X1-20 T-Bolts, (32) M6 Large Flat Washers and (32) M6X1 Nylon Lock Nuts.

IMPORTANT: Don't hit the step pad by any metal hummer within step pad installation, or the step pad will be damaged.

(8) M6X1-20 T-Bolts
(8) M6 Flat Washers
(8) M6X1 Nylon Lock Nuts

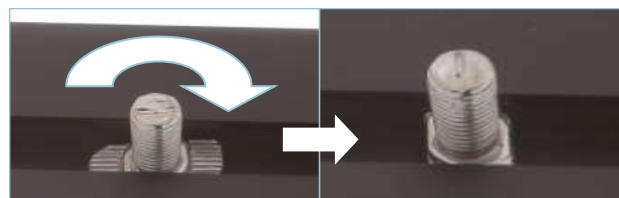

Note: Rotate 90° after inserting the T-Bolts into the Channel!!!

STEP 2

Start installation from the passenger front side of the vehicle. Determine if the vehicle has an open floor panel or a threaded hole in the floor panel:

A. Vehicles with open mounting location:

a. Insert (1) M8X1.25 Nut Plate into the large square opening in the floor panel. Line up the threaded nut with the hole located between the pair of holes on the pinch weld, (Fig 1A, 1B & 2).

b. Move to the Passenger Side Rear Mounting Location, (Fig 3). Repeat **Step 2a** to insert the M8X1.25 Nut Plate into the rear opening on the floor panel.

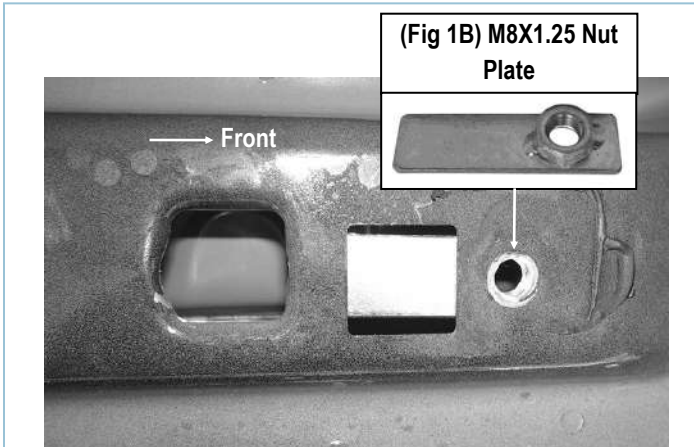

(Fig 1A) Passenger Side Front Mounting Location (Vehicles with open mounting location)

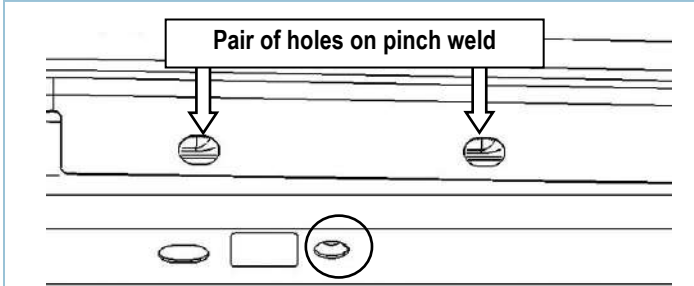

(Fig 2) Line up Nut Plate with hole located between the (2) holes on the pinch weld

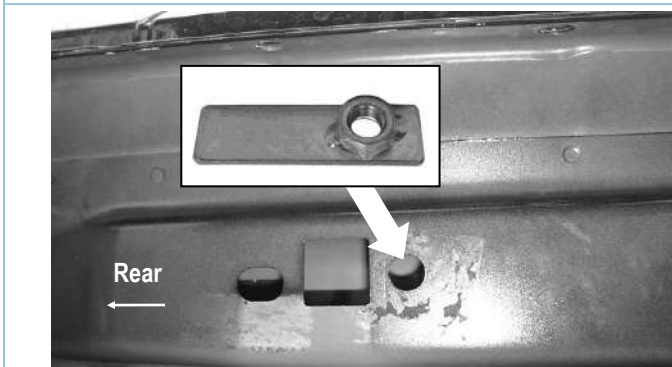

(Fig 3) Passenger Side Rear Mounting Location (Vehicles with open mounting location)

B. Vehicles with factory threaded hole in floor panel:

Locate the passenger side front and rear mounting locations, (Figs 4 & 5). Continue to Step 3.

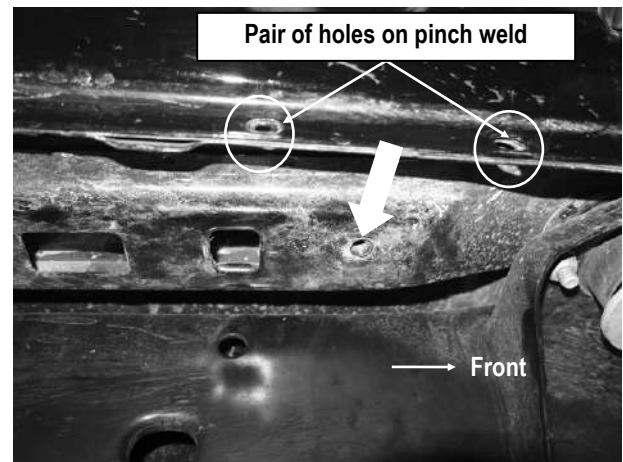

(Fig 4) Passenger Side Front Mounting Location (Vehicles with factory threaded hole in floor panel)



(Fig 5) Passenger Side Rear Mounting Location (Vehicles with factory threaded hole in floor panel)

STEP 3

Assemble Passenger Front Mounting Bracket (PFM) and Passenger Front Support Bracket (PFS) as shown, (Fig 6). Do not fully tighten hardware at this time.

iArmor®

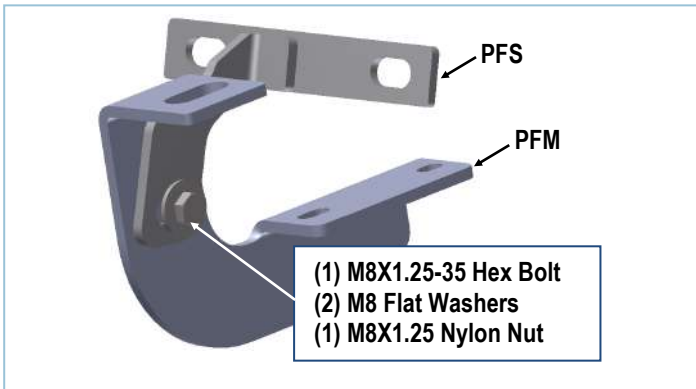

(Fig 6) Passenger Front Mounting Bracket Assembly

STEP 4

Attach the Passenger Front Support Bracket on the **back** of the pinch weld. Secure to the (2) pairs of holes on the pinch weld with (2) M6X1-25 Hex Bolts, (4) M6 Large Flat Washers & (2) M6X1 Nylon Lock Nuts (Figs 7 & 8). Do not fully tighten hardware at this time.

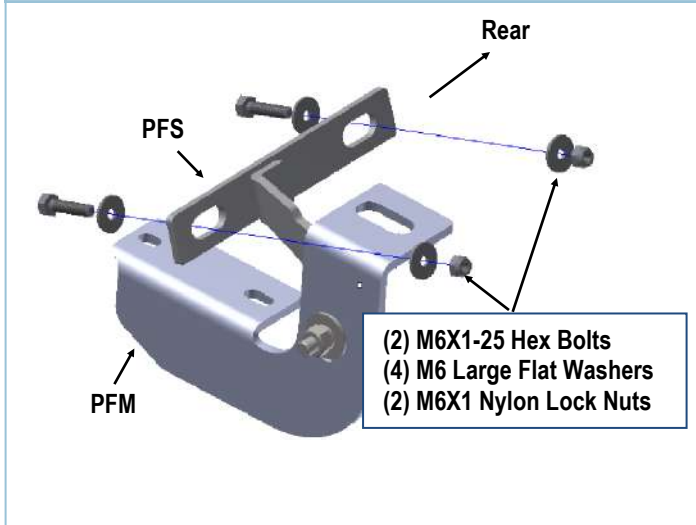

(Fig 7) Passenger Front Support Bracket Installed

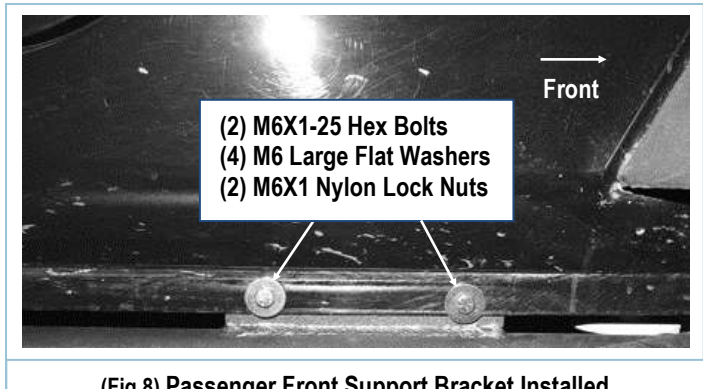

(Fig 8) Passenger Front Support Bracket Installed

STEP 5

Vehicles with open mounting location:
Bolt the Passenger Front Mounting Brackets to the M8X1.25 Nut Plate with (1) M8X1.25-35 Hex Bolt, (1) M8 Lock Washer and (1) M8 Large Flat Washer. (Fig 9). Do not fully tighten hardware at this time.

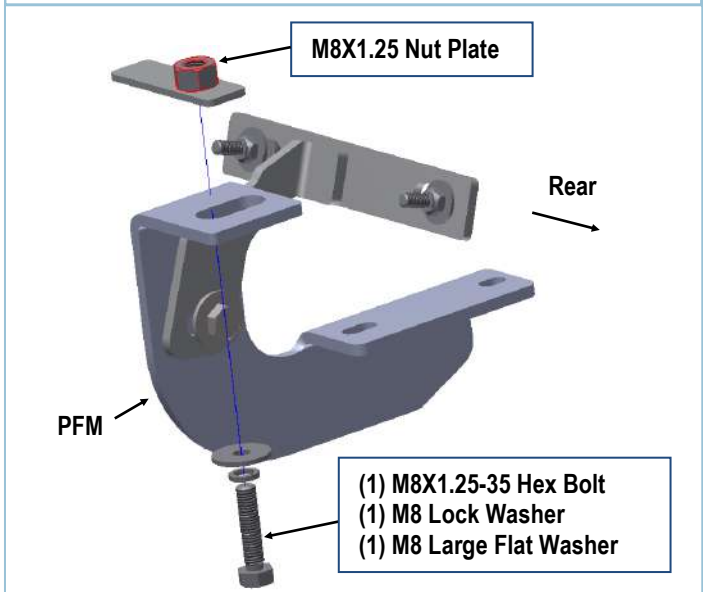

(Fig 9) Passenger Front Mounting Bracket Installed (Vehicles with open mounting location)

iArmor®

STEP 6

Vehicles with factory threaded hole in floor panel:
Bolt the Mounting Bracket to the threaded holes in the floor panel with (1) M8X1.25-35 Hex Bolt, (1) M8 Large Flat Washer, (1) M8 Lock Washer (Figs 10 & 11). Do not fully tighten hardware.

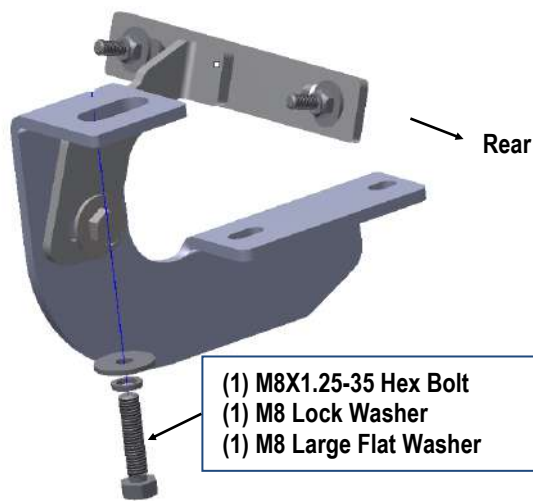

(Fig 10) Passenger Front Mounting Bracket Installed (Vehicles with factory threaded hole in floor panel)

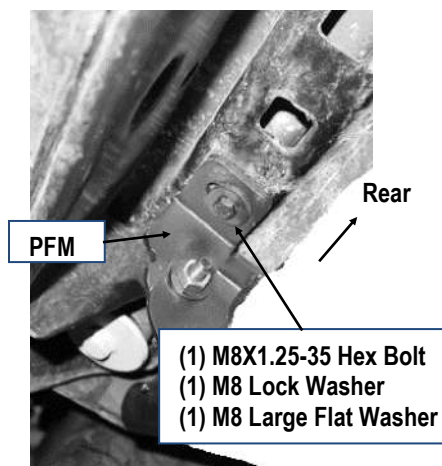

(Fig 11) Passenger Front Mounting Bracket Installed (Vehicles with factory threaded hole in floor panel)

STEP 7

Assemble Passenger Rear Mounting Bracket (PRM) and Passenger Rear Support Brackets (PRS1 & PRS2) (Fig 12). Do not fully tighten hardware at this time.

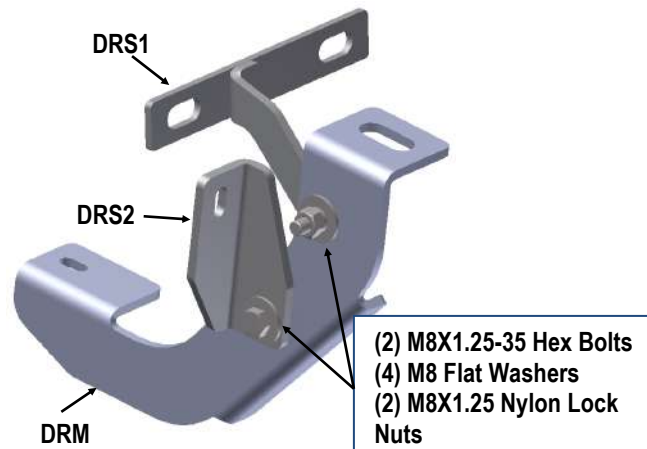

(Fig 12) Passenger Rear Mounting Bracket Assembly

STEP 8

Install the Assembled Passenger Rear Mounting Bracket onto the vehicle, (Figs 13-16).

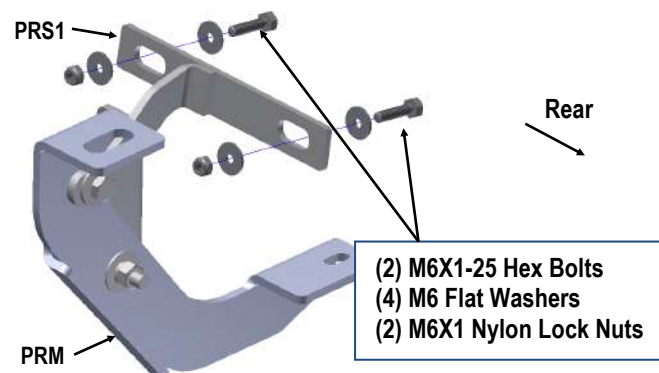

(Fig 13) Passenger Rear Support Bracket 1 Mounted to Pinch Weld

iArmor®

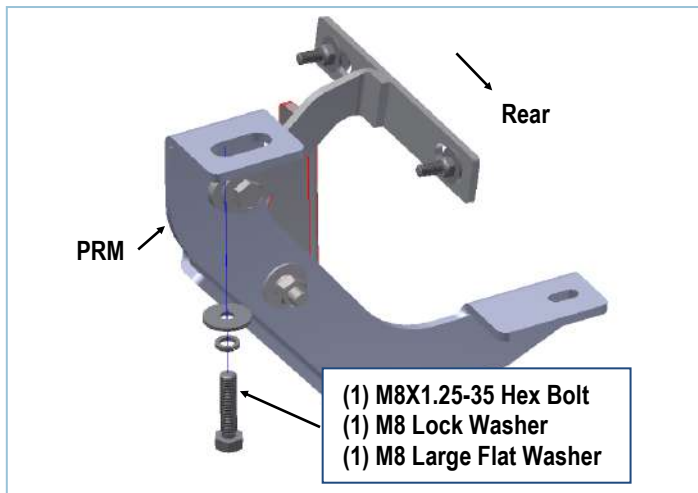

(Fig 14) Passenger Rear Mounting Bracket Installed
(Vehicles with factory threaded hole in floor panel)

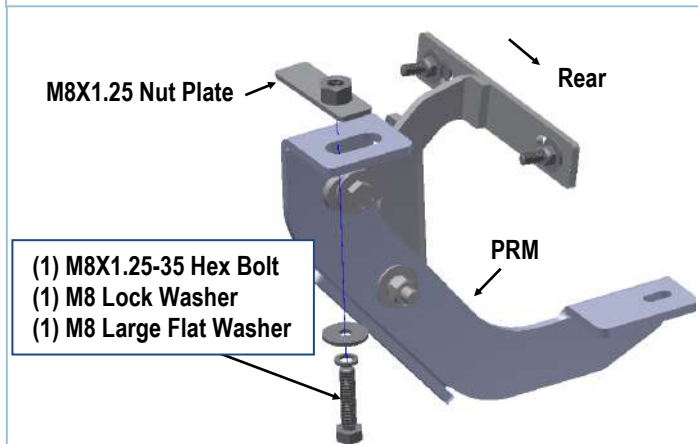

(Fig 15) Passenger Rear Mounting Bracket Installed
(Vehicles with open mounting location)

STEP 9

Once (2) passenger side brackets are installed, attach the Assembled Passenger Side Step Bar onto the Mounting Brackets with (2) M6X1-20 T-Bolts, (2) M6X1-20 Square Head Bolts, (4) M6 Flat Washers and (4) M6x1 Nylon Lock Nuts, (Fig 17). Do not tighten hardware.

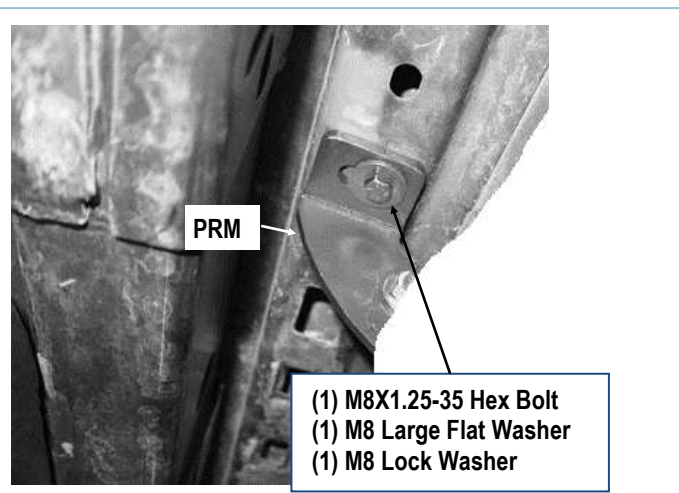

(Fig 16) Passenger Rear Mounting Bracket Installed

STEP 10

Level and adjust the Assembled Passenger Side Step Bar properly and tighten all hardware.

Repeat **Steps 2-9** for the Driver Side Step Bar installation.

Attention

Do periodic inspections to the installation to make sure that all hardware is secure and tight.

In order to protect your bars/boards, please use only mild soap/non-abrasive products for cleaning.

iArmor®

