

iArmor[®]

iArmor[®] by APS

PART#: IA-S107

BEFORE INSTALLATION

REMOVE CONTENTS FROM BOX. VERIFY ALL PARTS ARE PRESENT. READ INSTRUCTIONS CAREFULLY BEFORE STARTING INSTALLATION. ASSISTANCE IS RECOMMENDED. THANK YOU FOR CHOOSING OUR PRODUCT!

***ROCKER PANEL MOUNT**

***NO DRILLING / TRIMMING REQUIRED**

Torque Value

Fastener Size	Tightening Torque (ft-lbs)	Required
6mm	6-7	√
8mm	16-18	√
10mm	31-32	X
12mm	56-58	X
14mm	92-94	X

PART LIST

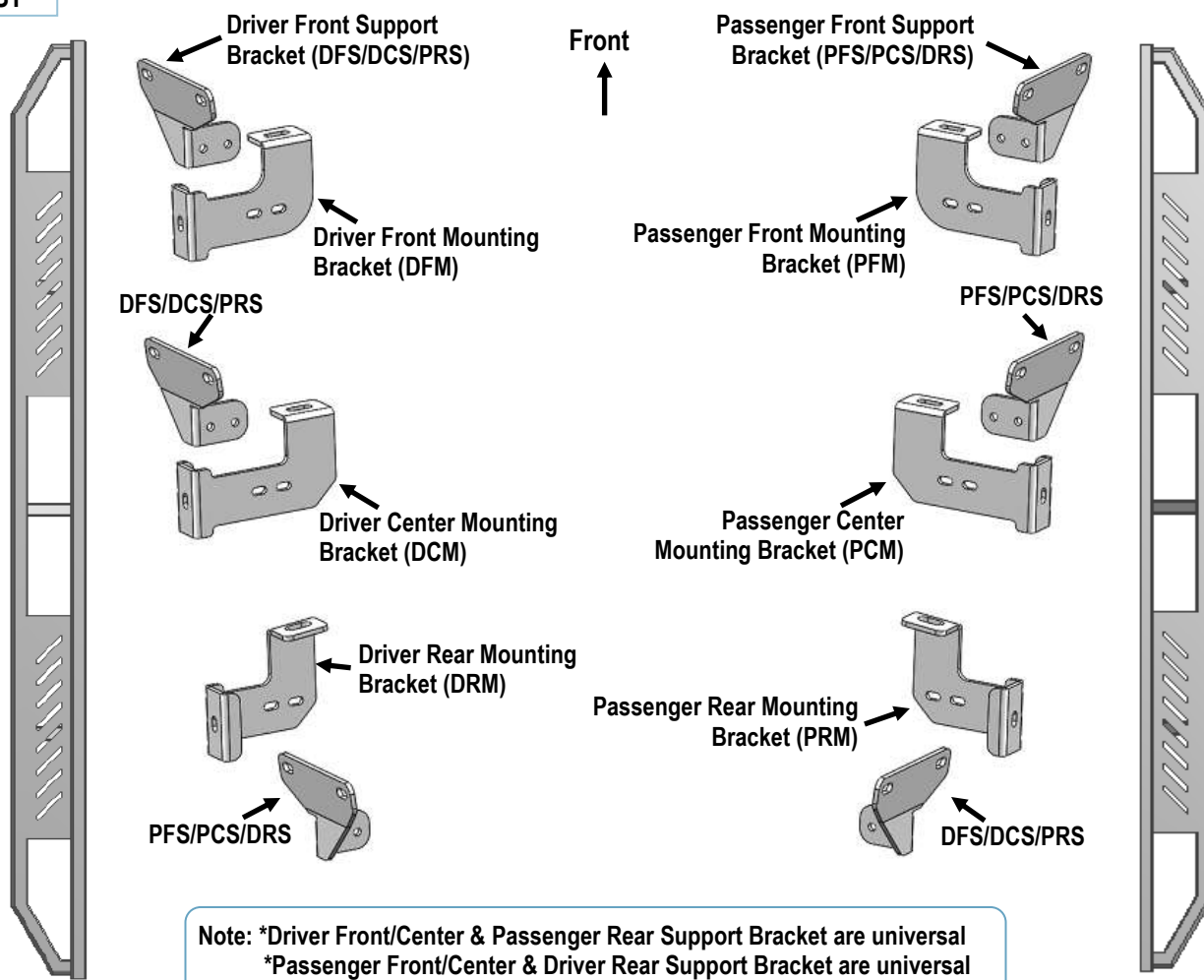

Customer Support: info@iarmorauto.com

iArmor®

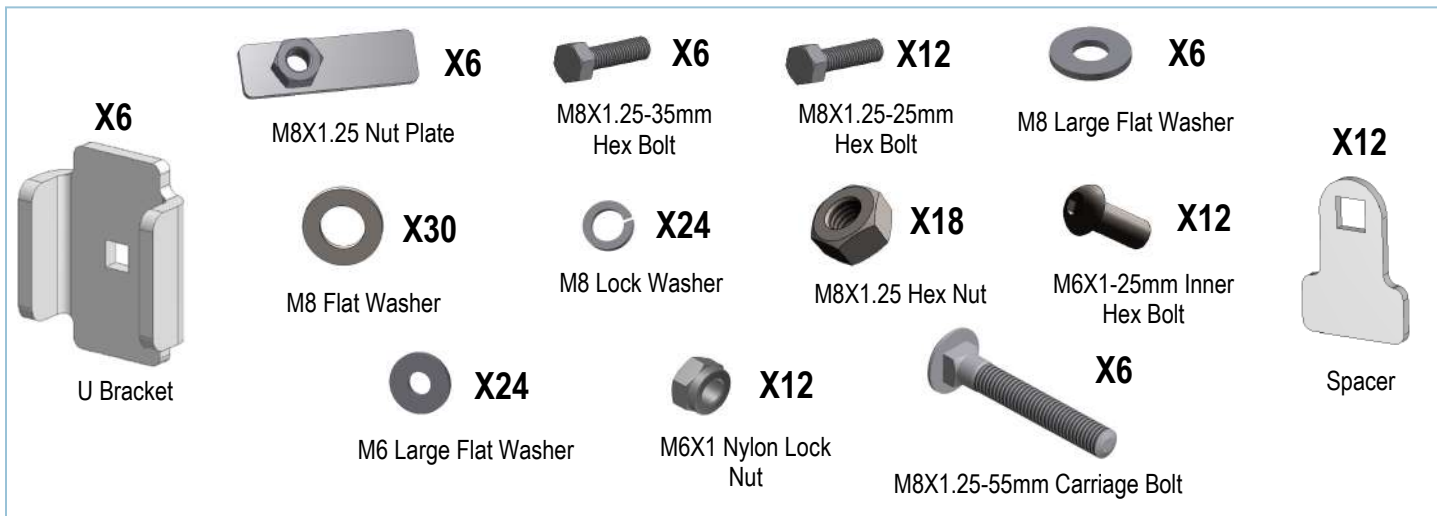

The instruction here is for your reference only. We strongly recommend the professional installer for best result. We are not responsible for any damage caused by the installation.

STEP 1

THE FACTORY ROCK RAILS, SIDE STEPS OR RUNNING BOARDS MUST BE REMOVED BEFORE INSTALLING.

Start installation from the passenger side front of the vehicle. Determine if the vehicle has an opening or a threaded hole in the floor panel on the mounting location, (**Figs 1 - 2**). Remove any insulation that may be covering the mounting locations.

Insert M8X1.25 Nut Plate Into Opening And Line Up the Welded Nut With the Mounting Hole

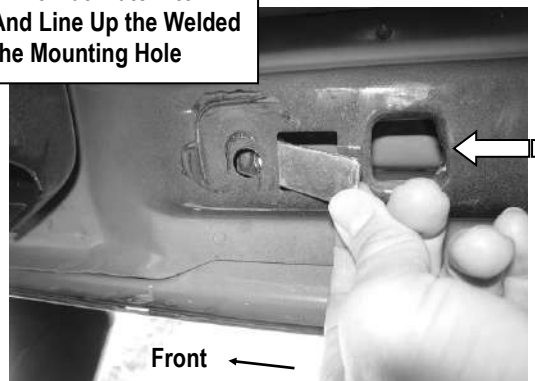

(Fig 1) Vehicle with opening In Floor Panel (Passenger Side-Front Mounting Location)



(Fig 2) Vehicle with 8mm Threaded Hole In Floor Panel

STEP 2

Assemble (3) Passenger Side Mounting Brackets and Passenger Support Brackets as shown, (Figs 3-5). Do not fully tighten hardware at this time.

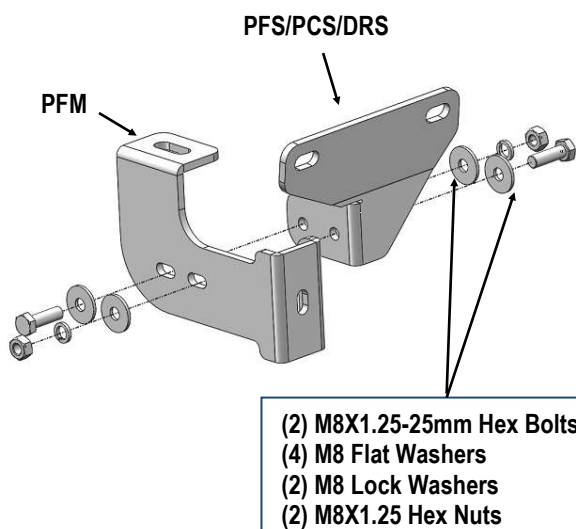

(Fig 3) Passenger Front Mounting Bracket Assembly

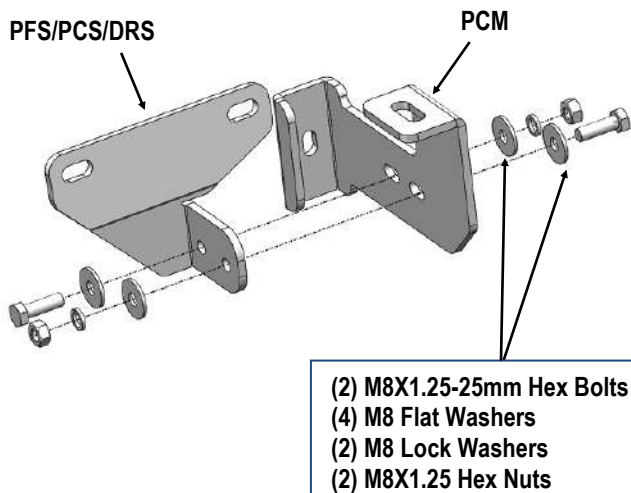

(Fig 4) Passenger Center Mounting Bracket Assembly

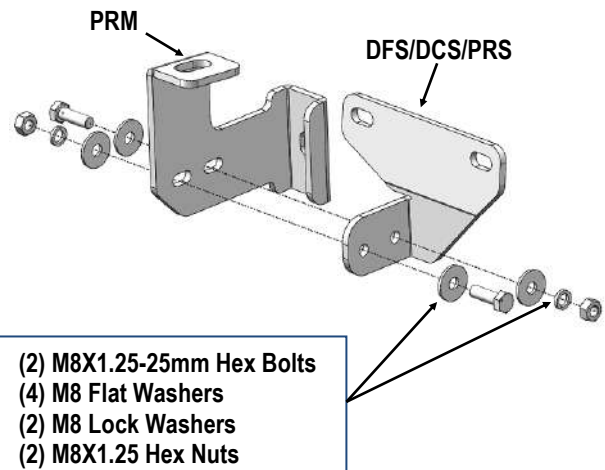

(Fig 5) Passenger Rear Mounting Bracket Assembly

STEP 3

Select the assembled Passenger Front Mounting Bracket.

Vehicles with opening in the floor panel (Fig 1):

Insert (1) M8X1.25 Nut Plate into the large square opening in the floor panel. Line up the threaded nut with the small round hole, (Fig 1). Bolt the Mounting Bracket to the M8X1.25 Nut Plate with (1) M8X1.25-35mm Hex Bolt, (1) M8 Lock Washer and (1) M8 Large Flat Washer, (Fig 6). Do not fully tighten hardware.

Vehicles with factory threaded hole in floor panel (Fig 2):

Bolt the upper hole of the mounting bracket to the threaded hole in the floor panel with (1) M8X1.25-35mm Hex Bolt, (1) M8 Lock Washer and (1) M8 Large Flat Washer, (Figs 6 & 7). Do not fully tighten hardware.

STEP 4

Repeat **Steps 1—3** to install the assembled **Passenger Center and Rear Mounting Brackets**. Do not fully tighten hardware at this time.

STEP 5

Once all (3) passenger side mounting brackets are installed, select and attach the Passenger Side Step Bar onto the Mounting Brackets with (3) U Brackets, (6) Spacers, (3) M8X1.25-55mm Carriage Bolts, (3) M8 Flat Washers, (3) M8 Lock Washers and (3) M8X1.25 Hex Nuts (**Fig 8**). Do not fully tighten hardware at this time.

STEP 6

Properly level and adjust the Step Bar and fully tighten all hardware.

STEP 7

Move to the driver side of the vehicle. Repeat **Steps 1-6** to install driver side step bar.

Installation completed.

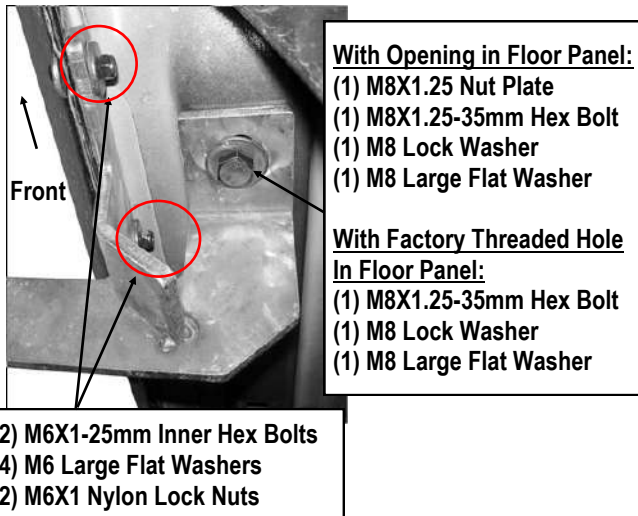

(Fig 6) Passenger Front Brackets Installation

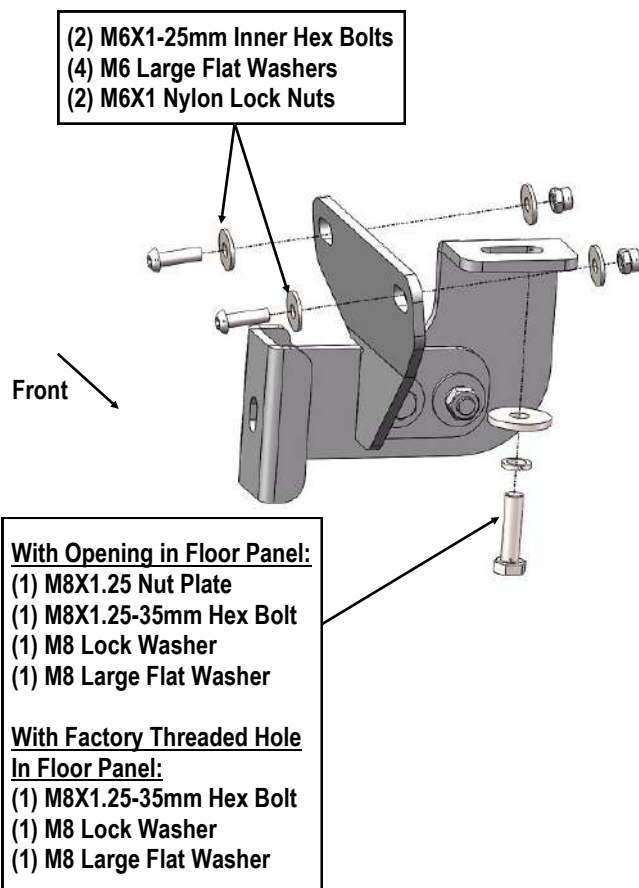

(Fig 7) Passenger Front Brackets Installation

iArmor®

NOTE: Torque all M8 X1.25-55mm Carriage Bolts to 16~18 lb-ft. Don't over tighten, or the aluminum square bars will be damaged by the brackets

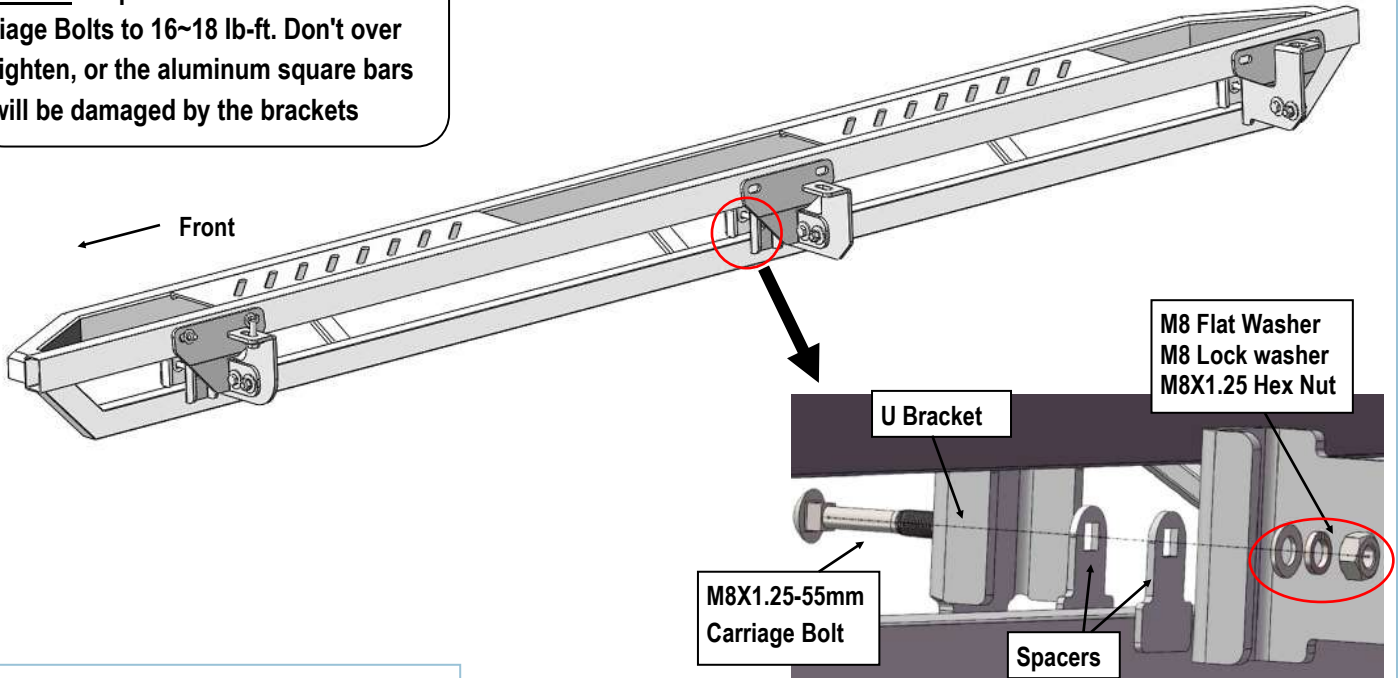

(Fig 8) Passenger Side Step Bar Installed

Attention

Do periodic inspections to the installation to make sure that all hardware is secure and tight.
In order to protect your bars/boards, please use only mild soap/non-abrasive products for cleaning.