

iArmor®

IARMOR EDGE™

PART#: IA-W111

BEFORE INSTALLATION

REMOVE CONTENTS FROM BOX. VERIFY ALL PARTS ARE PRESENT. READ INSTRUCTIONS CAREFULLY BEFORE STARTING INSTALLATION. ASSISTANCE IS RECOMMENDED. THANK YOU FOR CHOOSING OUR PRODUCT!

*ROCKER PANEL MOUNT

*DRILLING/TRIMMING NOT REQUIRED

Torque Value

Fastener Size	Tightening Torque (ft-lbs)	Required
6mm	6-7	√
8mm	16-18	√
10mm	31-32	√
12mm	56-58	X
14mm	92-94	X

PART LIST

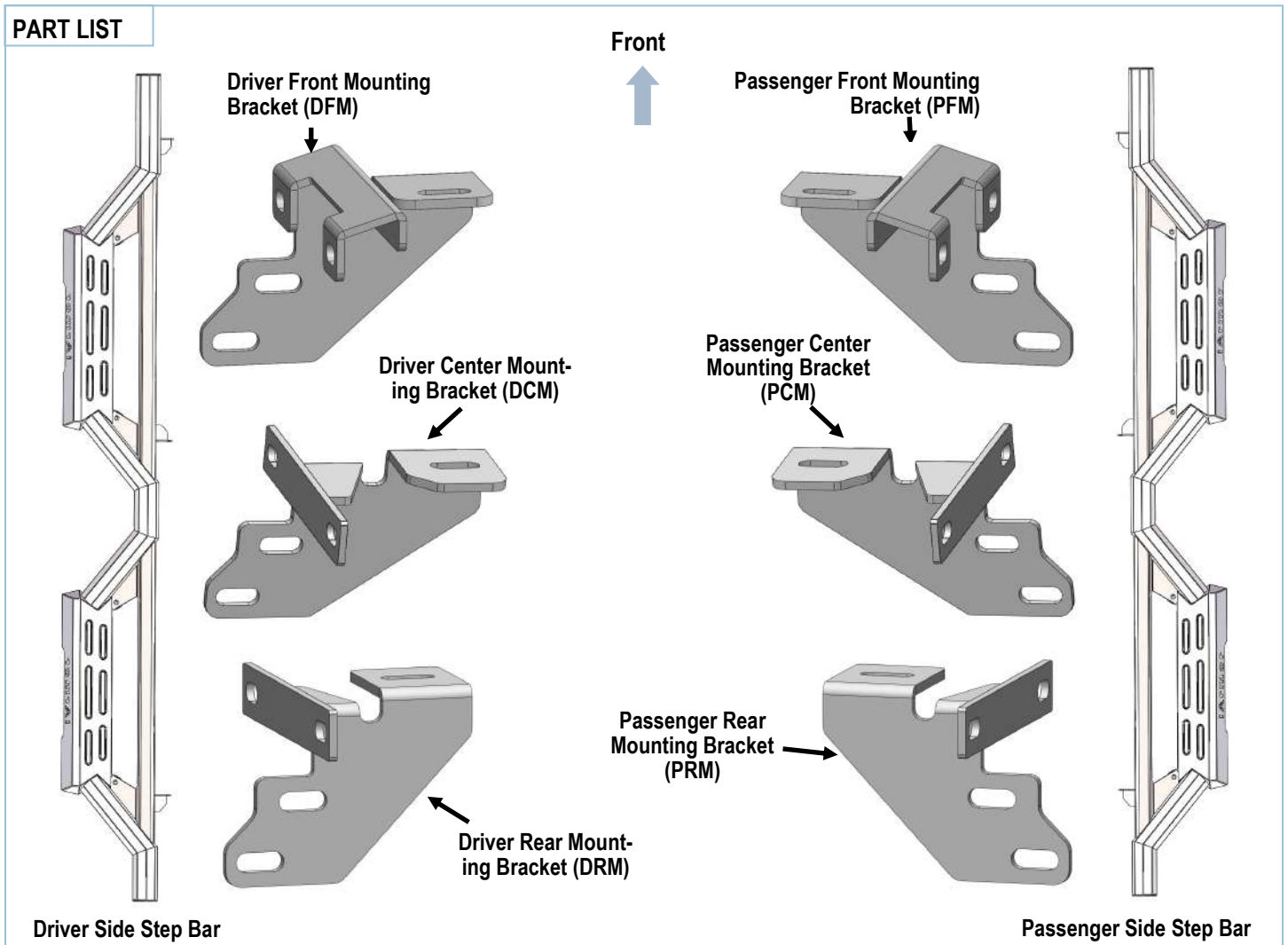

Customer Support: info@iarmorauto.com

iArmor[®]

Hardware Package (For Brackets & Step Bars Installation)					
Item	QTY	Description	Item	QTY	Description
1#	6	M8X1.25-35 Hex Bolts	6#	12	M6X1 Nylon Lock Nuts
2#	6	M8 Large Flat Washers	7#	12	M10X1.5-25 Hex Bolts
3#	6	M8 Lock Washers	8#	24	M10 Flat Washers
4#	12	M6X1-25 Hex Bolts	9#	12	M10 Nylon Lock Nuts
5#	24	M6 Large Flat Washers			

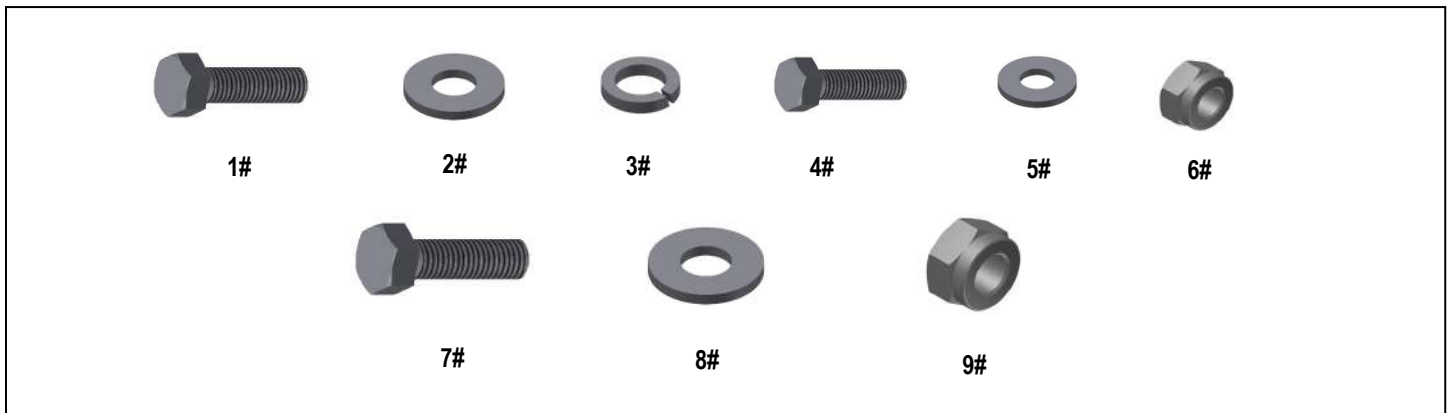

iArmor[®]

The instruction here is for your reference only. We strongly recommend the professional installer for best result. We are not responsible for any damage caused by the installation.

STEP 1

Start from the Passenger side front of the vehicle. Locate the factory mounting holes on the pinch weld and the small factory threaded hole on the floor panel directly behind the pinch weld. (Fig 1).

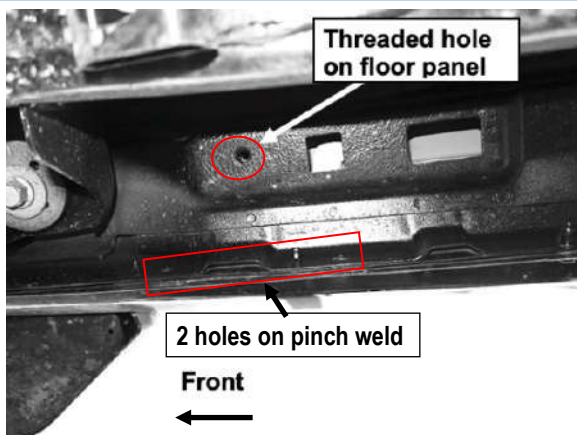

(Fig 1) Passenger Side Front Mounting Location

STEP 2

Select the Passenger Front Mounting Bracket (PFM). Attach the top of the bracket to the factory threaded hole with the included (1) M8X1.25-35 Hex Bolt, (1) M8 Lock Washers and (1) M8 Large Flat Washer. Attach the lower (2) holes to the pinch weld with (2) M6X1-25 Hex Bolts, (4) M6 Large Flat Washers and (2) M6 Nylon Lock Nuts, (Fig 2). Do not fully tighten hardware at this time.

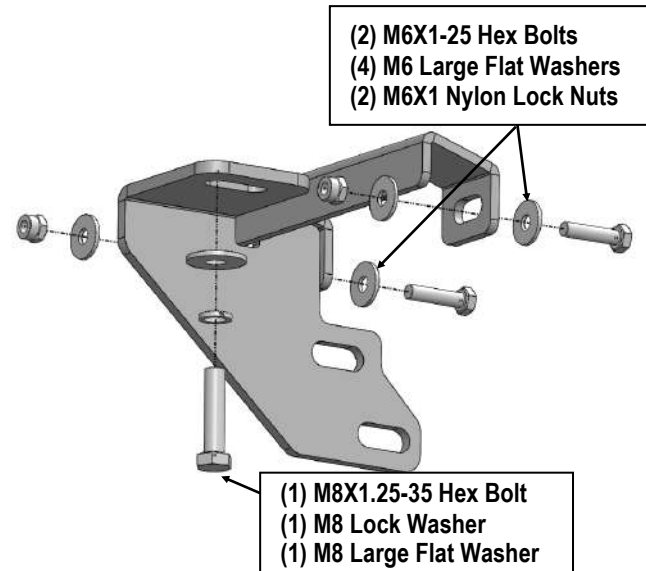

(Fig 2) Passenger Front Mounting Bracket Installation

STEP 3

Move to the passenger side center mounting location, (Fig 3). Repeat Step 2 to install the Passenger Center Mounting Bracket (PCM), (Fig 4). Do not fully tighten hardware at this time.

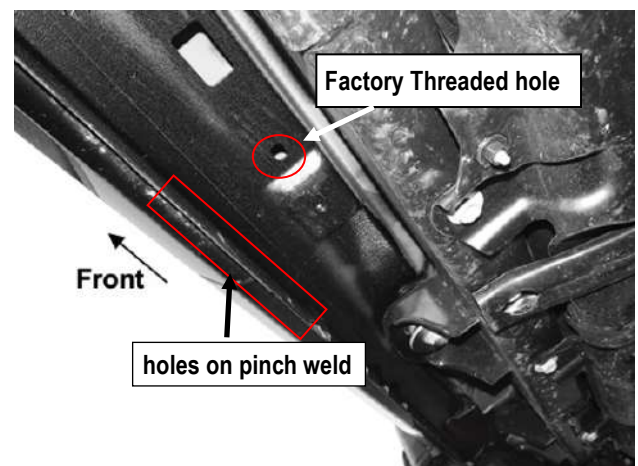

(Fig 3) Passenger Side Center Mounting Location

iArmor[®]

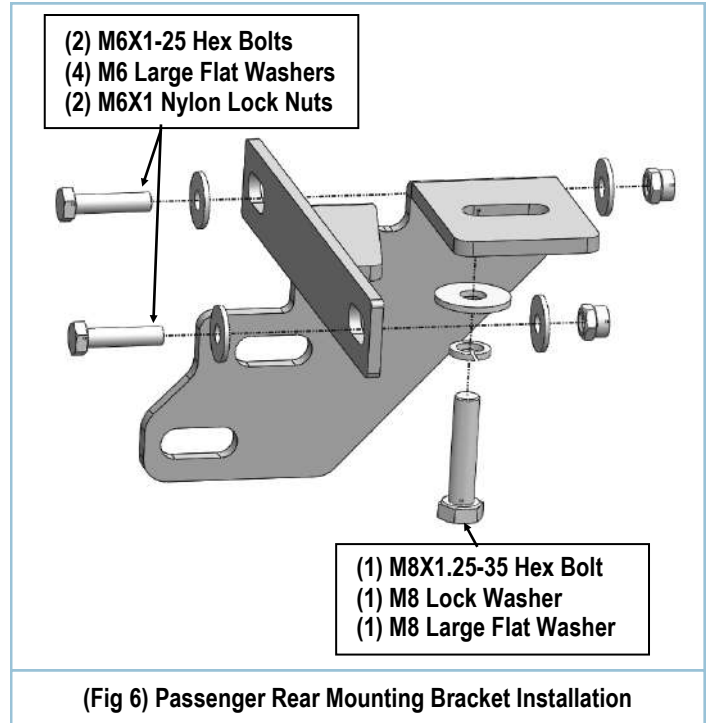
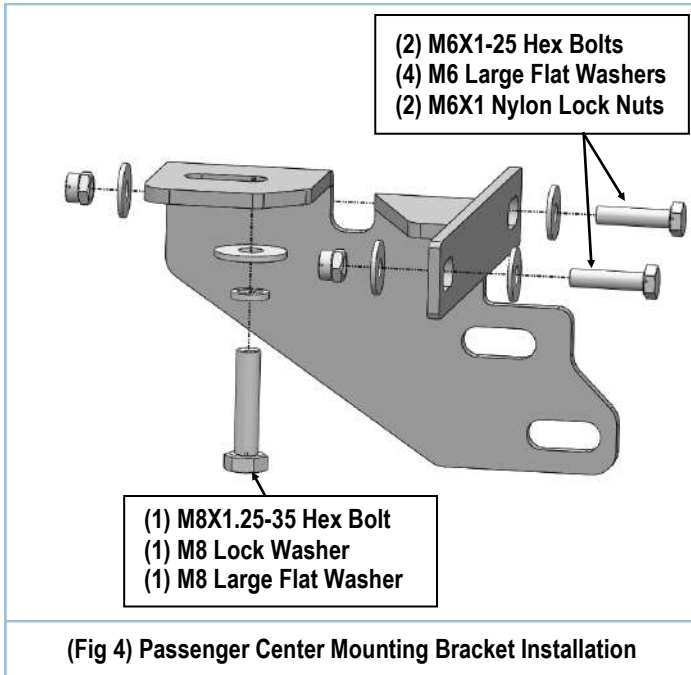

STEP 4

Continue to the Passenger Side Rear Mounting Location (**Fig 5**). Repeat **Step 2** to install the Passenger Rear Mounting Bracket (**PRM**), (**Fig 6**). Do not fully tighten hardware at this time.

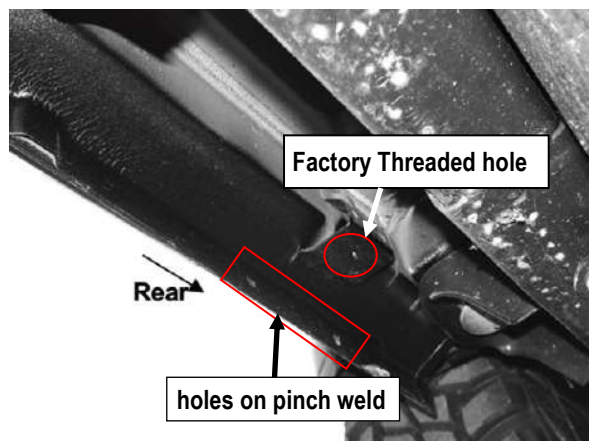

(Fig 5) Passenger Side Rear Mounting Location

STEP 5

Once all (3) Mounting Brackets have been installed, attach the Passenger Side Step Bar to the Mounting Brackets with (6) M10X1.5-25 Hex Bolts, (12) M10 Flat Washers and (6) M10X1.5 Nylon Lock Nuts, (**Fig 8**). Do not fully tighten hardware at this time.

STEP 6

Properly level and adjust the Step Bar and fully tighten all hardware.

iArmor[®]

STEP 7

Move to the other side of the vehicle. Repeat **Steps 1-6** for the other Side Step Bar installation.

Attention

Do periodic inspections to the installation to make sure that all hardware is secure and tight.

In order to protect your bars/boards, please use mild soap/non-abrasive products for cleaning only.

