

# iArmor®

## IARMOR EDGE™

PART#: IA-W107H

### BEFORE INSTALLATION

REMOVE CONTENTS FROM BOX. VERIFY ALL PARTS ARE PRESENT. READ INSTRUCTIONS CAREFULLY BEFORE STARTING INSTALLATION. ASSISTANCE IS RECOMMENDED. THANK YOU FOR CHOOSING OUR PRODUCT!

\*ROCKER PANEL MOUNT

\*DRILLING/TRIMMING NOT REQUIRED

### Torque Value

Fastener Size	Tightening Torque (ft-lbs)	Required
6mm	6-7	√
8mm	16-18	√
10mm	31-32	√
12mm	56-58	X
14mm	92-94	X

### PART LIST

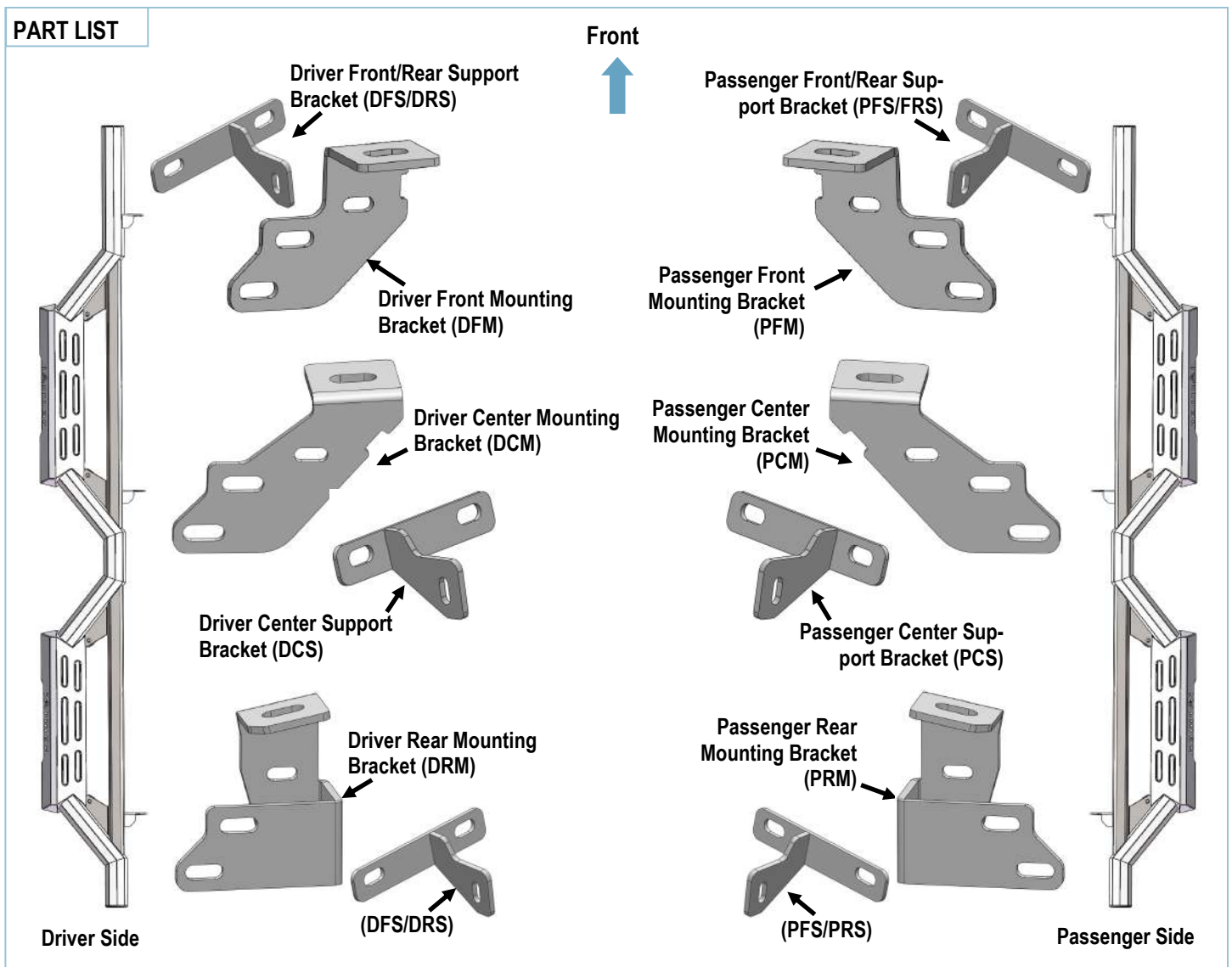

Customer Support: [info@iarmorauto.com](mailto:info@iarmorauto.com)

# iArmor<sup>®</sup>

## Hardware Package (For Brackets & Step Bars Installation)

Item	QTY	Description	Item	QTY	Description
1#	6	M8X1.25 Nut Plate	7#	12	M6X1-25 Hex Bolts
2#	12	M8X1.25-35 Hex Bolts	8#	24	M6 Large Flat Washers
3#	6	M8 Large Flat Washers	9#	12	M6X1 Nylon Lock Nuts
4#	6	M8 Lock Washers	10#	12	M10X1.5-25 Hex Bolts
5#	12	M8 Flat Washers	11#	24	M10 Flat Washers
6#	6	M8X1.25 Nylon Lock Nuts	12#	12	M10X1.5 Nylon Lock Nuts



1#



2#



3#



4#



5#



6#



7#



8#



9#



10 #



11 #



12 #

# iArmor®

The instruction here is for your reference only. We strongly recommend the professional installer for best result. We are not responsible for any damage caused by the installation.

## STEP 1

Start installation from the driver side front of the vehicle. Determine if the vehicle with open mounting locations or factory threaded holes in the floor panel.

### A. Vehicles with open mounting location:

a. Insert (1) M8X1.25 Nut Plate into the large square opening in the floor panel. Line up the threaded nut with the hole in between the pair of holes on the pinch weld, (Fig 1A, 1B & 2).

b. Move along to the center/ rear mounting location, (Fig 3). Repeat **Step 2a** to insert the Nut Plate into the center/ rear opening on the floor panel.

### B. Vehicles with factory threaded hole in floor panel:

Locate the front ,center and rear mounting locations, (Figs 4 & 5). Continue to **Step 2**.

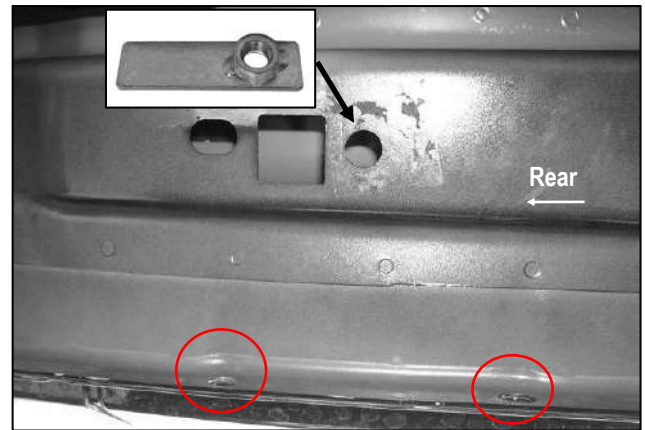

(Fig 3) Driver Side Center/Rear Mounting Location (Vehicles with open mounting location)

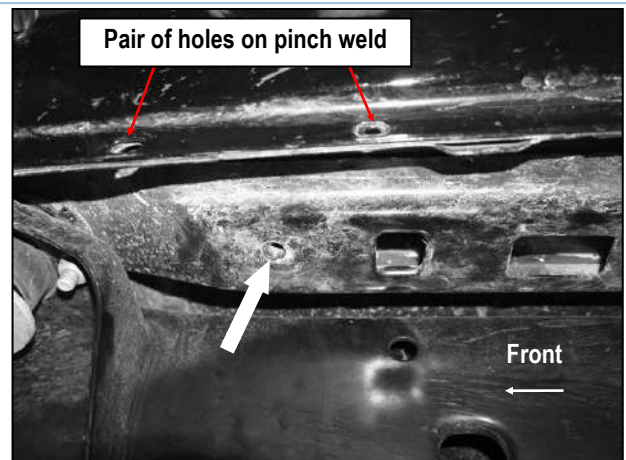

(Fig 4) Driver Side Front Mounting Location (Vehicles with factory threaded hole in floor panel)



(Fig 5) Driver Side Center & Rear Mounting Location (Vehicles with factory threaded hole in floor panel)

(Fig 1B) Nut Plate

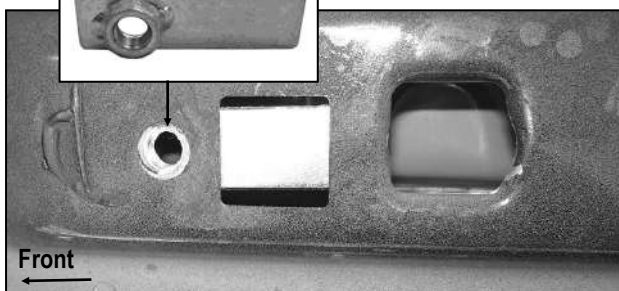

(Fig 1A) Driver Side Front Mounting Location (Vehicles with open mounting location)

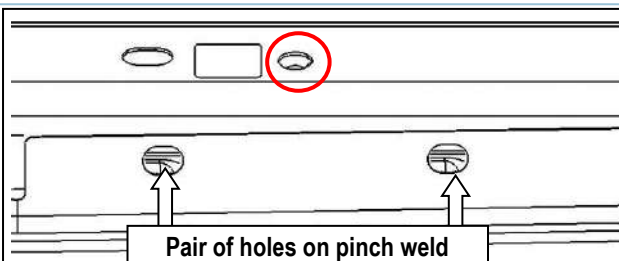

(Fig 2) Line up Nut Plate with hole between the (2) holes on the pinch weld

# iArmor®

## STEP 2

Assemble (3) Driver Side Mounting Brackets and Driver Side Support Brackets (Figs 6-8). Do not fully tighten hardware at this time.

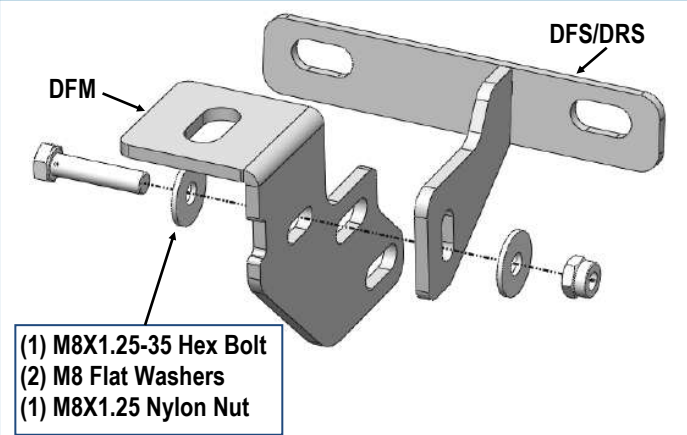

(Fig 6) Driver Front Mounting Bracket Assembly

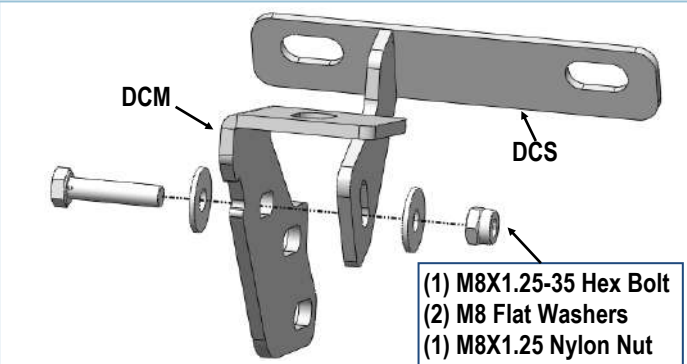

(Fig 7) Driver Center Mounting Bracket Assembly

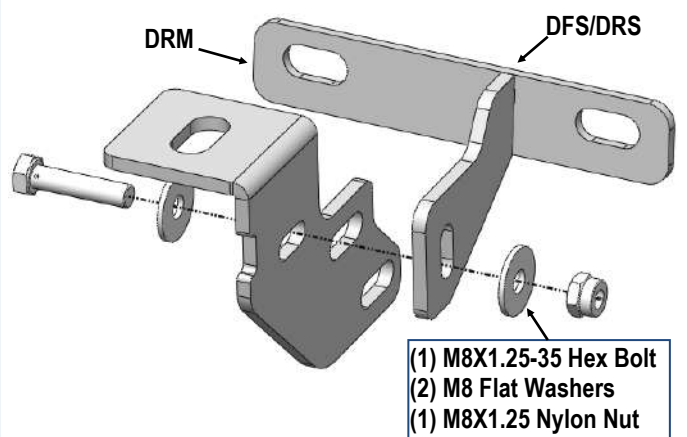

(Fig 8) Driver Rear Mounting Bracket Assembly

## STEP 3

On Driver Side Front Mounting Location. Attach the Driver Support Bracket (DFS/PRS) on the **back** of the pinch weld. Secure to the (2) pairs of holes on the pinch weld with (2) M6X1-25 Hex Bolts, (4) M6 Large Flat Washers & (2) M6X1 Nylon Lock Nuts, (Figs 9 & 10). Don't fully tighten hardware at this time.

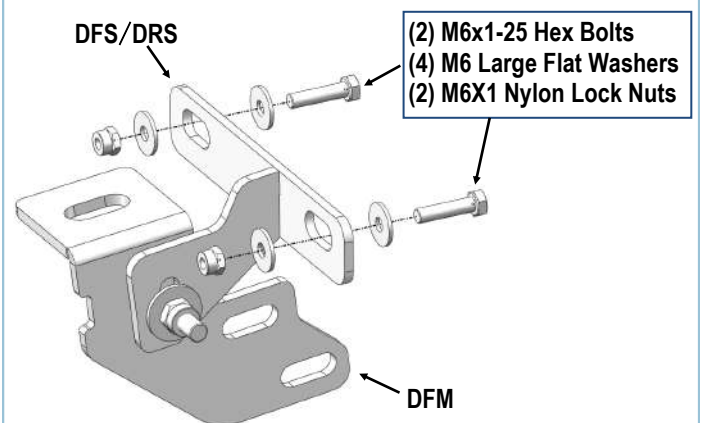

(Fig 9) Driver Front Support Bracket Installation

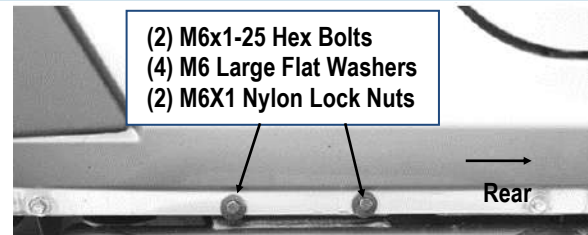

(Fig 10) Driver Front Support Bracket Installed

## STEP 4

**Vehicles with open mounting location:**

Bolt the Driver Front Mounting Bracket to the installed M8X1.25 Nut Plate with (1) M8X1.25-35 Hex Bolt, (1) M8 Lock Washer and (1) M8 Large Flat Washer, (Fig 11). Do not fully tighten hardware at this time.

**Vehicles with factory threaded hole in floor panel:**

Bolt the Mounting Bracket to the threaded hole on the floor panel with (1) M8X1.25-35 Hex Bolt, (1) M8 Large Flat Washer, (1) M8 Lock Washer, (Figs 12 & 13). Do not fully tighten hardware at this time.

# iArmor®

## STEP 5

Move to the Driver Side Center and Rear Mounting Location. Repeat **steps 1-4** to install the Assembled Driver Center and Rear Brackets. Do not fully tighten hardware at this time.

## STEP 6

Once all (3) Mounting Brackets have been installed, attach the Driver Side Bar to the assembled Bar Brackets with (6) M10X1.5-25 Hex Bolts, (12) M10 Flat Washers and (6) M10X1.5 Nylon Lock Nuts, (**Fig 14**). Do not fully tighten hardware at this time.

Properly level and adjust the Step Bar and fully tighten all hardware.

## STEP 7

Move to the other side of the vehicle. Repeat **Steps 1-6** for the other side step bar installation.

### Attention

Do periodic inspections to the installation to make sure that all hardware is secure and tight.

In order to protect your bars/boards, please use mild soap/non-abrasive products for cleaning only.

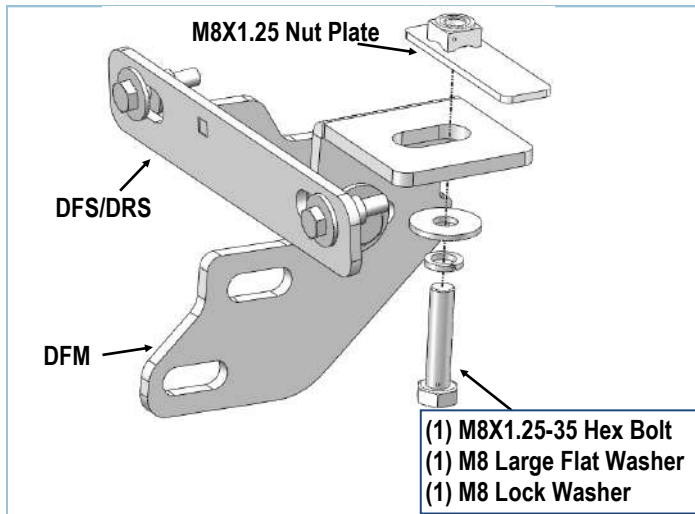

(Fig 11) Driver Front Mounting Bracket Installation  
(Vehicles with open mounting location)

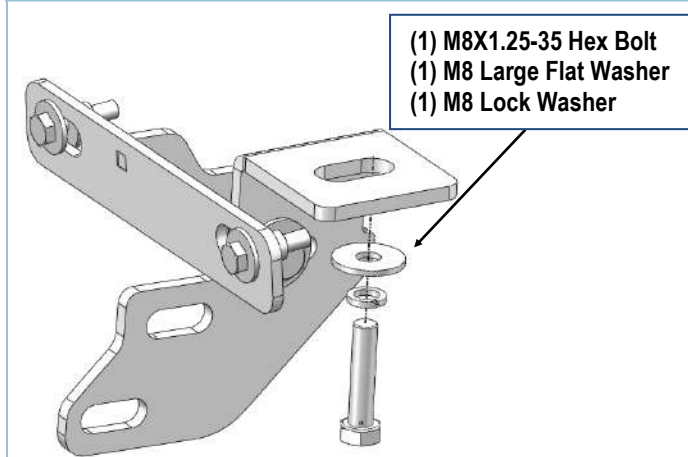

(Fig12) Driver Front Mounting Bracket Installation  
(Vehicles with factory threaded hole in floor panel)

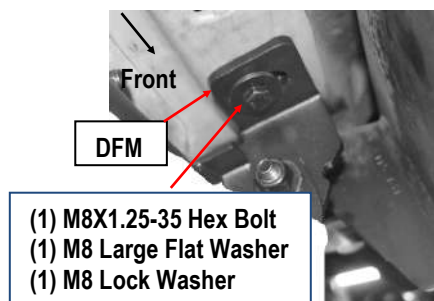

(Fig13) Driver Front Mounting Bracket Installed



# iArmor®

