

iArmor®

IARMOR EDGE™

PART#: IA-N230

BEFORE INSTALLATION

REMOVE CONTENTS FROM BOX. VERIFY ALL PARTS ARE PRESENT. READ INSTRUCTIONS CAREFULLY BEFORE STARTING INSTALLATION. ASSISTANCE IS RECOMMENDED. THANK YOU FOR CHOOSING OUR PRODUCT!

***DRILLING NOT REQUIRED**

***TRIMMING NOT REQUIRED**

Fastener Size	Tightening Torque (ft-lbs)	Required
6mm	6-7	√
8mm	16-18	√
10mm	31-32	X
12mm	56-58	X
14mm	92-94	X



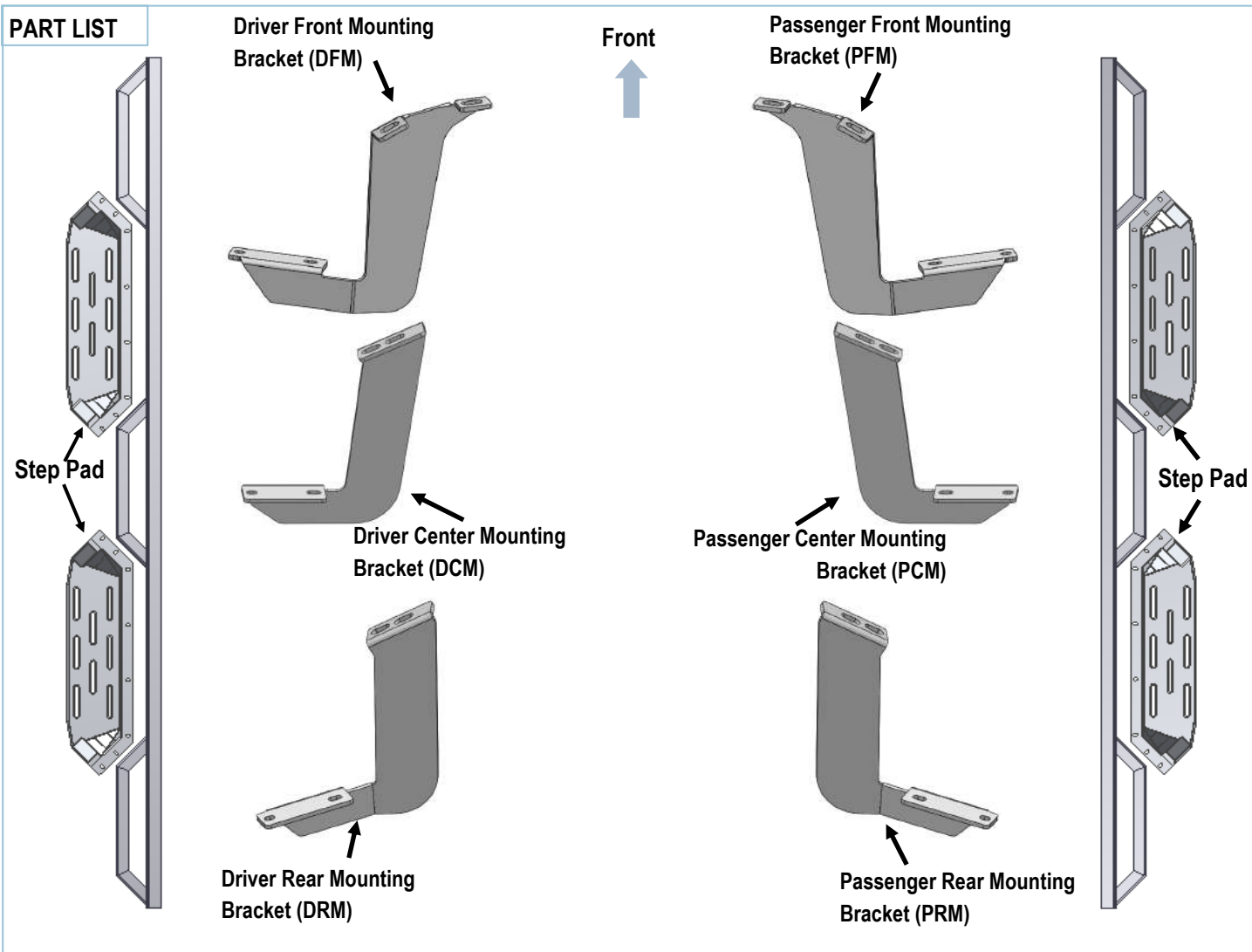



PART LIST



Customer Support: info@iarmorauto.com

iArmor[®]

Hardware Package					
Item	QTY	Description	Item	QTY	Description
1#	12	M8X1.25-30mm Hex Bolts	4#	44	M6X1-20mm T-Bolts
2#	12	M8 Flat Washers	5#	44	M6 Large Flat Washers
3#	12	M8 Lock Washers	6#	44	M6X1 Nylon Lock Nuts

					
1#	2#	3#	4#	5#	6#

iArmor®

The instruction here is for your reference only. We strongly recommend the professional installer for best result. We are not responsible for any damage caused by the installation.

STEP 1

Install the Step Pads onto the step bars with (32) M6x1-20mm T-Bolts, (32) M6 Flat Washers and (32) M6 Nylon Lock Nuts.

IMPORTANT: Don't hit the step pad with any metal hammer within step pad installation, or the step pad will be damaged.

- (8) M6X1-20mm T-Bolts
- (8) M6 Large Flat Washers
- (8) M6X1 Nylon Lock Nuts

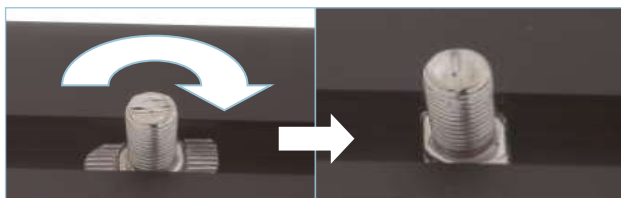

Note: Rotate 90° after inserting the T-Bolts into the

Attach the Passenger Front Mounting Bracket on the factory rocker panel bracket, line up to the (2) mounting threaded holes and secure by using the included (2) M8X1.25-30mm Hex Bolts, (2) M8 Lock Washers and (2) M8 Flat Washers, (Fig 2). Do not fully tighten hardware at this time.

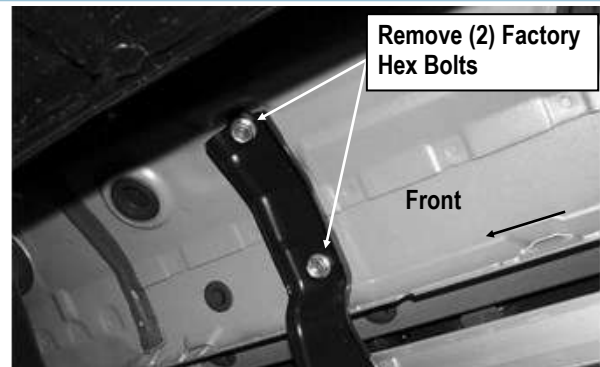

(Fig 1) Passenger Side Front Mounting Location

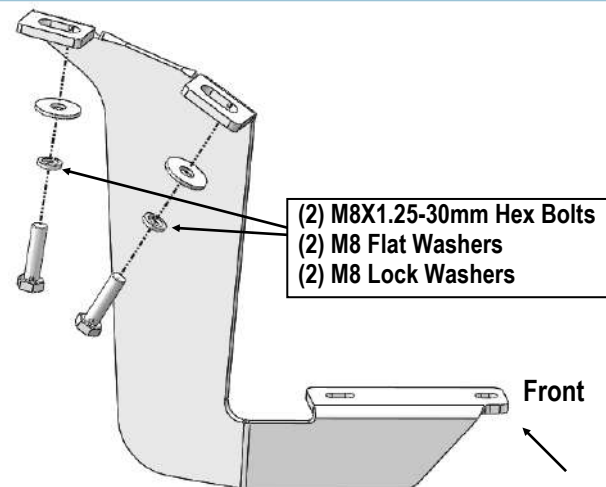

(Fig 2) Passenger Front Mounting Bracket Installation

STEP 2

Start installation on the passenger side of the vehicle, remove the existing (2) factory bolts located by the front tire opening securing the factory rocker panel bracket to the vehicle, (Fig1).

STEP 3

Move to the Passenger Side Center Mounting Location, (Fig 3). Repeat **Step 2** to install the Passenger Center Mounting Bracket, (Fig 4). Do not fully tighten hardware at this time.

iArmor®

Remove (2) Factory Hex Bolts



(Fig 3) Passenger Side Center Mounting Location

Remove (2) Factory Hex Bolts



(Fig 5) Passenger Side Rear Mounting Location

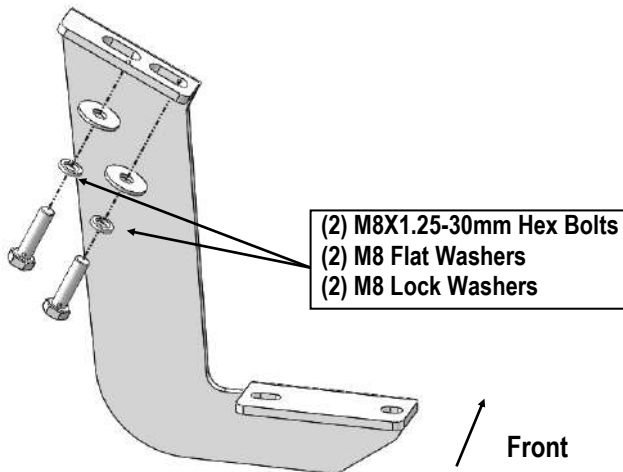

(Fig 4) Passenger Center Mounting Bracket Installation

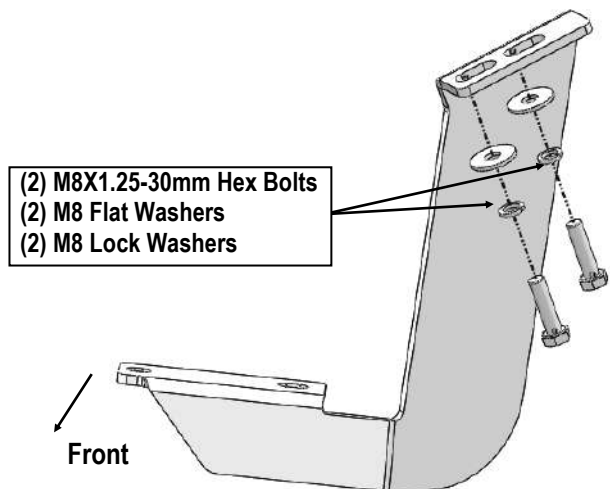

(Fig 6) Passenger Rear Mounting Bracket Installation

STEP 4

Move to the Passenger Side Rear Mounting Location. Repeat **Step 2** to install the Passenger Rear Mounting Bracket with (2) M8X1.25-30mm Hex Bolts, (2) M8 Lock Washers and (2) M8 Flat Washers, (**Figs 5&6**) . Do not fully tighten hardware at this time.

STEP 5

Once all (3) mounting brackets have been installed, attach the assembled passenger step bar onto the brackets with (6) M6X1 -20mm T-Bolts, (6) M6 Flat Washers and (6) M6X1 Nylon Lock Nuts, (**Fig 7**) . Do not fully tighten hardware at this time.

iArmor[®]

STEP 6

Properly level and adjust the Step Bar and fully tighten all hardware.

STEP 7

Move to the Driver side of the vehicle. Repeat **Steps 2-6** for the Driver Side Step Bar installation.

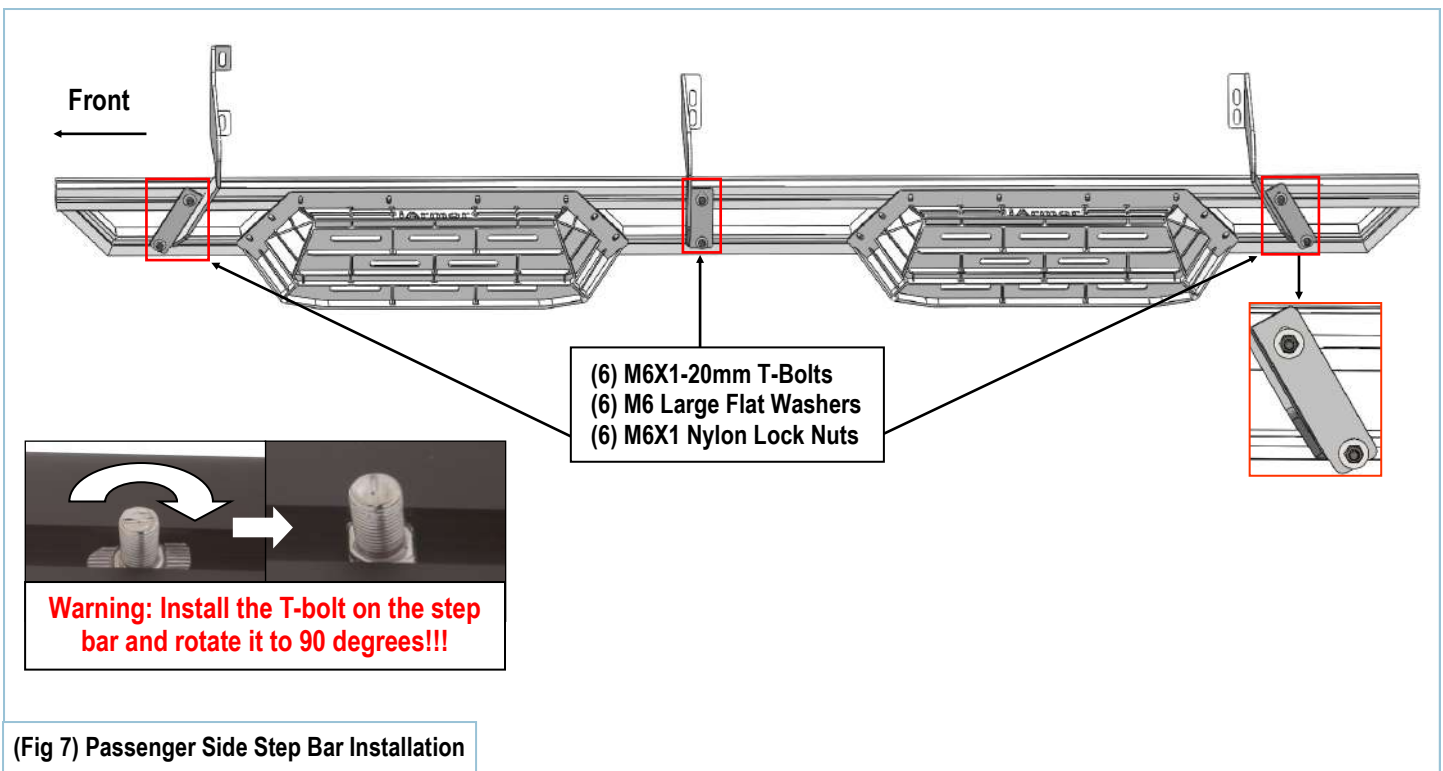

Attention

Do periodic inspections to the installation to make sure that all hardware is secure and tight.
In order to protect your bars/boards, please use only mild soap/non-abrasive products for cleaning.