

# iBoard®

## iBoard® by APS

PART#: IB-014

READ INSTRUCTIONS CAREFULLY BEFORE STARTING INSTALLATION. REMOVE CONTENTS FROM BOX AND VERIFY ALL PARTS ARE PRESENT. ASSISTANCE IS RECOMMENDED.

\*BODY FRAME MOUNT  
\*DRILLING IS REQUIRED

Fastener Size	Tightening Torque (ft-lbs)	Required
6mm	6-7	√
8mm	16-18	X
10mm	31-32	√
12mm	56-58	√
14mm	92-94	X

### PART LIST

Front  
↑



Driver Front Mounting Bracket (DFM)

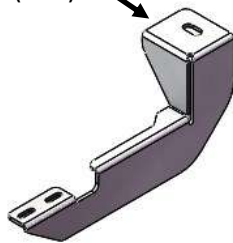

Passenger Front Mounting Bracket (PFM)

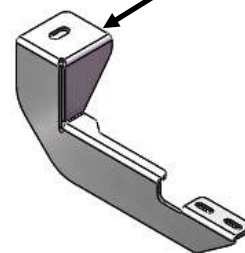

Driver/Passenger Rear Support Bracket (DRS/PRS)

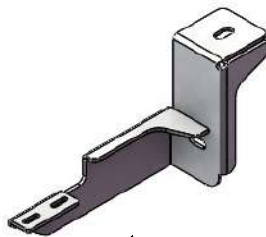

Driver Rear Mounting Bracket (DRM)

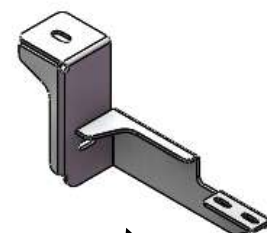

Passenger Rear Mounting Bracket (PRM)



Customer Support: [info@iboardauto.com](mailto:info@iboardauto.com)

# iBoard®

## Hardware Package A (For Bracket Installation)



X4

M12X1.75-120mm Hex Bolt



X4

M12 Large Flat Washer



X4

M12 Lock Washer



X4

M10X1.5-  
35mm Hex Bolt



X8

M10 Large Flat Washer



X4

M10 Lock Washer



X4

M10 Hex Nut

## Hardware Package B (For Aluminum Step Bar Installation Only, Not Supply to Stainless Steel Step Bar)



X8

M6X1-20mm Square Head Bolt



X8

M6 Large Flat Washer



X8

M6 Nylon Lock Nut

## Hardware Package C (For Stainless Steel Step Bar Installation Only, Not Supply to Aluminum Step Bar)



X8

M6X1-20mm Hex Bolt



X8

M6 Lock Washer



X8

M6 Flat Washer

**IMPORTANT ALERT:** GM uses a very strong thread-locking compound on all body bolts. Use of an air assisted impact ratchet can cause damage to the threads on factory body mount bolts and the internal nut assembly because of this thread locking compound. We only recommend the use of hand tools to slowly remove and reinstall body mount bolts on all GM vehicles.

**CRITICAL INFORMATION:** If during the removal process, it becomes increasingly difficult to unscrew the body mount bolt with hand tools, tighten the bolt several rotations to clear the thread locking compound from the threads, then reverse direction and continue to unscrew until the body mount bolt is out. Repeat this process as necessary on all GM body mount bolts. Use of an appropriate anti-seize compound is highly recommended for re-installation. Tighten body mount bolt to factory torque specifications for your particular model year.

# iBoard®

## STEP 1

Start installation from the driver side front of the vehicle. Remove the factory body mount bolt.

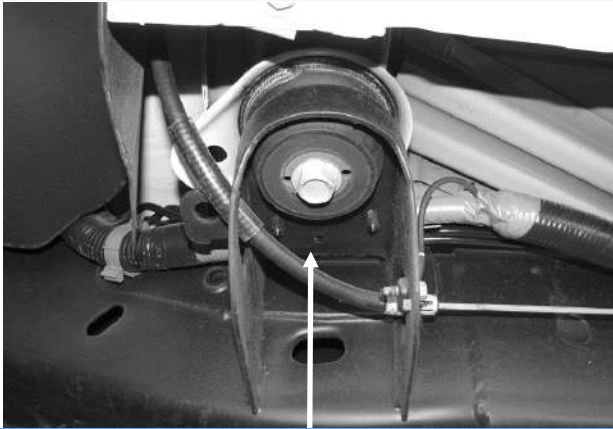

(Fig 1) Example Of Gm Factory Body Mount Bolt

## STEP 2

Attach the Driver Front Mounting Bracket (DFM) to the front body mount with (1) M12X1.75-120mm Hex Bolt, (1) M12 Lock Washer and (1) M12 Large Flat Washer, (Fig 2). Do not fully tighten hardware at this time.

**IMPORTANT!** To prevent unnecessary noise, adjust the position of all Mounting Brackets, make sure the Mounting Brackets no contact with the factory steel body mount bracket or emergency brake cables.

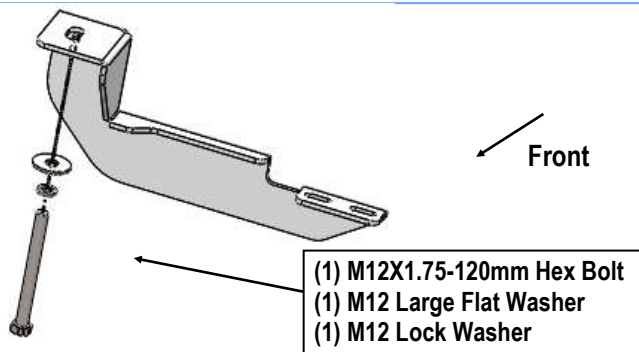

(Fig 2) Driver Front Mounting Bracket Installation

## STEP 3

Move to the rear mounting location. Repeat **Step 2** for the Driver Rear Mounting Bracket installation, (Fig 3). Do not fully tighten hardware at this time.

Select (1) Driver Rear Support Bracket (DRS/PRS). Attach the short end of the Support Bracket to the back of the Driver Rear Mounting Bracket with (1) M10X1.5-35mm Hex Bolt, (2) M10 Large Flat Washers, (1) M10 Lock Washer and (1) M10 Hex Nut, (Fig 3). Do not fully tighten hardware at this time.

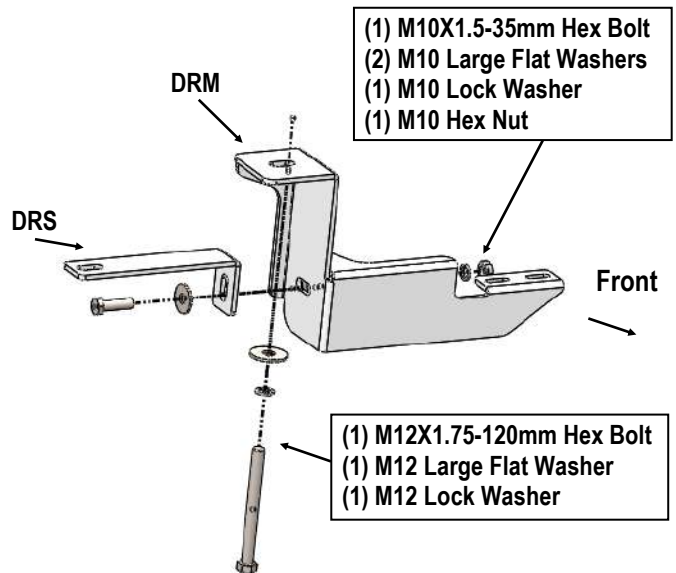

(Fig 3) Driver Rear Bracket Installation

## STEP 4

Once all (2) mounting brackets are installed, then proceed to the Step Bar installation. According to the style of Step Bar proceed to the correct installation STEPS.

**Note:** Aluminum Step Bar refer to STEP 5; Stainless Steel Step Bar skip to STEP 6.

# iBoard®

## STEP 5

### Aluminum Step Bar Installation:

Select a **Aluminum Step Bar**. Slip (2) M6x1-20mm Square Head Bolts into each bottom channel (**Fig 4**). Carefully position the Step Bar onto the (2) Mounting Brackets.

**IMPORTANT:** Do not slide the Step Bar on the Brackets or the bottom surface of the board will be damaged. Attach the Step Bar to each Mounting Brackets with (2) M6x1-20mm Square Head Bolts, (2) M6 Large Flat Washers and (2) M6 Nylon Lock Nuts, (**Fig 5**). Do not fully tighten at this time.

Level and adjust the Step Bar and fully tighten all hardware.

Move to **Step 7**.



(Fig 4) Slip M6X1-20mm Square Head Bolts Into The Bottom Channels

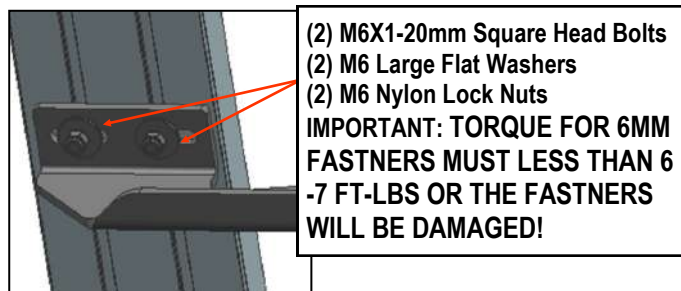

(Fig 5) Running Board Installed Onto Mounting Bracket

## STEP 6

### Stainless Steel Step Bar Installation:

Select a **Stainless Steel Step Bar** (with the U-Sliders installed on the Bar). Loose the U-Sliders, reposition the U-Sliders onto the board according to the (2) Installed Mounting Brackets location, (**Fig 6**). Re-secure the U-Sliders on the Step Bar. Attach the Step Bar to the installed Mounting Brackets with (4) M6X1-20mm Hex Bolts, (4) M6 Large Flat Washers & (4) M6 Lock Washers, (**Fig 7**). Do not fully tighten hardware at this time.

Level and adjust the Step Bar and fully tighten all hardware.

Move to **Step 7**.



(Fig 6) Slide & line up the U-Slider with the installed mounting brackets along bottom channel

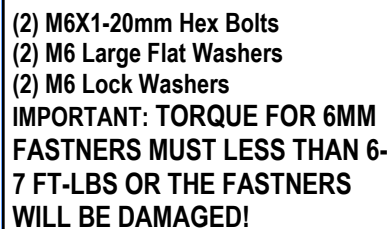

(Fig 7) Step Bar Installed on Bracket Installed (Example)

# iBoard®

## STEP 7

Using the hole in the long end of the Support Bracket as a guide, drill a 7/16" hole in the bottom of the frame. Do not drill close to the edge of the frame. **IMPORTANT!** Any cutting or drilling tool may break or shatter. Government regulations require safety glasses & equipment at all times when cutting or drilling.

Then, attach the Driver Rear Support Bracket (**DRS/PRS**) to the frame with (1) M10X1.5-35mm Hex Bolt, (2) M10 Large Flat Washers, (1) M10 Lock Washer and (1) M10 Hex Nut, (**Fig 8**). Do not fully tighten hardware at this time.

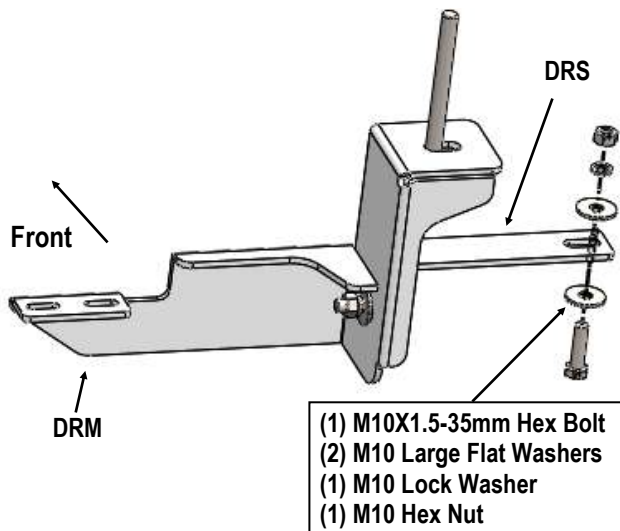

(Fig 8) Driver Rear Support Bracket Installation

## STEP 8

Level and adjust the Running Board and fully tighten all hardware.

**Note:** Check all mounting locations for clearance between factory steel body mount brackets and Mounting Brackets. Once satisfied with fit, fully tighten all hardware.

## STEP 9

Repeat **Steps 1-8** for other side Running Board installation.  
**The installation is completed.**

### Attention

Do periodic inspections to the installation to make sure that all hardware is secure and tight.

In order to protect your bars/boards, please use only mild soap/non-abrasive products for cleaning.