

iBoard®



Scan for
Installation Video

iBoard® by APS

PART#: IB-R400

READ INSTRUCTIONS CAREFULLY BEFORE STARTING INSTALLATION. REMOVE CONTENTS FROM BOX AND VERIFY ALL PARTS ARE PRESENT. ASSISTANCE IS RECOMMENDED.

*ROCKER PANEL MOUNT
*DRILLING IS REQUIRED

Fastener Size	Tightening Torque (ft-lbs)	Required
6mm	6-7	√
8mm	16-18	√
10mm	31-32	√
12mm	56-58	X
14mm	92-94	X

PART LIST

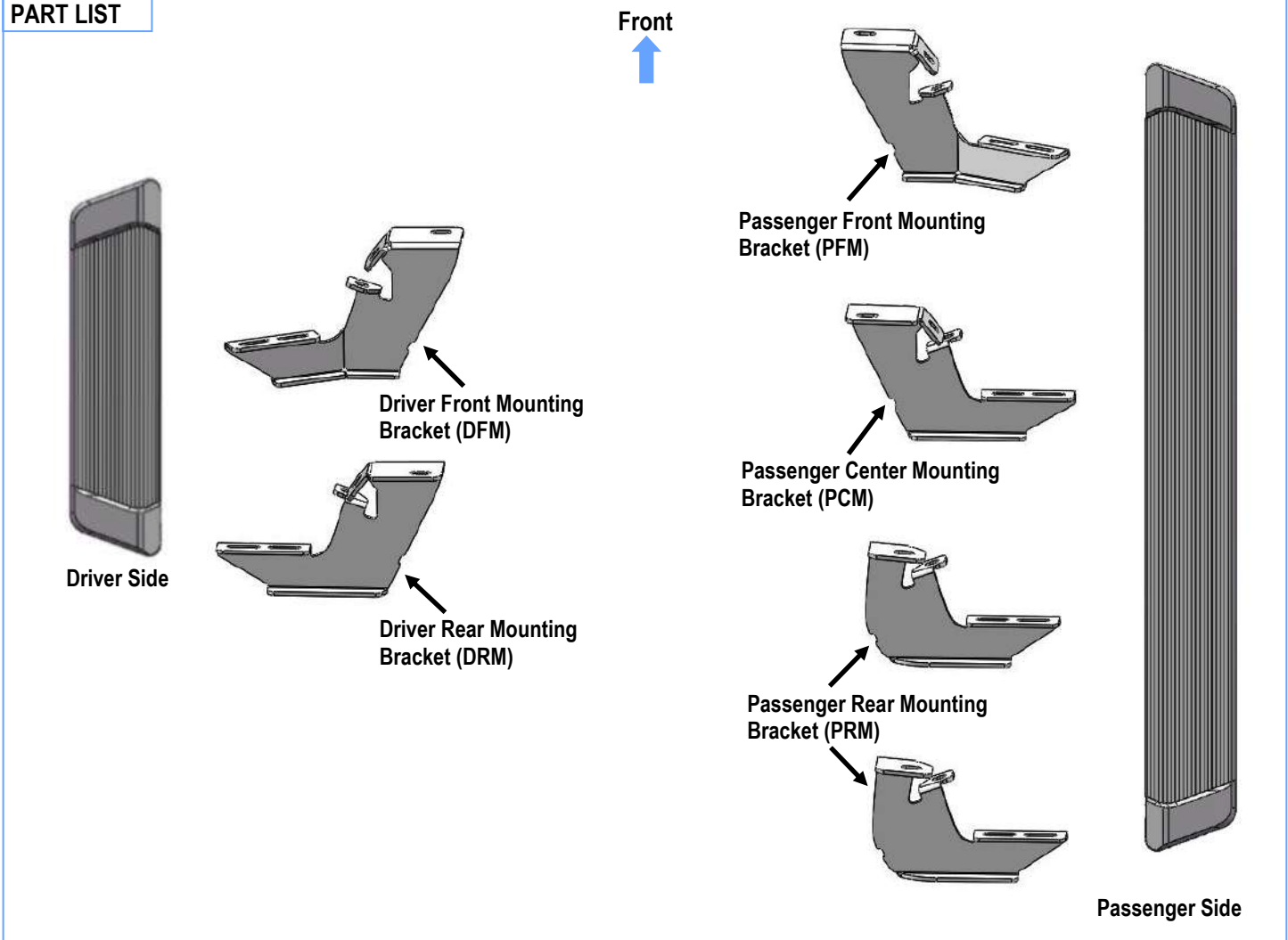

Customer Support: info@iboardauto.com



Hardware Package A (For Bracket Installation)

Item	QTY	Description	Item	QTY	Description
1#	8	M10X40 Bolt Plates	5#	8	M10X1.5 Hex Nuts
2#	8	M10 Plastic Washers	6#	6	M8X1.25-30 Hex Bolts
3#	8	M10 Large Flat Washers	7#	12	M8 Flat Washers
4#	8	M10 Lock Washers	8#	6	M8 Nylon Lock Nuts



1#



2#



3#



4#



5#



6#



7#



8#

Hardware Package B (For Step Bar Installation)

Item	QTY	Description	Item	QTY	Description
1#	12	M6X1-20mm Square Head Bolts	3#	12	M6 Nylon Lock Nuts
2#	12	M6 Large Flat Washers			



1#



2#



3#



STEP 1

Starting installation from the driver side front of the vehicle. Locate and remove (1) rubber plug closest to the front tire opening, (Fig 1). Select (1) M10 Bolt Plate and (1) M10 Plastic Washer. Partially thread the M10 Plastic Washer onto the M10 Bolt Plate. Insert the M10 Bolt Plate into the opening and thread the M10 Plastic Washer down tight, (Fig 2).

NOTE: The M10 Plastic Washer is designed to hold the M10 Bolt Plate in place during Bracket installation.

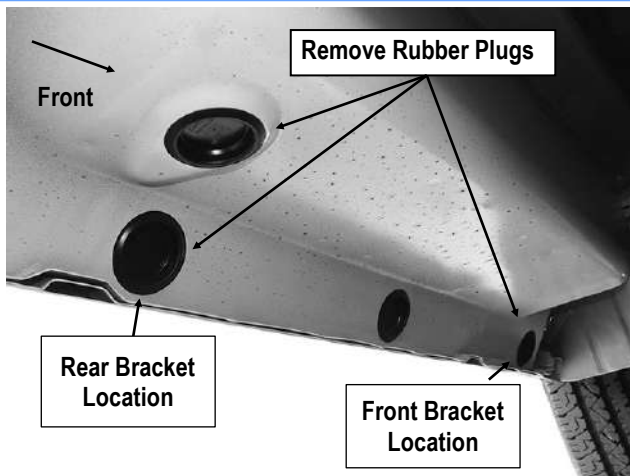

(Fig 1) Driver Side Mounting Bracket Locations

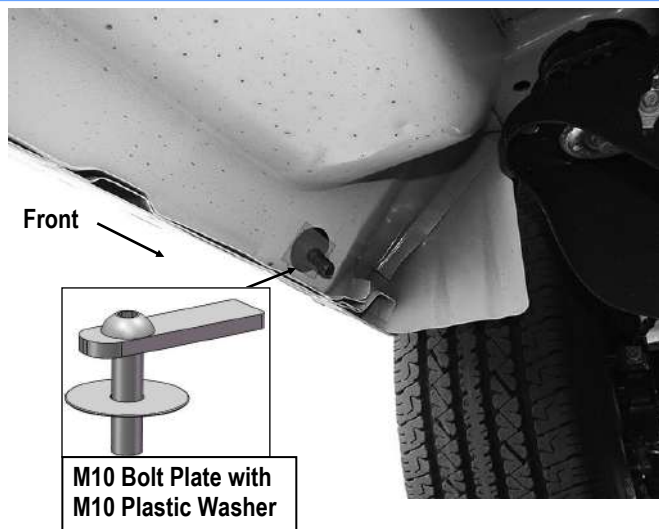

(Fig 2) M10 Bolt Plate Installed
(On Driver Side Front Mounting Location)

STEP 2

Select the Driver Front Mounting Bracket (DFM). Attach the Bracket to the installed M10 Bolt Plate with (1) M10 Large Flat Washer, (1) M10 Lock Washer and (1) M10 Hex Nut, (Fig 3 & 4). Do not fully tighten the hardware at this time.

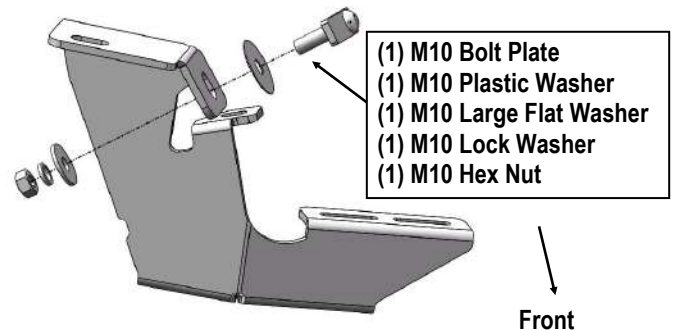

(Fig 3) Driver Front Mounting Bracket Installation

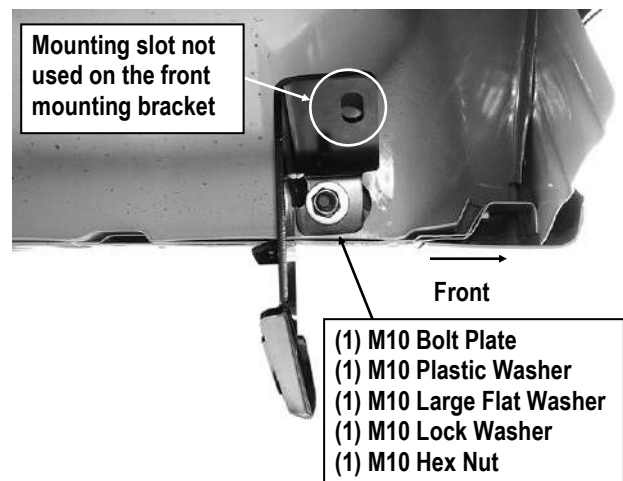

(Fig 4) Driver Front Mounting Bracket Installation



STEP 3

Move to the driver side rear mounting location of the vehicle, (**Fig 1**). Locate and remove the (2) rubber plugs. Insert (2) M10 Bolt Plates into the openings with M10 Plastic Washers holding.

Repeat **Step 2** to attach the Driver Rear Mounting Bracket (**DRM**) to the installed (2) M10 Bolt Plates, (**Fig 5**). Do not fully tighten hardware at this time.

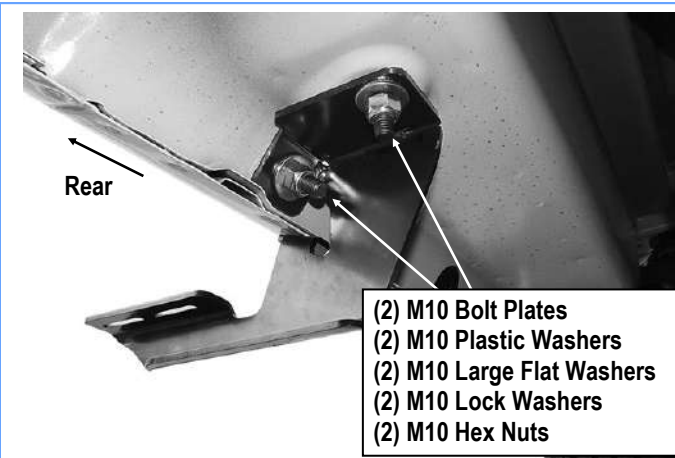

(Fig 5) Driver Rear Mounting Bracket Installation

STEP 4

Once all (2) mounting brackets are installed. Select the Driver Side Running Board. Slip (2) M6X1-20mm Square Head Bolts into each bottom channel (**Fig 6**). Carefully position the Running Board onto the (2) Mounting Brackets. Attach the Running Board to each Mounting Bracket with (2) M6X1-20mm Square Head Bolts, (2) M6 Large Flat Washers and (2) M6 Nylon Lock Nuts (**Fig 7**). Do not fully tighten at this time.

IMPORTANT: Do not slide the Running Board on the Brackets or the bottom surface of the board will be damaged.

M6X1-20mm Square Head Bolts

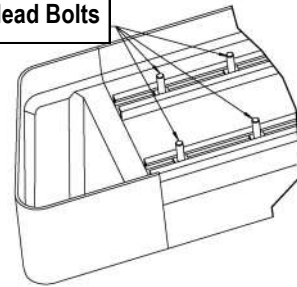

(Fig 6) Slip M6X1-20mm Square Head Bolts Into The Bottom Channels

(2) M6X1-20mm Square Head Bolts
(2) M6 Large Flat Washers
(2) M6 Nylon Lock Nuts

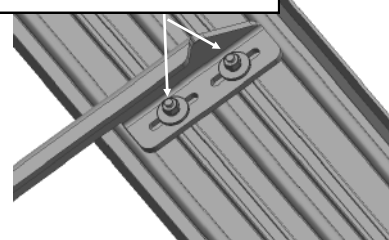

(Fig 7) Running Board Installed Onto Mounting Bracket

STEP 5

Level and adjust the Running Board and fully tighten all hardware.

Push the Mounting Brackets up tight against the bottom of the body. Use the mounting tab on each Bracket for a guide, mark and drill a 5/16" hole through the pinch weld for both Brackets, (**Fig 8**).

NOTE 1: Do not drill too close to the edge of the pinch weld, adjust Bracket position as required before drilling through pinch weld.

NOTE 2: It may be necessary to remove Running Board and Brackets to drill the required holes through the pinch weld. Repeat **Steps 2—4** to reinstall the brackets and Running Board.

IMPORTANT! Any cutting or drilling tool may break or shatter. Government regulations require safety glasses & equipment at all times when cutting or drilling.

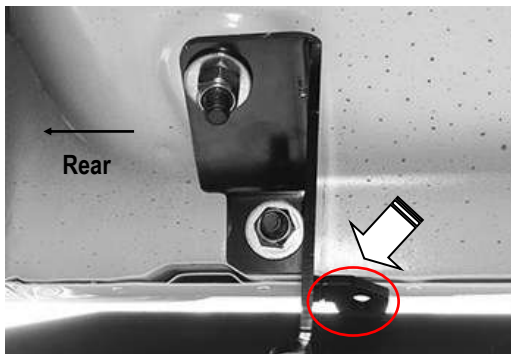

(Fig 8) Drill a 5/16" Hole Through Pinch Weld
Do Not Drill Too Close To Edge Of Pinch Weld
(Driver Side Rear Bracket Pictured)

STEP 6

Once both holes have been drilled on the pinch weld, attach the mounting tabs on the (2) Driver Side Mounting Brackets to the pinch weld with (2) M8X1.25-30mm Hex Bolts, (4) M8 Flat Washers and (2) M8 Nylon Lock Nuts, (Figs 9 & 10). Fully tighten hardware at this time.

- (1) M8X1.25-30mm Hex Bolt
- (2) M8 Flat Washers
- (1) M8 Nylon Lock Nut

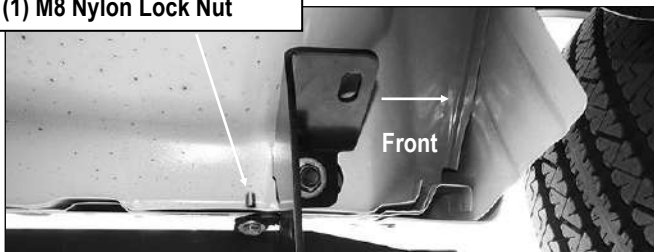

(Fig 9) Attach Driver Front Mounting Bracket To Pinch Weld

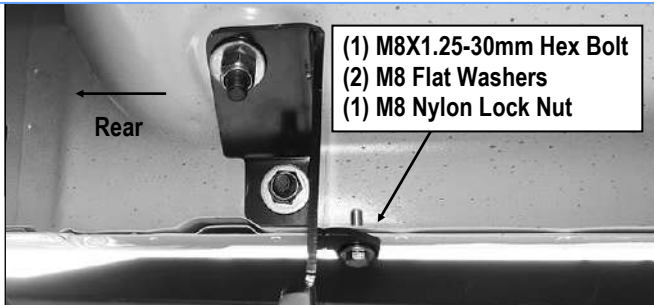

(Fig 10) Attach Driver Rear Mounting Bracket To Pinch Weld

- (1) M8X1.25-30mm Hex Bolt
- (2) M8 Flat Washers
- (1) M8 Nylon Lock Nut

STEP 7

Move to the passenger side front of the vehicle. Locate the rubber plug closest to the front tire opening, (Fig 11). Repeat Steps 1 & 2 to install the Passenger Front Mounting Bracket (PFM), (Fig 12).

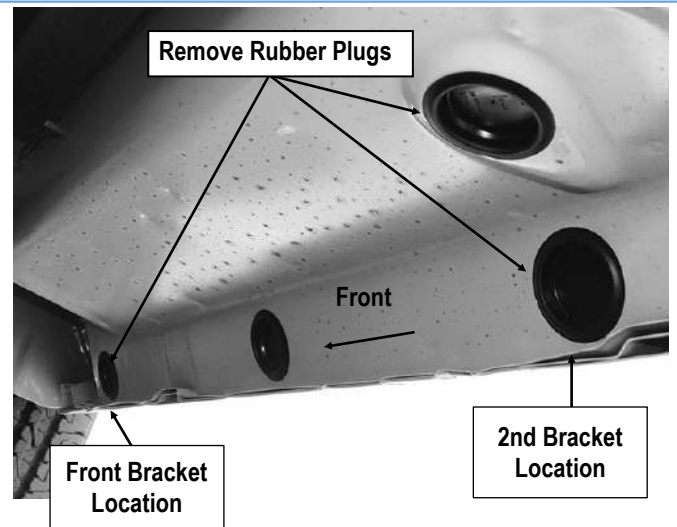

(Fig 11) Passenger Side Front & 2nd Mounting Locations

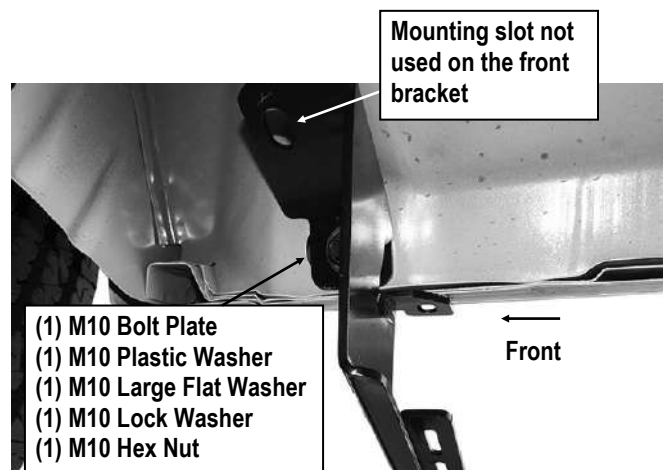

- (1) M10 Bolt Plate
- (1) M10 Plastic Washer
- (1) M10 Large Flat Washer
- (1) M10 Lock Washer
- (1) M10 Hex Nut

(Fig 12) Passenger Front Mounting Bracket Installation



STEP 8

Move to the Passenger side 2nd mounting location. Remove (2) rubber plugs, (Fig 11). Repeat **Steps 1–3** to install the Passenger Center Mounting Bracket (PCM), (Fig 13).

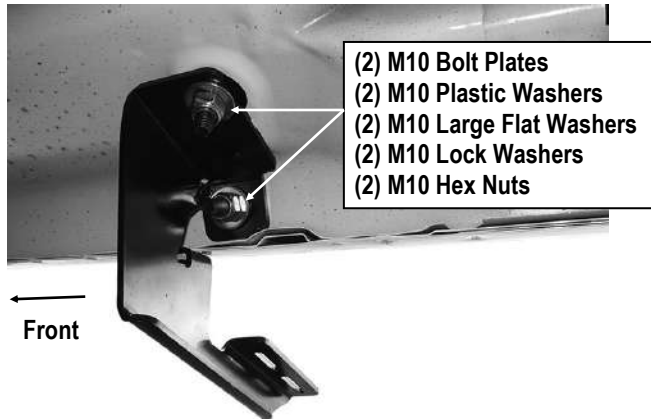

(Fig 13) Passenger Center Mounting Bracket Installation

STEP 9

Move to the Passenger Side 3rd & Rear Mounting location, (Fig 14). Locate and remove the rubber plugs on the body panel. Select (2) Passenger Rear Mounting Brackets (PRM). Repeat **Steps 1-2** to attach the Passenger Rear Mounting Brackets to the installed M10 Bolt Plate, (Fig 15).

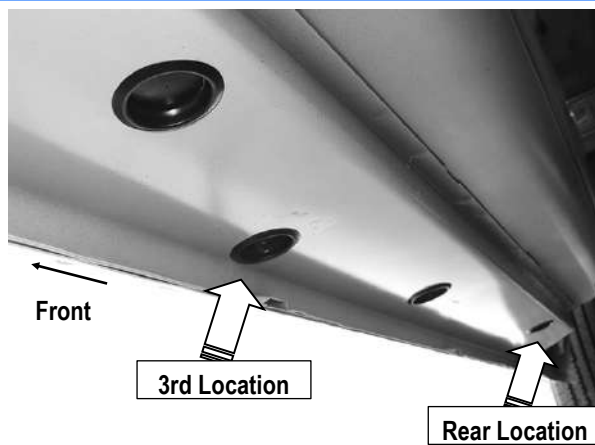

(Fig 14) Passenger Side 3rd & Rear Mounting Location

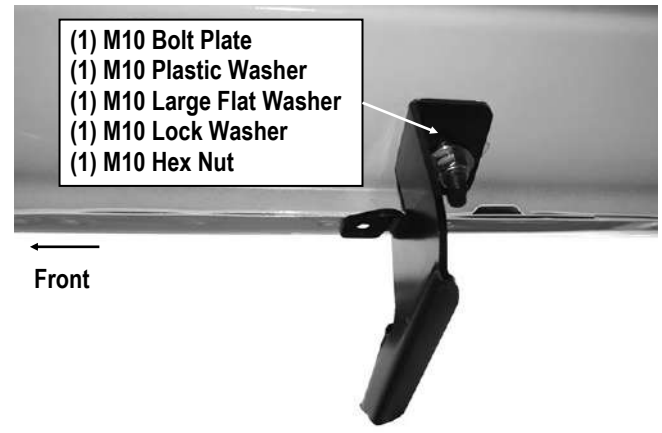

(Fig 15) Passenger 3rd Mounting Bracket Installation

STEP 10

Select the Passenger Side Running Board. Slip (4) M6x1-20mm Square Head Bolts into each bottom channel (Fig 6). Repeat **Step 4** to attach the Running Board to (4) Mounting Brackets. Do not fully tighten hardware at this time.

STEP 11

Repeat **Steps 4–6** to drill and attach the (4) Mounting Brackets to the pinch weld, (Figs 16–18).

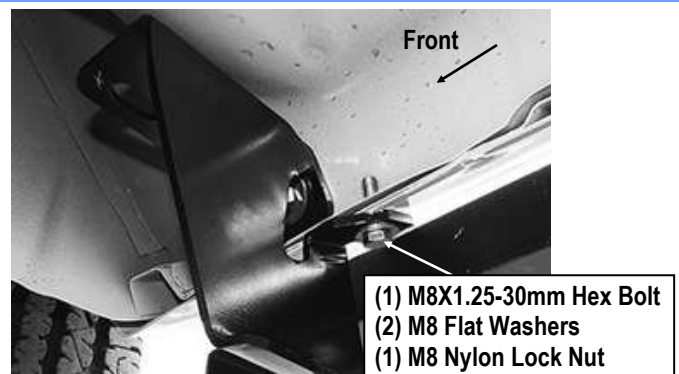

(Fig 16) Passenger Front Mounting Bracket Attached to the Pinch Weld



STEP 12

Level and adjust the Running Board and fully tighten all hardware. The installation is completed.

Attention

Do periodic inspections to the installation to make sure that all hardware is secure and tight.

In order to protect your bars/boards, please use mild soap/non-abrasive products for cleaning only.

- (1) M8X1.25-30mm Hex Bolt
- (2) M8 Flat Washers
- (1) M8 Nylon Lock Nut



(Fig 17) Passenger 2nd Mounting Bracket Attached to the Pinch Weld

- (2) M8X1.25-30mm Hex Bolts
- (4) M8 Flat Washers
- (2) M8 Nylon Lock Nuts

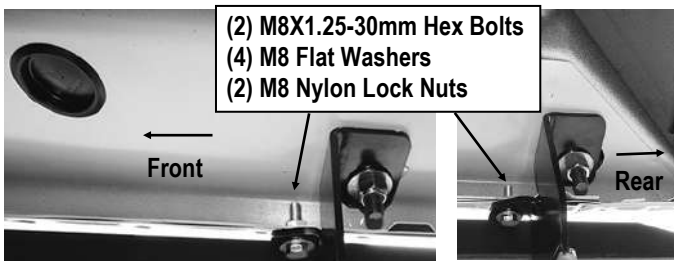

(Fig 18) Passenger 3rd & Rear Mounting Bracket Attached to the Pinch Weld