

For 2007-2018 Chevy/GMC Silverado/Sierra 1500 Crew Cab/ Extended Cab/Double Cab / 6.5ft Bed/
 2007-2019 Chevy/GMC Silverado/Sierra 2500/3500 Crew Cab/ Extended Cab/Double Cab / 6.5ft Bed/
 (Incl. Diesel Models With DEF Tanks)(Excludes 07 Classic Models)(Incl. 2019 Silverado 1500 LD)
 Rev:20190201

PARTS LIST:

Item	QTY	Description	Item	QTY	Description
#1	2	Running Board(use for left or right)	#15	12	M8 x1.25- 25mm Hex Bolts
#2	1	Passenger/right Front Bracket (PFM)	#16	3	M8 x1.25- 35mm Hex Bolt
#3	5	Mounting Brackets	#17	15	M8 Flat Washers
#4	5	Mounting Plates	#18	15	M8 Lock Washers
#5	1	Driver Rear Isolator Bracket(DRS)	#19	11	M8 Clip-on Nuts
#6	1	Passenger Rear Isolator Bracket(PRS)	#20	4	M12 Lock Washers
#7	1	Driver Rear Lower Bracket(DRM)	#21	2	M12 x1.75 - 60mm Hex Bolts
#8	1	Passenger Rear Lower Bracket(PRM)	#22	4	M12 Flat Washers
#9	2	Sleeve Washers	#23	2	M12 Hex Nuts
#10	2	M12X35 Bolt Plate	#24	10	M8X1.25-20 Inner Hex Bolts
#11	4	M12 Large Flat Washers	#25	10	M8X1.25 Hex Flange Nuts
#12	2	12mm Plastic Washers	#26	20	M6-1.0mm x 20mm T-Bolts
#13	1	25X30X3mm SQ Spacer	#27	20	6mm x 22mm x 2mm Flat Washers
#14	1	M8X1.25 Nylon Lock Nuts	#28	20	M6 Nylon Lock Nuts

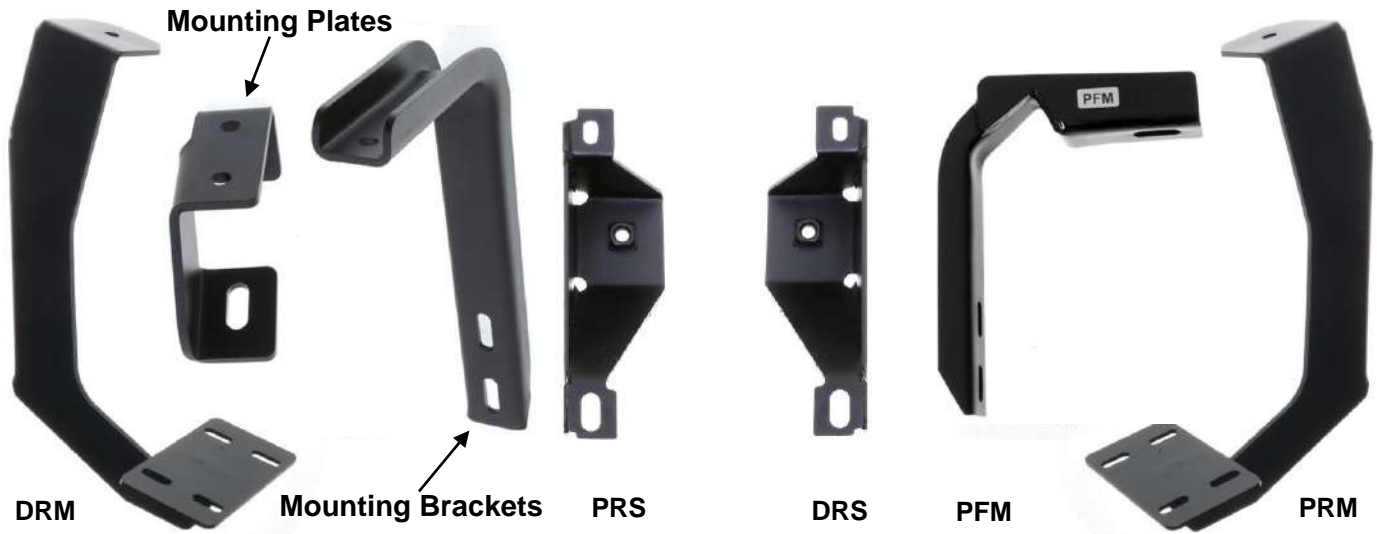

IMPORTANT ALERT: FOR WHEEL TO WHEEL APPLICATION, WEIGHT TO THE REAR END AREA OF THE RUNNING BOARD BEHIDE THE LAST BRACKET NEED TO LESS THEN 130KG.OVERWEIGHT IN THIS AREA MAYBE DAMAGE YOUR RUNNING BOARD.

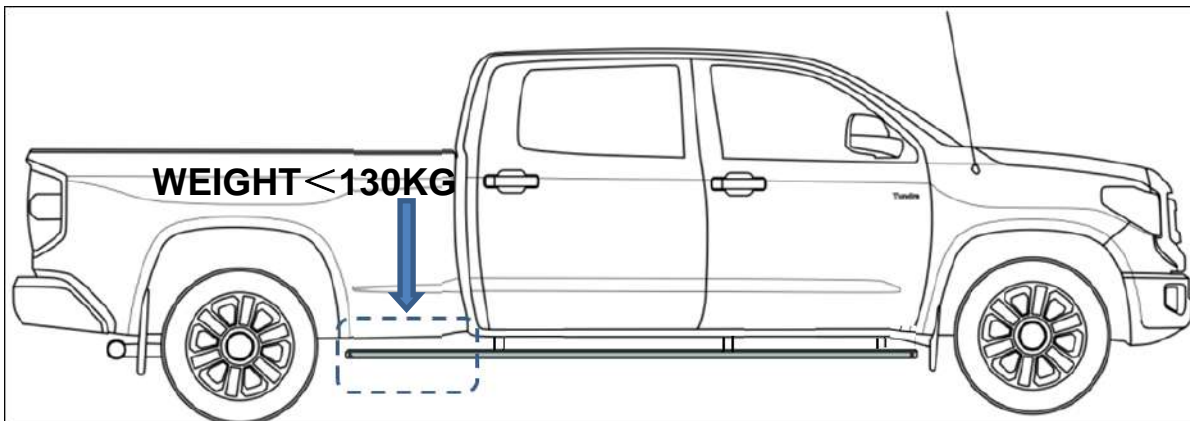

PROCEDURE:

REMOVE CONTENTS FROM BOX. VERIFY ALL PARTS ARE PRESENT. READ INSTRUCTIONS CAREFULLY BEFORE STARTING INSTALLATION. ASSISTANCE IS RECOMMENDED. ON MODELS WITH DEF TANK, SELECT A FLAT, LEVEL AREA FOR INSTALLATION.

1. Start the installation under the driver side of the vehicle. Locate the 4 tabs along the bottom edge of the body, (pinch weld). Mounting Brackets will bolt to the 1st, 2nd, (just in front of center of cab), and 4th mounting tabs, **(Figure 1)**. Directly above each tab is a top mounting location on the side of the body panel. Hold a Bracket up in place to help determine the mounting holes to use along the body.
2. Determine the correct procedure for your model year and each Bracket location.

Bottom mounting location on the edge of the pinch weld.

Flat tab on pinch weld with factory installed weld nut:

Thread hex bolt into weld nut from the backside-down to clear paint from threads, **(Figure 2)**.

Flat tab on pinch weld with hole:

Select (1) 8mm Clip Nut. Slide the Clip Nut over the tab with the nut facing up behind the tab, **(Figures 3—5)**. Line up threaded nut with hole in tab. Repeat for each mounting location.

Top mounting location on the side of the body panel.

Models with factory installed threaded insert in body panel:

Thread 8mm Hex Bolt into threaded insert to clear paint as required, **(Figures 2 & 3)**.

Large and small hole in side of body panel:

Remove the rubber plug from the larger hole, **(Figure 4)**. Select (1) 8mm Clip Nut. Slide the Clip Nut into the larger hole. Line up the threaded nut with the smaller hole, **(Figure 5)**.

3. Assembled (1) Mounting Bracket and (1) Mounting Plate as shown **(Figures 6)**. **NOTE:** Bolt the Mounting Bracket to the Clip Nuts and/or the factory threaded holes with (2) M8 Hex Bolts, (2) M8 Lock Washers and (2) M8 Flat Washers, **(Figures 7)**. Snug but do not fully tighten the hardware.
4. Repeat **Steps 1—3** to install the (2) remaining driver side Brackets.
5. Move to driver side Wheel to wheel location, directly behind the cab, underneath the bed locate the beam that mounts the bed to the frame. There will be 2 pre-existing bolts. remove both factory M8 and M12 hardware**(Figure 7A)**. Select a driver rear isolator bracket, both to the frame with include (1) M8x35mm Hex Bolt,(1)8mm Lock Washer, (1)8mm Flat Washer, and(1) 12mm x 29mm x 5mm Thick Spacer. Snug but do not fully tighten the hardware.
On 07-17 MY: Re-used M12 factory bolts (Figure 7B).
On 2018 MY: Attach the bracket with (1)12mm Bolt Plate, (1) Plastic Retainer, (1) 12mm x 29mm x 2mm Flat Washer, (1)12mm x 24mm x 2.5mm Flat Washer, (1)12mm Lock Washer and (1) Hex Nut (Figure 7C).
6. Attach the Driver rear lower bracket and Sleeve Washer to the isolator bracket with (1)M12x60mm Hex bolt, (1)12mm Flat Washer and (1)12mm Lock Washer **(Figure 7B)**. Snug but do not fully tighten the hardware.
7. Select the Running Board. Slip (10) M6 T-Bolts into each bottom channel **(Figure 16)**. Carefully position the Running Board onto the (4) Mounting Brackets. **IMPORTANT:** Do not slide the Running Board on the Brackets or damage to the finish may result. Attach the Running Board to the Mounting Brackets with (4) M6 T-bolts,(4)M6 flat washers and (4)M6 nylon lock nuts, **(Figure 17)**. Do not tighten hardware.
8. Level and adjust the Running Board and tighten all hardware. **NOTE: Torque all M6 nylon lock nuts to 7 lb-ft.**
9. Move to the passenger side of the vehicle. On the passenger side, determine if the vehicle is equipped with a plastic diesel exhaust fluid (DEF) tank, **(Figures 8 & 9)**.

Models without DEF tank, skip to Step 10.

Models with DEF tank: The tank sits close to the side of the body. With specialized tools, the passenger front upper and lower Bracket can be installed but room is limited. It may be easier to drop the tank down to access the inner side of the body panel for upper bracket installation. Tank will not need to be removed, only dropped down for access to mounting location. **IMPORTANT:** If tank is full, it will be very heavy and assistance is highly recommended to avoid injury or damage to the vehicle or the tank. It is recommended that installation is performed when the DEF tank is low on fluid before dropping the tank.

- a. On models with plastic lower tray under the tank, remove the (3) hex bolts attaching the tray to the frame, **(Figure 8)**, and remove the tray. and remove tray. **2017-Up 2500/3500 models:** Remove the (4) hex bolts attaching the plastic cover to DEF tank, **(Figure 9A)** and remove the plastic cover, **(Figure 9B)**.
- b. Release the tank filler hose. Release the plug for the sending unit on the top of the tank.

For 2007-2018 Chevy/GMC Silverado/Sierra 1500 Crew Cab/ Extended Cab/Double Cab / 6.5ft Bed/
 2007-2019 Chevy/GMC Silverado/Sierra 2500/3500 Crew Cab/ Extended Cab/Double Cab / 6.5ft Bed/
 (Incl. Diesel Models With DEF Tanks)(Excludes 07 Classic Models)(Incl. 2019 Silverado 1500 LD)
 Rev:20190201

- c. Support the tank with a floor jack. Place a smooth flat surface, (wooden block for example), between the floor jack and the tank to avoid damaging the plastic tank. Do not push up on the tank; only support the weight of the tank with the jack.
 - d. Remove the (2) bolts securing the tank straps to the vehicle, **(Figure 10)**. Tilt the straps to release from the brackets. Slowly lower the tank until the top of the tank is almost visible. Use blocks or stands to support the tank while installing the front Upper and Lower Brackets.
 - e. Proceed to **Step 10**.
10. Attach the passenger Front Bracket to the vehicle: pinch weld and top panel **(Figures 11 & 12)**.
- a. **Models with a weld-nut:** see Figure 11. Leave loose at this time.
 - b. **Models with flat tab and hole:** see Figure 12. Leave loose at this time.
11. Repeat **Steps 1—3** for the (2) remaining passenger side Bracket installations.
- a. **2017-up 2500/3500 DEF tank models:** Locate the 2nd tab bracket location along the bottom edge of the body, (pinch weld), **(Figure 13)**. Hold the DEF cover in place and mark the 2nd Bracket location onto the cover, **(Figure 14)**. Use a sharp knife or hacksaw blade to carefully cut a slot in the plastic cover to clear the 2nd Bracket, **(Figure 15)**. Remove as little plastic as possible.
12. Repeat **Steps 7 & 8** to install the passenger running board, **(Figure 17)**.
13. Once the running board are installed and all hardware fully tightened, reinstall the DEF tank and cover, if equipped, as described in **Step 9**.
14. Do periodic inspections to the installation to make sure that all hardware is secure and tight.

To protect your investment, wax this product after installing. Regular waxing is recommended to add a protective layer over the finish. Do not use any type of polish or wax that may contain abrasives that could damage the finish.

For Polished Finishes: Aluminum polish may be used to polish small scratches and scuffs on the finish. Mild soap may be used also to clean the Running Board.

For Black Finishes: Mild soap may be used to clean the Running Board.

Driver/Left Side Installation Pictured

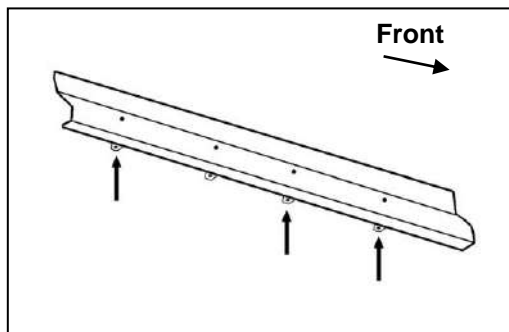

(Fig 1) Back of driver side (3) mounting locations

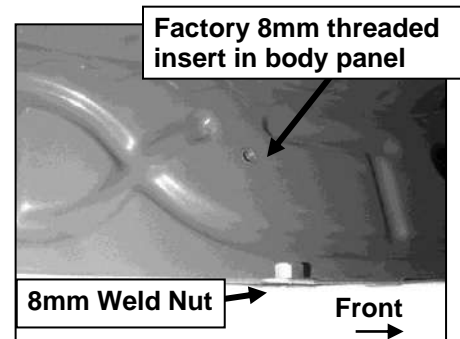

(Fig 2) Passenger side front mounting location

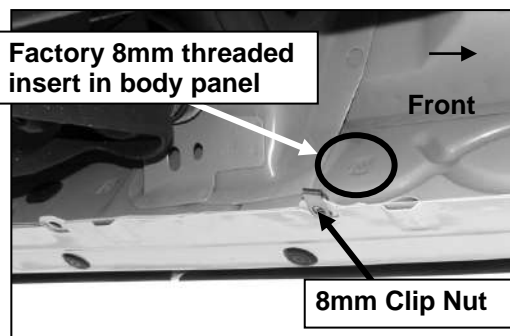

(Fig 3) Driver side 2nd mounting location

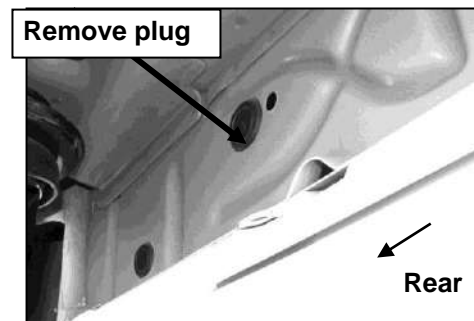

(Fig 4) Driver side 3rd mounting location

For 2007-2018 Chevy/GMC Silverado/Sierra 1500 Crew Cab/ Extended Cab/Double Cab / 6.5ft Bed/
 2007-2019 Chevy/GMC Silverado/Sierra 2500/3500 Crew Cab/ Extended Cab/Double Cab / 6.5ft Bed/
 (Incl. Diesel Models With DEF Tanks)(Excludes 07 Classic Models)(Incl. 2019 Silverado 1500 LD)
 Rev:20190201

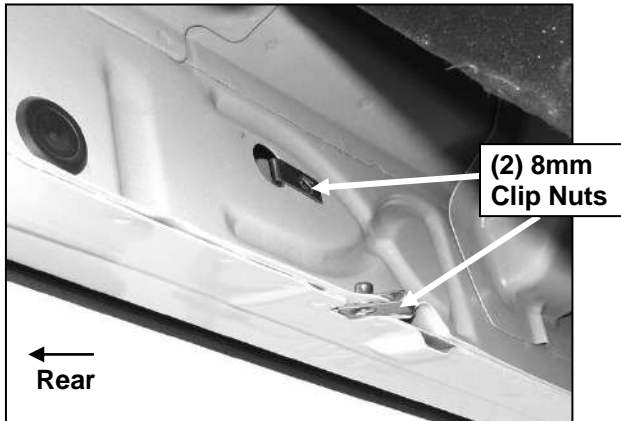

(Fig 5) Driver side 3rd mounting location

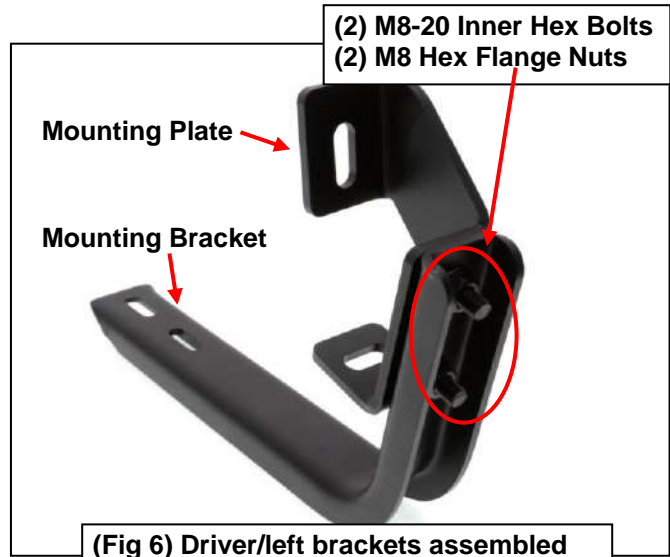

(Fig 6) Driver/left brackets assembled

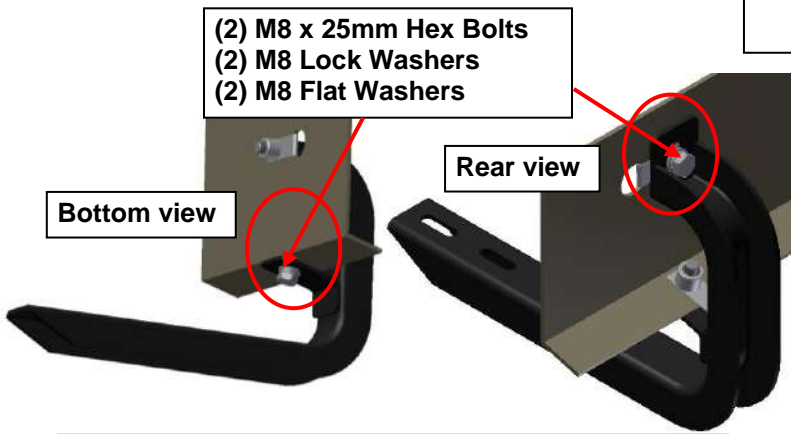

(Fig 7) Driver/left brackets installed(example only)



(Fig 7A) WTW Driver Rear Isolator bracket location

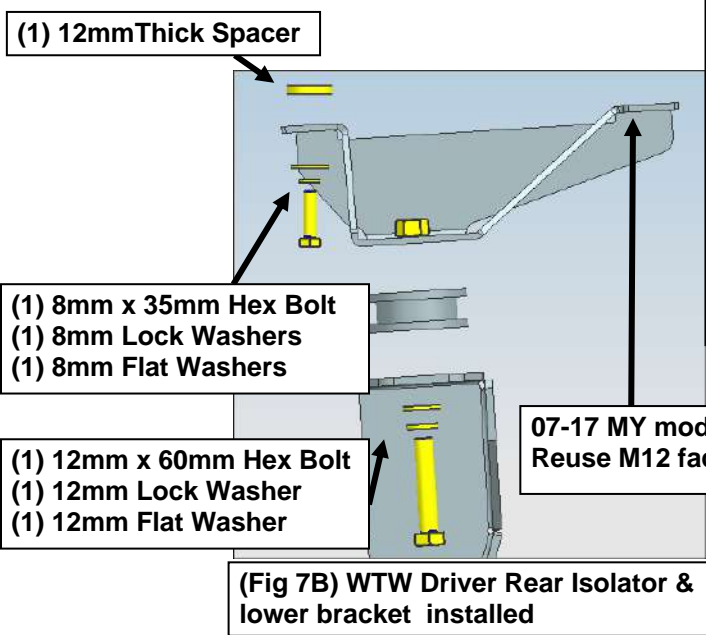

(1) 12mm Thick Spacer

(1) 8mm x 35mm Hex Bolt
 (1) 8mm Lock Washers
 (1) 8mm Flat Washers

(1) 12mm x 60mm Hex Bolt
 (1) 12mm Lock Washer
 (1) 12mm Flat Washer

(Fig 7B) WTW Driver Rear Isolator & lower bracket installed

2018 MY models:
 Use provided hardware to attach the bracket:
 (1)12mm Bolt Plate
 (1)Plastic Retainer
 (1)12mm x 29mm x 2mm Flat Washer
 (1)12mm x 24mm x 2.5mm Flat Washer
 (1)12mm Lock Washer
 (1)12mm Hex Nut

07-17 MY models:
 Reuse M12 factory bolts

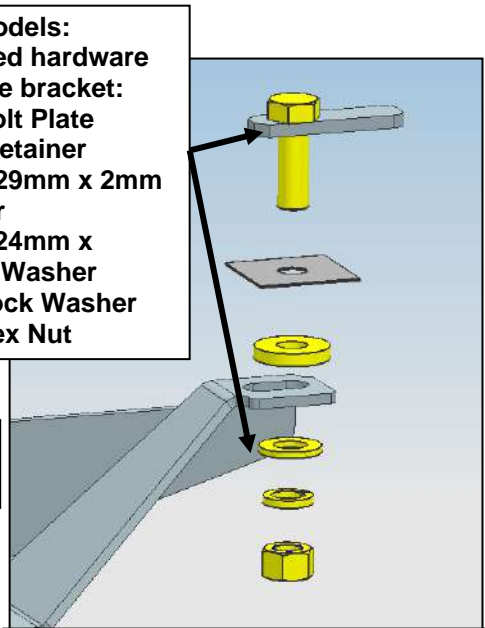

(Fig 7C) WTW Driver Rear Isolator & lower bracket installed

For 2007-2018 Chevy/GMC Silverado/Sierra 1500 Crew Cab/ Extended Cab/Double Cab / 6.5ft Bed/
2007-2019 Chevy/GMC Silverado/Sierra 2500/3500 Crew Cab/ Extended Cab/Double Cab / 6.5ft Bed/
(Incl. Diesel Models With DEF Tanks)(Excludes 07 Classic Models)(Incl. 2019 Silverado 1500 LD)

Rev:20190201

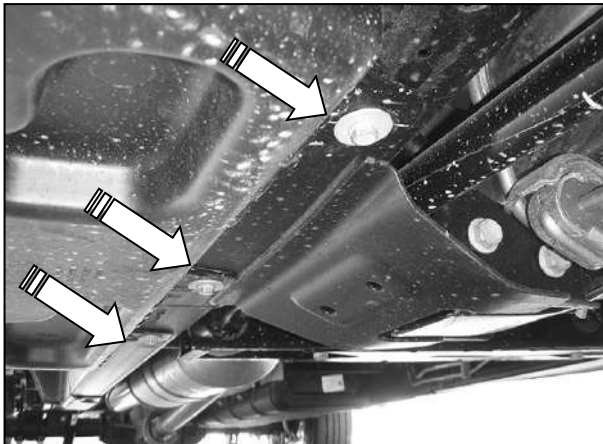

(Fig 8) 07-16 Passenger side front pictured with DEF tank cover. Remove (3) hex bolts to remove cover

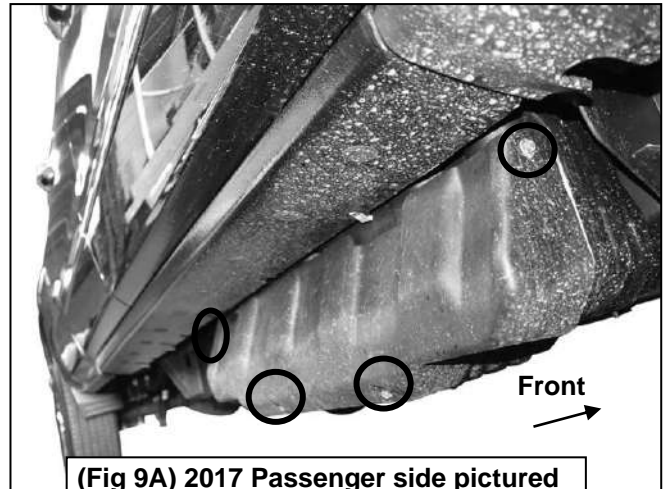

(Fig 9A) 2017 Passenger side pictured with DEF plastic tank cover. Remove (4) hex bolts to remove plastic cover

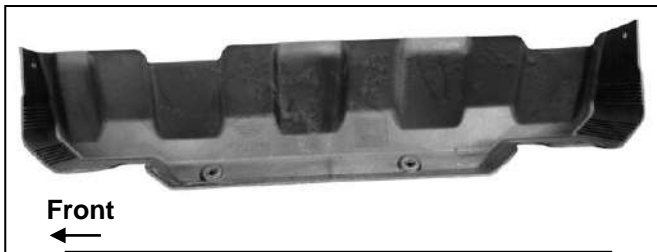

(Fig 9B) 2017 Passenger side DEF cover

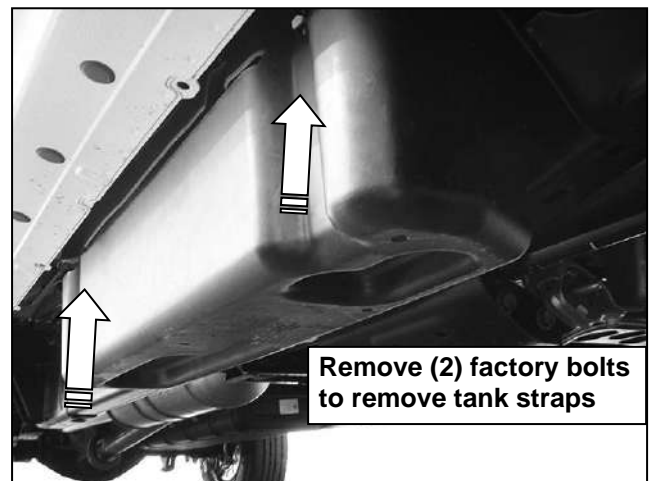

Remove (2) factory bolts to remove tank straps

(Fig 10) 07-16 Passenger side DEF tank and cover

Models with 8mm threaded insert in body panel:
8mm x 25mm Hex Bolt
8mm Lock Washer
8mm Flat Washer

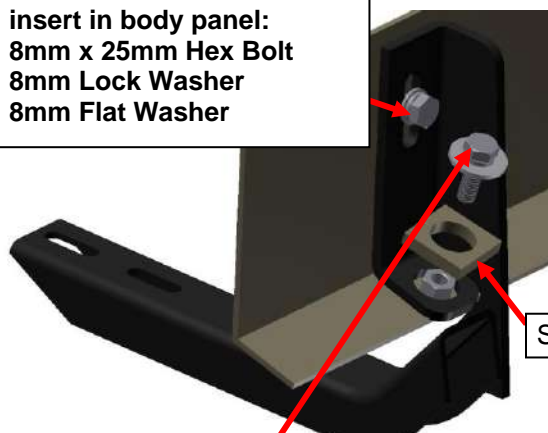

SQ Spacer

Models with weld nut on Pitch Weld:
8mm x 25mm Hex Bolt
8mm Lock Washer
8mm Flat Washer
to attach Bracket to weld nut

(Fig 11) Passenger Front Bracket over weld nut if equipped-also see Figure 2

Models with hole on Rocker Panel:
8mm Clip-Nut
8mm Flat Washer
8mm Lock Washer
8mmX25mm Hex Bolt

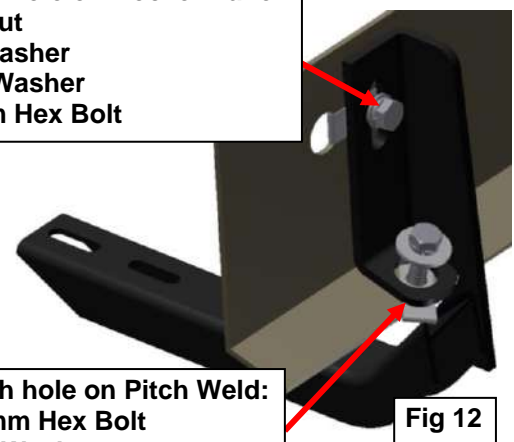
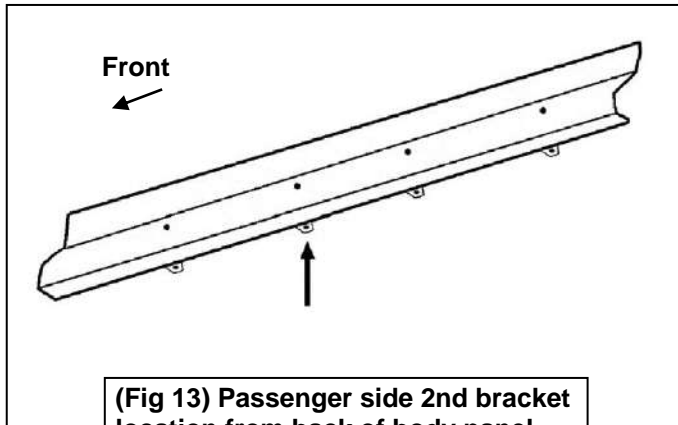

Fig 12

Models with hole on Pitch Weld:
8mm x 25mm Hex Bolt
8mm Lock Washer
8mm Large Flat Washer

For 2007-2018 Chevy/GMC Silverado/Sierra 1500 Crew Cab/ Extended Cab/Double Cab / 6.5ft Bed/
2007-2019 Chevy/GMC Silverado/Sierra 2500/3500 Crew Cab/ Extended Cab/Double Cab / 6.5ft Bed/
(Incl. Diesel Models With DEF Tanks)(Excludes 07 Classic Models)(Incl. 2019 Silverado 1500 LD)
Rev:20190201



(Fig 13) Passenger side 2nd bracket location from back of body panel

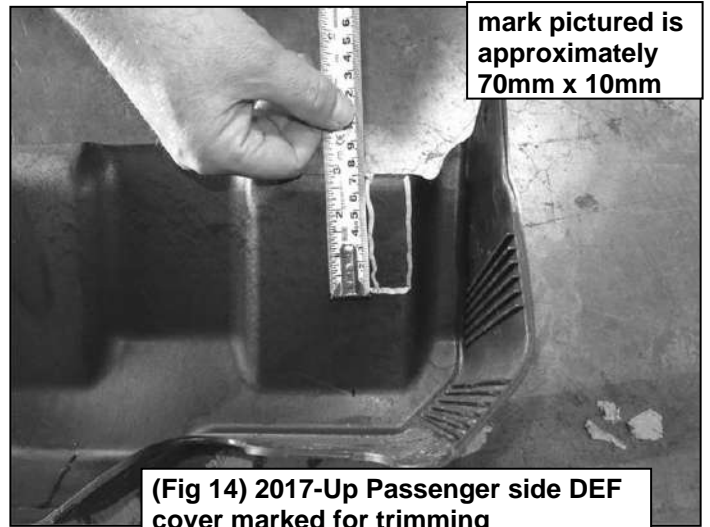

(Fig 14) 2017-Up Passenger side DEF cover marked for trimming

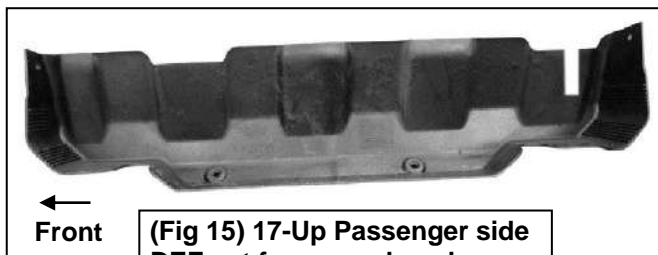

(Fig 15) 17-Up Passenger side DEF cut for example only



(Fig 16) Slip 6mm T-bolts into the bottom channel

- (2)M6 T-bolts
- (2)M6 Flat Washers
- (2)M6 Nylon Lock nuts

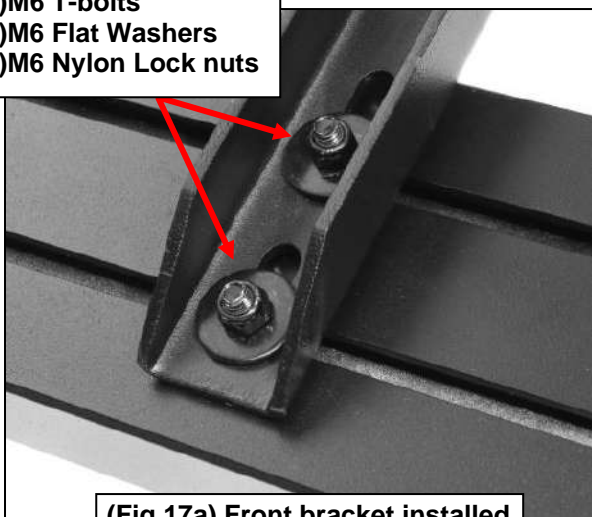

(Fig 17a) Front bracket installed

- (4)M6 T-bolts
- (4)M6 Flat Washers
- (4)M6 Nylon Lock nuts

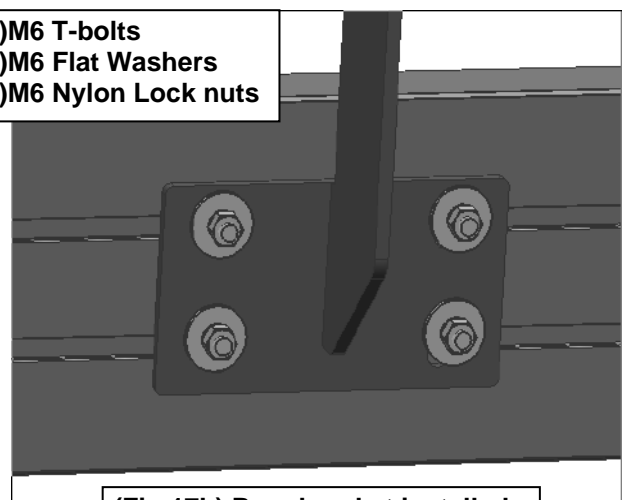

(Fig 17b) Rear bracket installed