

iBoard®



Scan for
Installation Video

iBoard® by APS

PART#: IB-R159/R258

READ INSTRUCTIONS CAREFULLY BEFORE STARTING INSTALLATION. REMOVE CONTENTS FROM BOX AND VERIFY ALL PARTS ARE PRESENT. ASSISTANCE IS RECOMMENDED.

*ROCKER PANEL MOUNT
*NO DRILLING REQUIRED

Fastener Size	Tightening Torque (ft-lbs)	Required
6mm	6-7	√
8mm	16-18	√
10mm	31-32	X
12mm	56-58	X
14mm	92-94	X

Driver

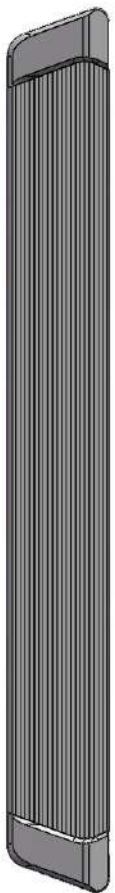

Front



Passenger

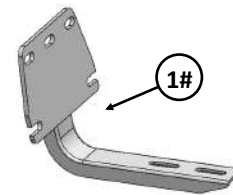
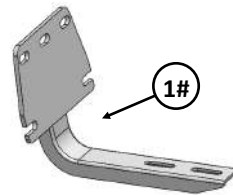
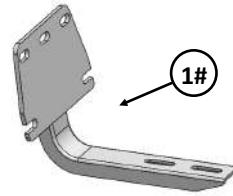
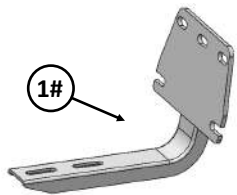
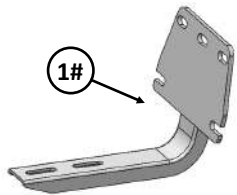
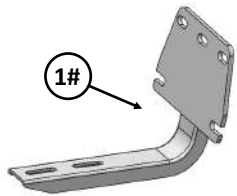
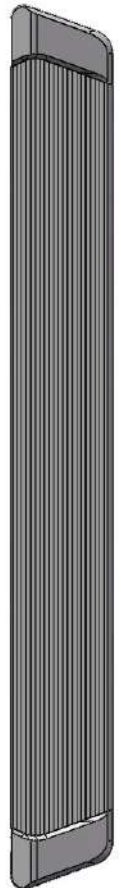

NOTE: All Mounting Brackets are universal.



Scan for
Installation Video

Hardware Package A (For Bracket Installation)

Item	QTY	Description	Item	QTY	Description
1#	6	Mounting Brackets	3#	18	M8X1.25 Nylon Lock Nuts
2#	18	M8 Large Flat Washers			



2 #



3 #

Hardware Package B (For Step Bar Installation)

Item	QTY	Description	Item	QTY	Description
1#	12	M6X1-20mm Square Head Bolts	3#	12	M6 Nylon Lock Nuts
2#	12	M6 Large Flat Washers			



1#



2#



3#



STEP 1

Start the installation under the driver side of the vehicle. Locate the front (3) factory studs along the inner side of the body panel, (Fig 1).

NOTE: Use a wire brush to remove paint on the threaded studs if equipped.

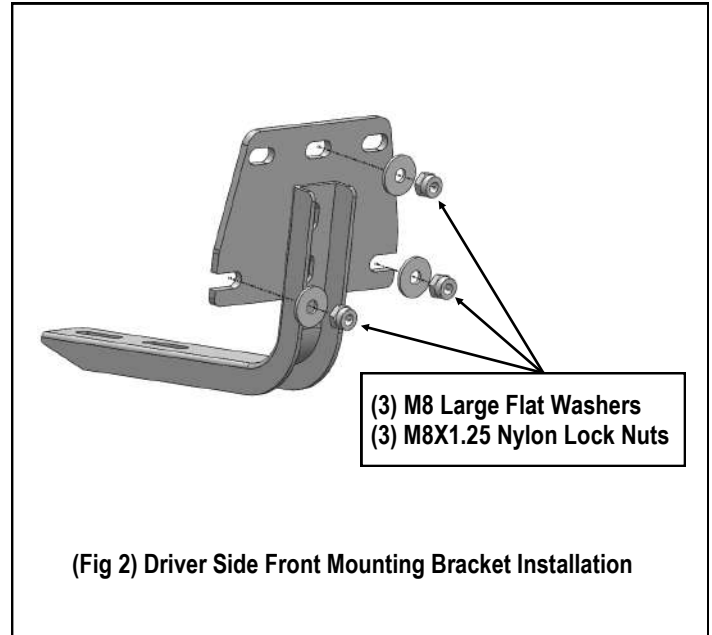
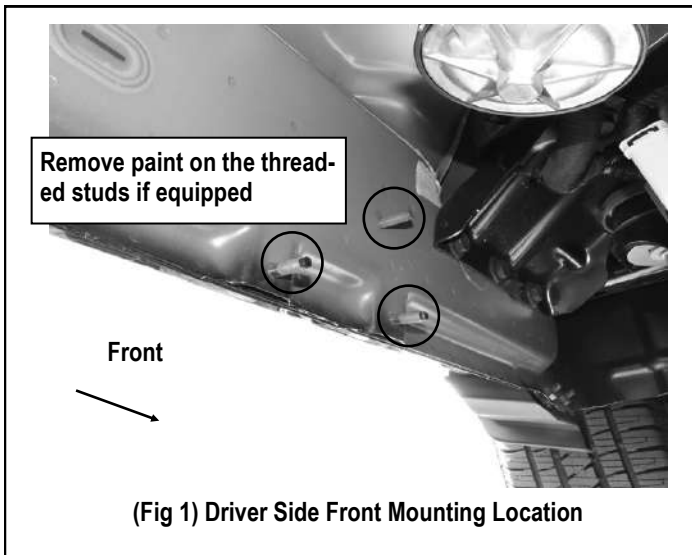

STEP 3

Move to Driver side Center and Rear mounting locations, (Figs 3-4). Repeat **Steps 1-2** to install Driver Center Mounting bracket and Driver Rear Mounting bracket. Do not fully tighten hardware at this time.

STEP 2

Select (1) Mounting Bracket. Attach the Mounting Bracket to the (3) factory studs on the Driver Side Front Mounting Bracket Location with (3) M8 Large Flat Washers and (3) M8X1.25 Nylon Lock Nuts, (Fig 2). Do not fully tighten the hardware at this time.

NOTE: All (6) Mounting Brackets are universal .

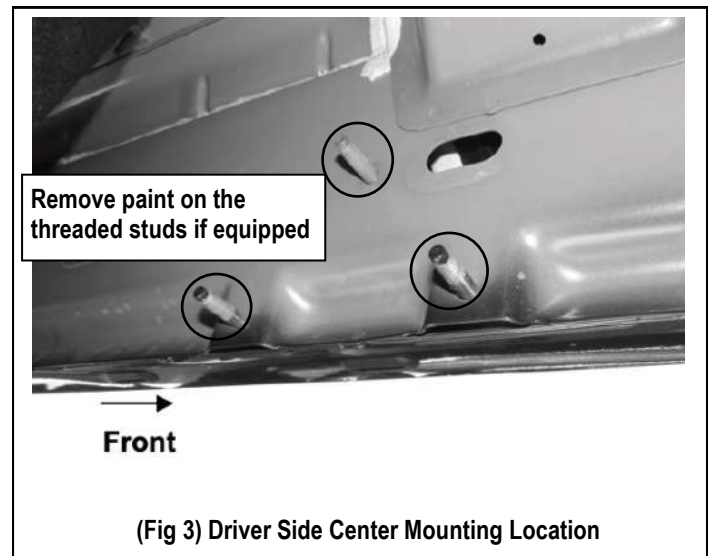

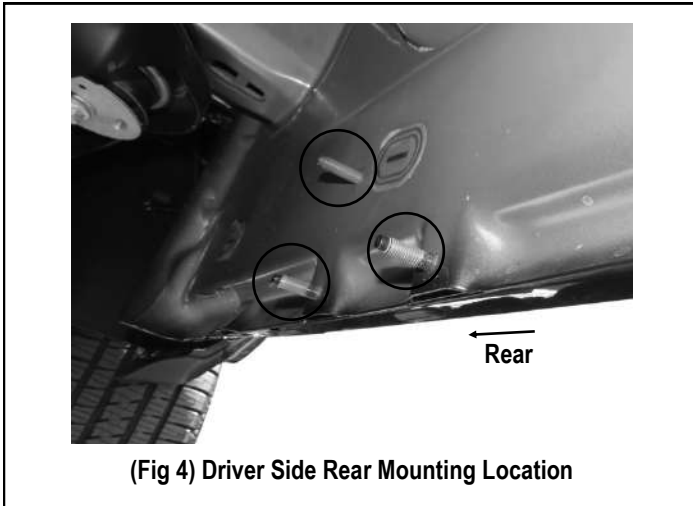

(Fig 4) Driver Side Rear Mounting Location

STEP 4

Once all (3) Mounting Brackets have been installed, select a Running Board. Slip (3) M6X1-20mm Square Head Bolts into each bottom channel (Fig 5). Carefully position the Running Board onto the (3) Mounting Brackets. Attach the Running Board to each Mounting Brackets with (2) M6X1-20mm Square Head Bolts, (2) M6 Large Flat Washers and (2) M6 X1 Nylon Lock Nuts (Fig 6). Do not fully tighten at this time.

IMPORTANT: Do not slide the Running Board on the Brackets or the bottom surface of the board will be damaged.

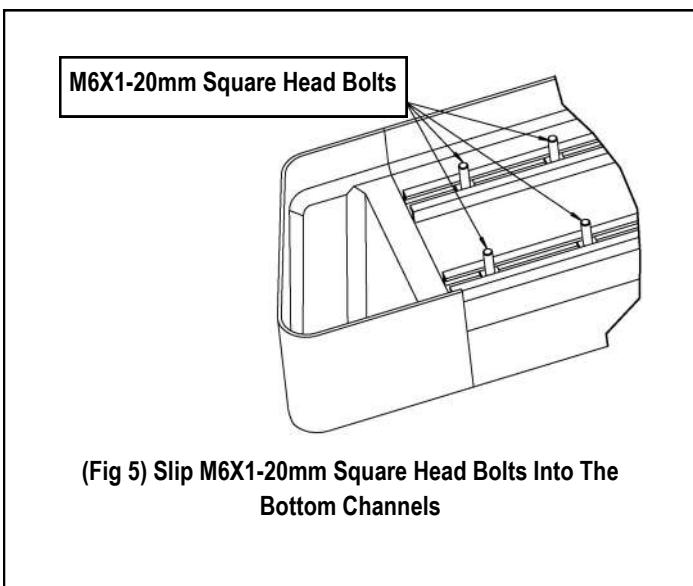

(Fig 5) Slip M6X1-20mm Square Head Bolts Into The Bottom Channels

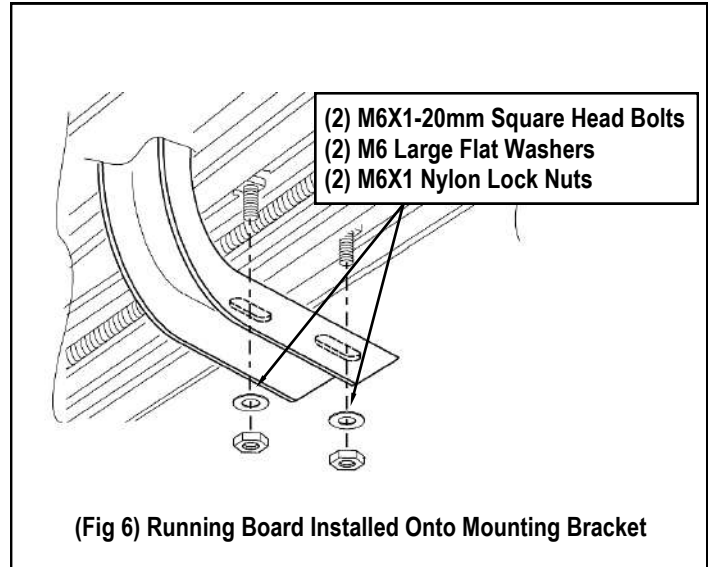

(Fig 6) Running Board Installed Onto Mounting Bracket

STEP 5

Level and adjust the Running Board and fully tighten all hardware.

Important: Please follow the recommended Tightening Torques shown in the table on page 1. Don't over tighten, or the nuts/bolts will be damaged.

STEP 6

Repeat **Steps 1-5** for the other side Running Board installation. The installation is completed .

Attention

Do periodic inspections to the installation to make sure that all hardware is secure and tight.

In order to protect your bars/boards, please use mild soap/non-abrasive products for cleaning only.