

iBoard®



Scan for
Installation Video

iBoard® by APS

PART#: IB-R179/R208/R209

READ INSTRUCTIONS CAREFULLY BEFORE STARTING INSTALLATION. REMOVE CONTENTS FROM BOX AND VERIFY ALL PARTS ARE PRESENT. ASSISTANCE IS RECOMMENDED.

*ROCKER PANEL MOUNT
*DRILLING MAY BE REQUIRED

Fastener Size	Tightening Torque (ft-lbs)	Required
6mm	6-7	√
8mm	16-18	√
10mm	31-32	√
12mm	56-58	X
14mm	92-94	X

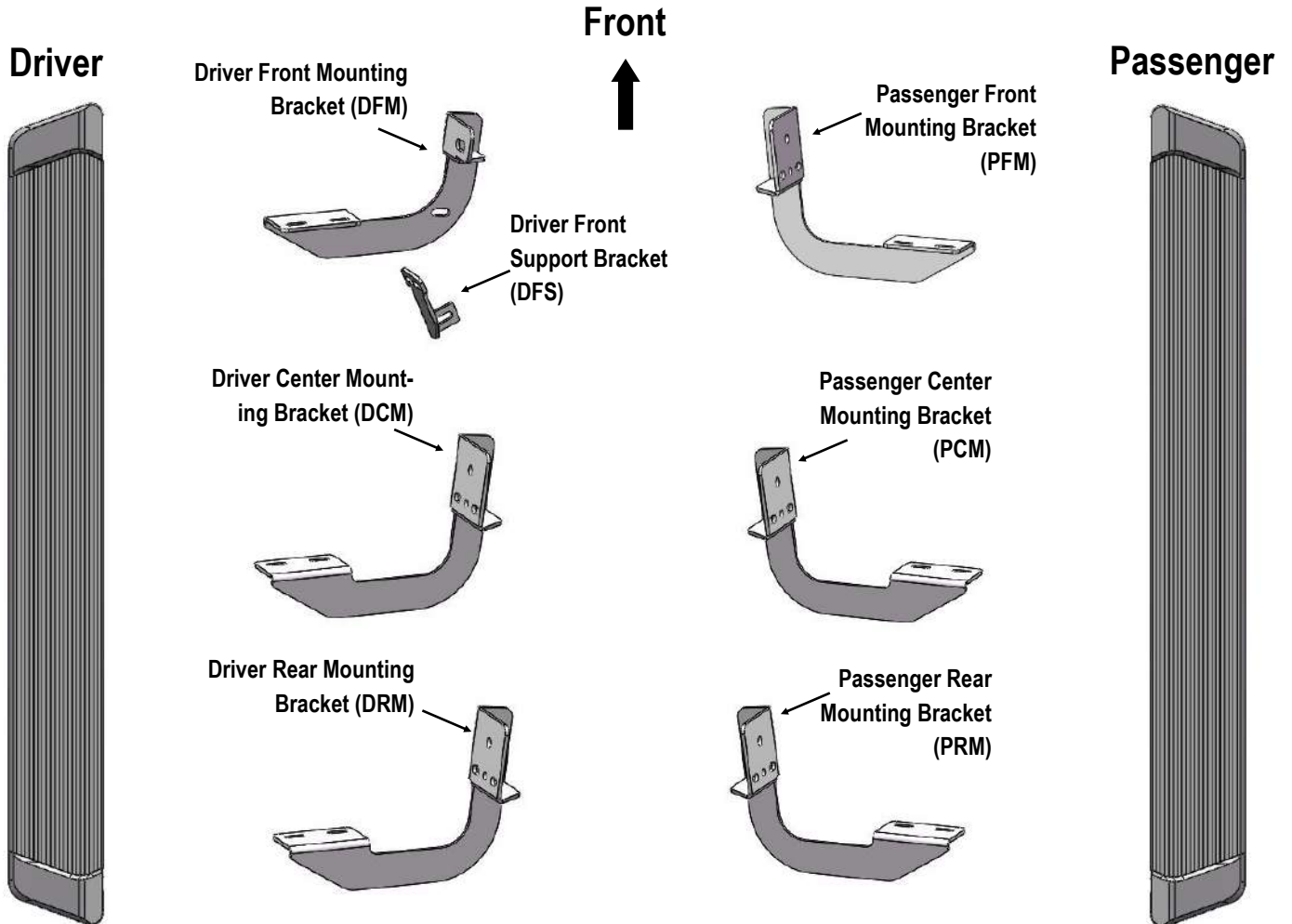

Customer Support: info@iboardauto.com



Hardware Package A (For Bracket Installation)					
Item	QTY	Description	Item	QTY	Description
1#	6	M10 Bolt/Nut Plates	9#	5	M10 Rivet Nuts
2#	6	M10 Plastic Washers	10#	12	M8X1.25-30mm Hex Bolts
3#	6	M10X1.5-40mm Hex Bolts	11#	13	M8 Large Flat Washers
4#	5	M10X1.5-30mm Hex Bolts	12#	11	M8 Lock Washers
5#	5	M10 Large Flat Washers	13#	1	M8 Nylon Lock Nut
6#	11	M10 Flat Washers	14#	2	M6X1-25mm Hex Bolts
7#	16	M10 Lock Washers	15#	4	M6 Large Flat Washers
8#	5	M10 Hex Nuts	16#	2	M6 Nylon Lock Nuts

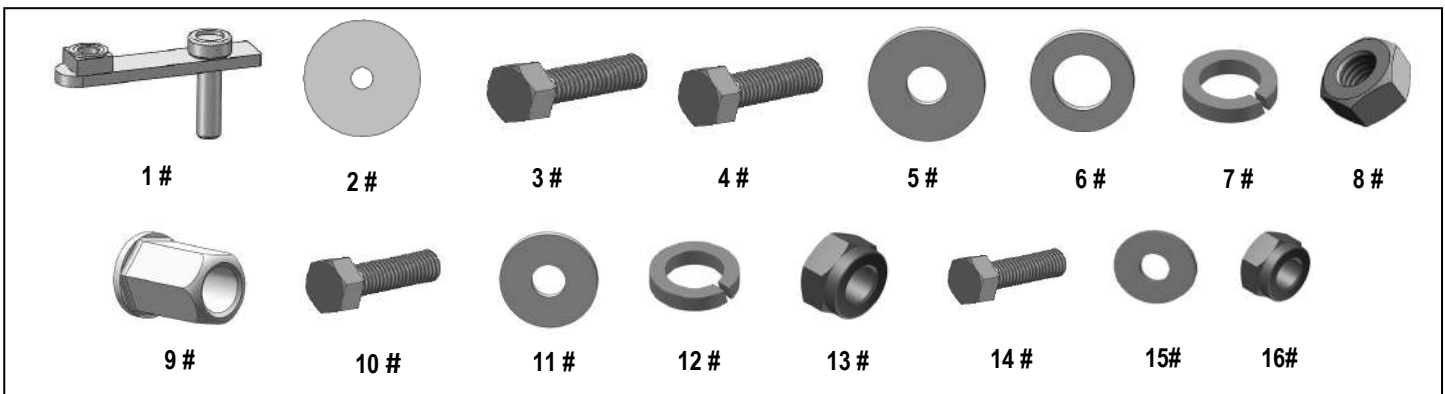

Hardware Package B (For Step Bar Installation)					
Item	QTY	Description	Item	QTY	Description
1#	12	M6X1-20mm Square Head Bolts	3#	12	M6 Nylon Lock Nuts
2#	12	M6 Large Flat Washers			

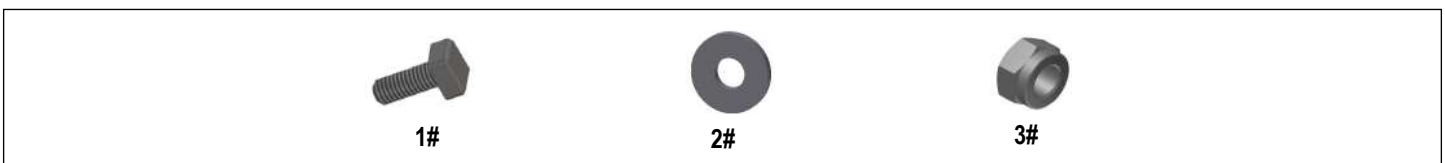



STEP 1

Start installation on the driver side of the vehicle. If equipped, remove the sealing tapes covering the factory oval holes on the inner side of the body panel, (Fig 1A & 1B & 1C).

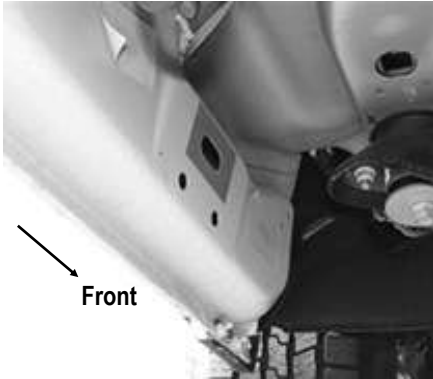

(Fig 1) Driver Side Front Mounting Location

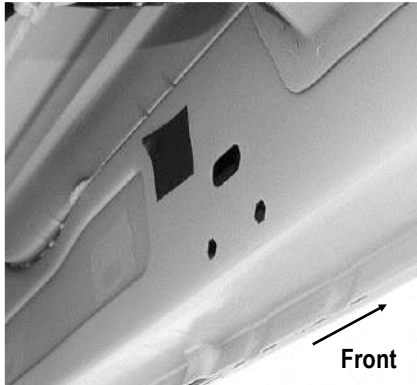

(Fig 1B) Driver Side Center Mounting Location

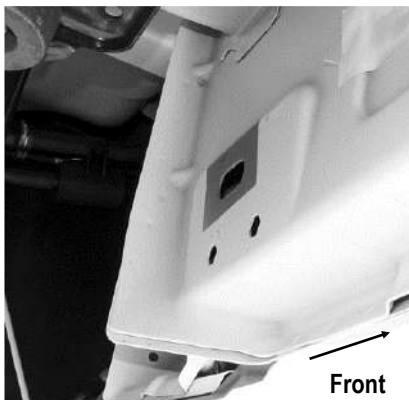

(Fig 1C) Driver Side Rear Mounting Location

STEP 2

Determine the correct procedure to install (1) Driver Front Mounting Bracket for your model/year:

Models without factory threaded inserts in body panel:

- Insert the M10 Bolt/Nut Plate into the factory oval hole. And then Thread down the M10 Plastic Washer onto the M10 bolt until it is flush against the sheet metal to prevent the M10 Bolt/Nut Plate from falling down into the oval hole, (Fig 2).
- Attach the Driver Front Mounting Bracket to the inner panel and rotate the M10 Bolt/Nut Plate until the welded nut end lines up with the hole on the Mounting Bracket. Secure with (1) M10x1.5-40mm Hex Bolt, (1) M10 Lock Washer and (1) M10 Flat Washer, (Fig 6). Keep them snug but do not tighten hardware at this time.

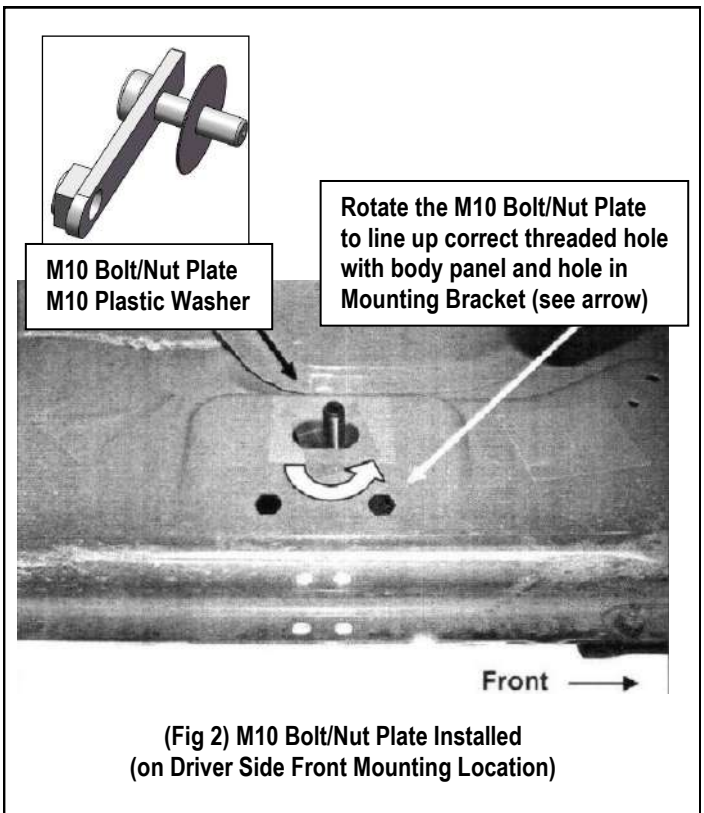

(Fig 2) M10 Bolt/Nut Plate Installed
(on Driver Side Front Mounting Location)



STEP 3

Models with factory threaded inserts, (Fig 3):

Attach the Driver Front Mounting Bracket onto the threaded insert with (1) M8X1.25-30mm Hex Bolt, (1) M8 Lock Washer, (1) M8 Large Flat Washer, (Fig 6). Do not fully tighten at this time.

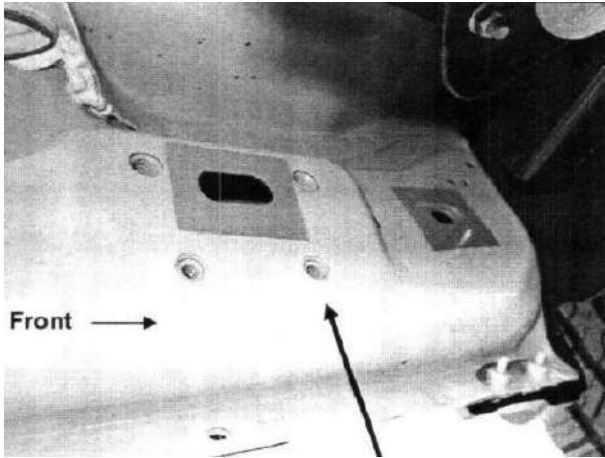

(Fig 3) Driver Side Front Mounting Location
(Example of models with factory installed threaded inserts)

STEP 4

Attach the Driver Front Support Bracket to the Driver Front Mounting Bracket with (1) M8X1.25-30mm Hex Bolt, (2) M8 Large Flat Washers and (1) M8 Nylon Lock Nut, (Fig 4).

Rotate the Support Bracket to attach the back of the pinch weld with (2) M6X1-25mm Hex Bolts, (4) M6 Large Flat Washers, (2) M6 Nylon Lock Nuts. (Figs 5 & 6). Do not Fully tighten at this time.

Important: To attach the Support Bracket, drilling may be required for some models w/o factory holes on the pinch weld. Do not drill through pinch weld at this time. (Refer to Step 9)

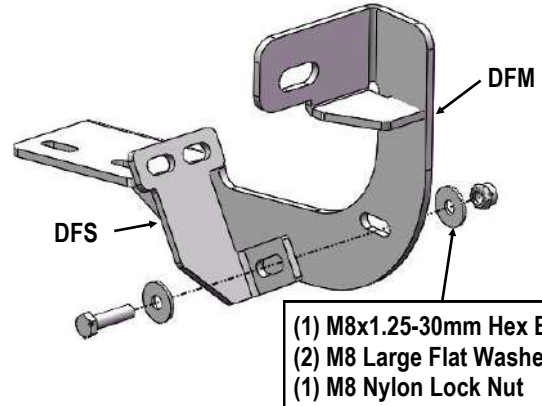

(Fig 4) Driver Side Front Mounting Brackets Assembly

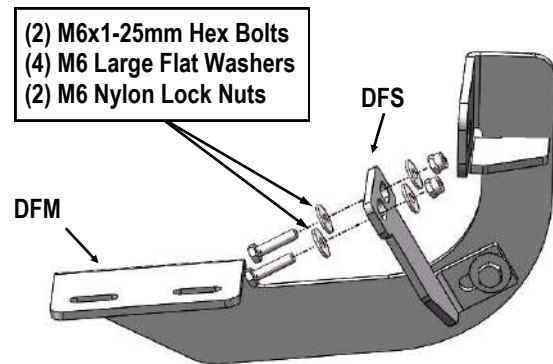

(Fig 5) Driver Front Support Bracket Installed

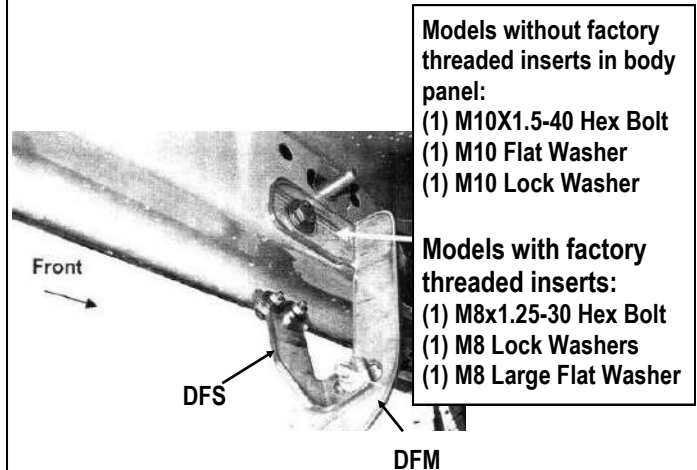

(Fig 6) Driver Side Front Brackets Installed



STEP 5

Move to the driver side Center Mounting Location:

Models w/o factory threaded inserts on body panel:

Select (1) M10 Bolt/Nut Plate, repeat **Step 2** to install the M10 Bolt/Nut Plate into the oval hole (**Fig 7**).

Insert (1) M10 Rivet Nut into the hole on rocker panel, and attach the Center Bracket onto the installed M10 Bolt/Nut Plate temporarily with (1) M10X1.5 Hex Nut, (1) M10 Large Flat Washer, (1) M10 Lock Washer. And use the mounting bracket as a tool to secure the M10 Rivet Nut onto the rocker panel with (1) M10X1.5-30mm Hex Bolt, (1) M10 Large Flat Washer and (1) M10 Lock Washer, (**Fig 8**). After the M10 rivet nut installed, remove the M10 hardware from the center hole of the mounting bracket, (**Fig 8**).

And then Attach the Driver Center Mounting Bracket on the installed M10 Rivet Nut and M10 Bolt Nut/Plate, (**Fig 9**).

Models with factory threaded inserts. (Fig 3):

Attach the Driver Centre Mounting Bracket onto the factory threaded insert with (2) M8X1.25-30mm Hex Bolt, (2) M8 Lock Washer, (2) M8 Large Flat Washer (**Fig 9**). Do not fully tighten hardware at this time.

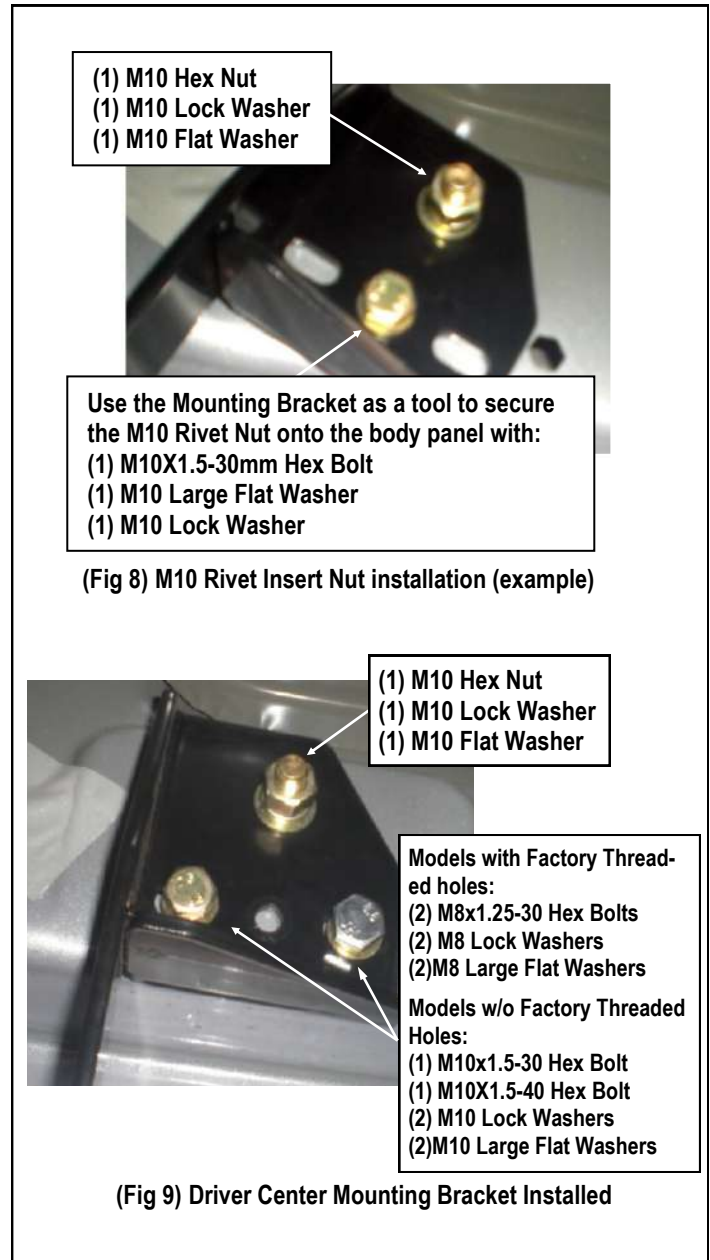
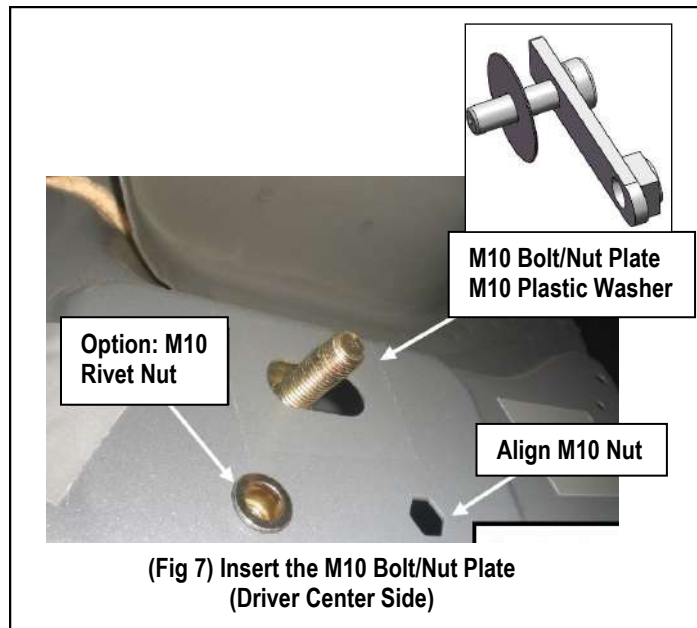

STEP 6

Move to the driver side rear of the vehicle, repeat **Step 5** for Driver Rear Mounting Bracket installation.

Note: Driver Center & Rear Mounting Bracket are universal.



STEP 7

Once all (3) mounting brackets are installed. Select a Running Board. Slip (3) M6X1-20mm Square Head Bolts into each bottom channel (**Fig 10**). Carefully position the Running Board onto the (3) Mounting Brackets. Attach the Running Board to each Mounting Bracket with (2) M6X1-20mm Square Head Bolts, (2) M6 Large Flat Washers and (2) M6 X1 Nylon Lock Nuts (**Fig 11**). Do not fully tighten at this time.

IMPORTANT: Do not slide the Running Board on the Brackets or the bottom surface of the board will be damaged.

M6X1-20mm Square Head Bolts

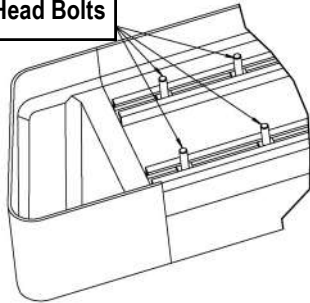

(Fig 10) Slip M6X1-20mm Square Head Bolts Into The Bottom Channels

(2) M6X1-20mm Square Head Bolts
(2) M6 Large Flat Washers
(2) M6X1 Nylon Lock Nuts

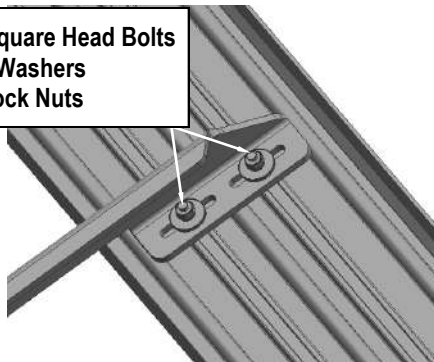

(Fig 11) Running Board Installed Onto Mounting Bracket

STEP 8

Level and adjust the Running Board and fully tighten all hardware.

Important: Please follow the recommended Tightening Torques shown in the table on page 1. Don't over tighten, or the nuts/bolts will be damaged.

STEP 9

Some Models requiring **drilling** for Driver Front Support Bracket:

- Make sure the sidebar is level to the vehicle. Line up the slot on the Support Bracket with the back of the pinch weld. Mark the location of the slot onto the pinch weld.
- Drill (2) ¼" holes through the pinch weld. **Important:** Do not drill too close to the bottom edge of the pinch weld. Drill the holes toward the outside of the marked slot.
- Attach the Support Bracket to the pinch weld with (2) M6 X1-25mm Hex Bolts, (4) M6 Large Flat Washers, (2) M6 nylon Lock Nuts. (**Fig 6**).
- Check for level then fully tighten all hardware.

STEP 10

Repeat **Steps 1-8** for the other side Running Board installation. The installation is completed .

Attention

Do periodic inspections to the installation to make sure that all hardware is secure and tight.

In order to protect your bars/boards, please use mild soap/non-abrasive products for cleaning only.