

iBoard®

iBoard® by APS

PART#: IB-310

READ INSTRUCTIONS CAREFULLY BEFORE STARTING INSTALLATION. REMOVE CONTENTS FROM BOX AND VERIFY ALL PARTS ARE PRESENT. ASSISTANCE IS RECOMMENDED.

*ROCKER PANEL MOUNT
*NO DRILLING REQUIRED

| Fastener Size | Tightening Torque (ft-lbs) | Required |
|---------------|----------------------------|----------|
| 6mm | 6-7 | √ |
| 8mm | 16-18 | √ |
| 10mm | 31-32 | √ |
| 12mm | 56-58 | X |
| 14mm | 92-94 | X |

PART LIST

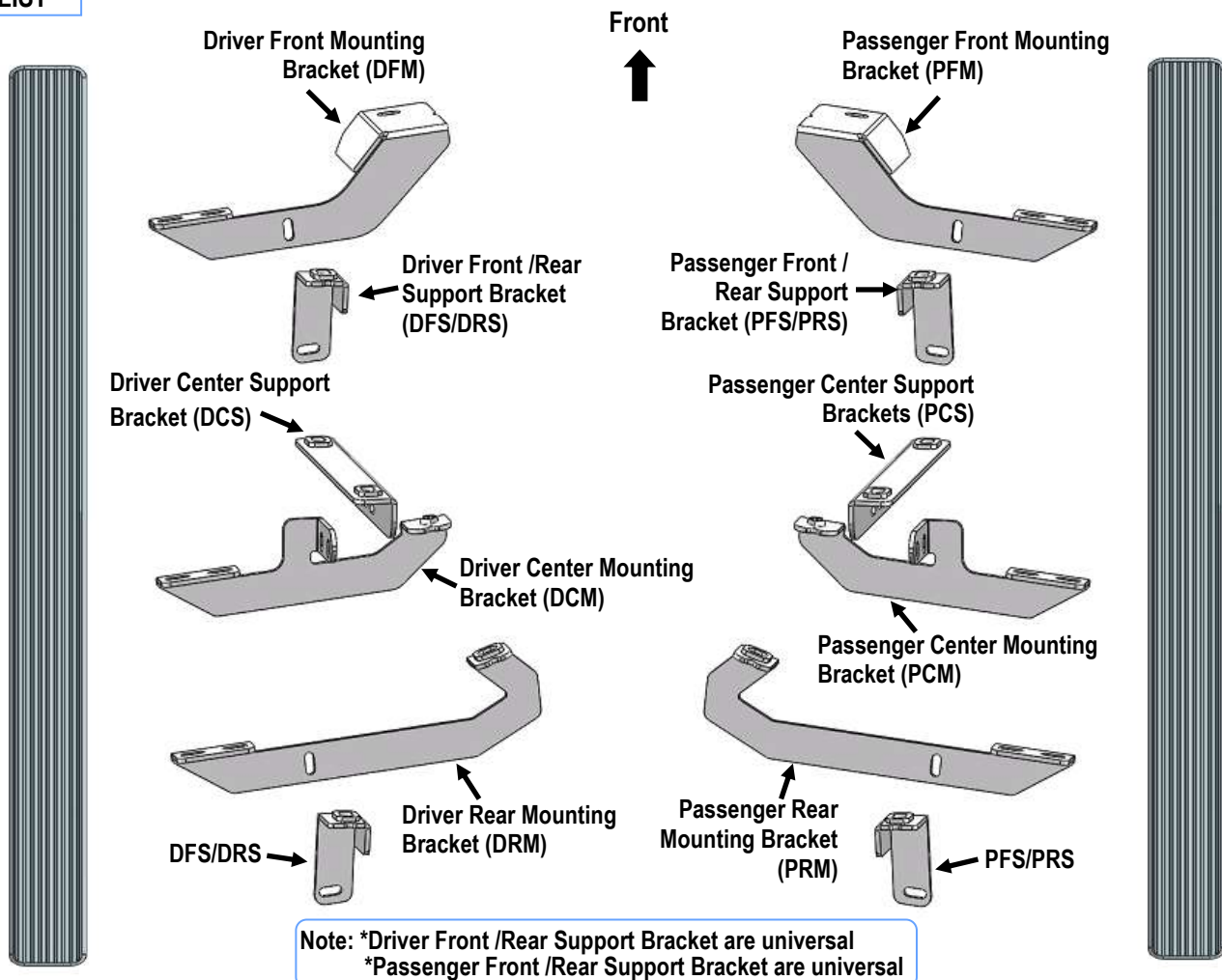

Customer Support: info@iboardauto.com

iBoard®

Hardware Package A (For Bracket Installation)

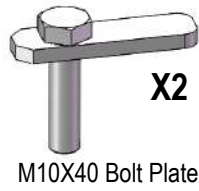
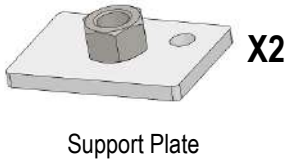

Hardware Package B (For Aluminum Step Bar Installation Only, Not Supply to Stainless Steel Step Bar)



Hardware Package C (For Stainless Steel Step Bar Installation Only, Not Supply to Aluminum Step Bar)



iBoard®

STEP 1

Start the installation from Driver Side Mounting Locations of the vehicle, remove the large plastic cover on the bottom of the floor panel, (**Fig 1**). Determine which plastic clips need to be removed. Carefully remove only the plastic clips for installation.

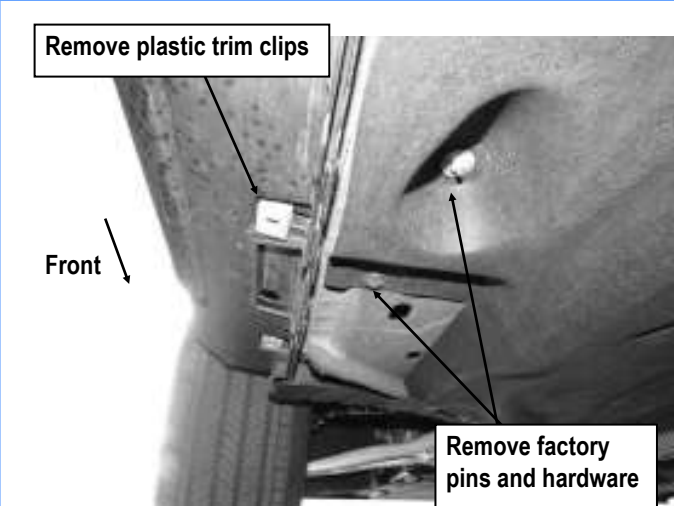

(Fig 1) Driver Side Front Mounting Location

STEP 2

Locate the Driver Side Front Mounting Location, (**Fig 2**). Select (1) M10 J-Bolt, insert the M10 J-Bolt into the side panel, (**Fig 5**).

- With the M10 J-Bolt threads pointing away from the vehicle, insert the tail all the way up into the slot. Keep threads pointed outwards, (**Fig 3a**).
- Slide in the bend in the tail up into the slot, keeping the threads pointed outwards, (**Fig 3b**).
- Rotate M10 J-Bolt downwards so that the threads are pointed towards the ground, (**Fig 3c**).

Select (1) M10X35 Bolt Plate, insert the Bolt Plate into the floor panel, (**Fig 2**). Thread (1) M10 Plastic Washer onto the Bolt Plate to hold it in place

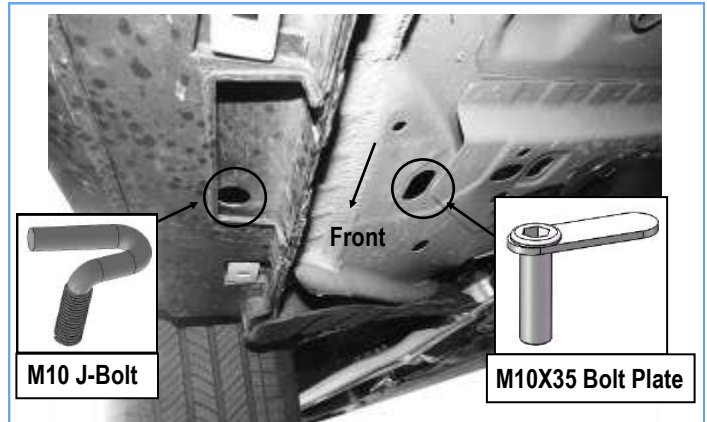

(Fig 2) Driver Side Front Mounting Location



(Fig 3a) Insert (1) M10 J-Bolt



(Fig 3b) Insert (1) M10 J-Bolt



(Fig 3c) Insert (1) M10 J-Bolt

iBoard®

STEP 3

Select the Driver Front Mounting Bracket (**DFM**) and the Driver Front Support Bracket (**DFS/DRS**), assembly with (1) M8X1.25-25mm Hex Bolt, (2) M8 Flat Washers, (1) M8 Lock Washer and (1) M8X1.25 Hex Nut, (**Fig 4**). Do not fully tighten at this time.

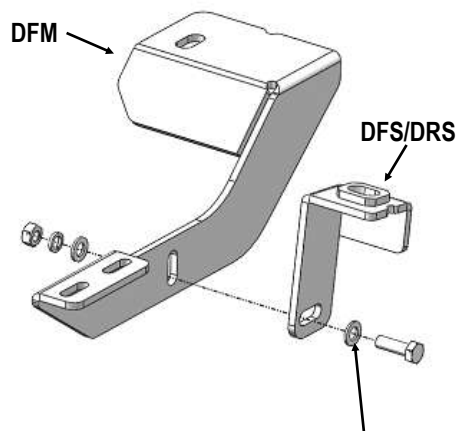

- (1) M8X1.25-25mm Hex Bolt
- (1) M8 Lock Washer
- (2) M8 Flat Washers
- (1) M8X1.25 Hex Nut

(Fig 4) Driver Side Front Brackets Assembly

STEP 4

Attach the assembled Mounting Bracket to the M10X35 Bolt Plate with (1) M10 Large Flat Washer, (1) M10 Lock Washer and (1) M10X1.5 Hex Nut; attach to the M10 J-Bolt with (1) M10 Large Flat Washer, (1) M10 Lock Washer and (1) M10X1.5 Hex Nut, (**Fig 5**). Do not fully tighten at this time.

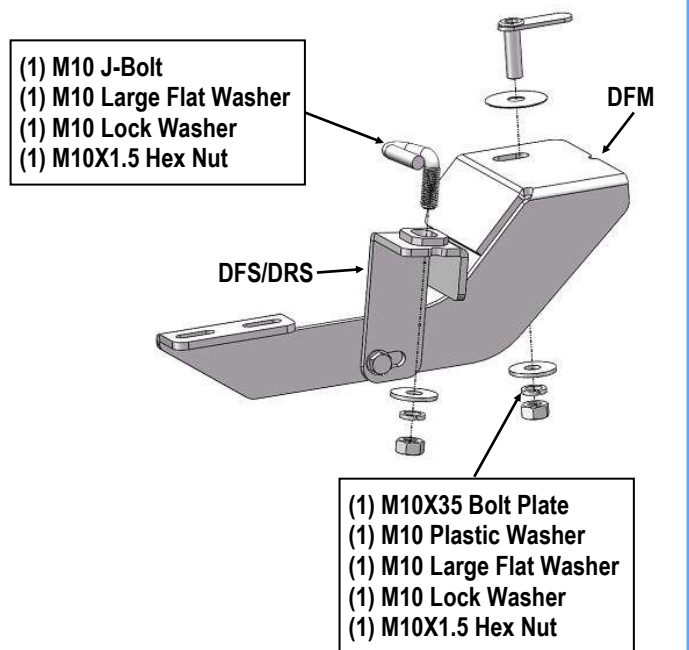

- (1) M10 J-Bolt
- (1) M10 Large Flat Washer
- (1) M10 Lock Washer
- (1) M10X1.5 Hex Nut

- (1) M10X35 Bolt Plate
- (1) M10 Plastic Washer
- (1) M10 Large Flat Washer
- (1) M10 Lock Washer
- (1) M10X1.5 Hex Nut

(Fig 5) Driver Side Front Mounting Bracket Installation

STEP 5

Select the Driver Center Mounting Bracket (**DCM**) and the Driver Center Support Bracket (**DCS**), assembly with (2) M8X1.25-25mm Hex Bolts, (4) M8 Flat Washers, (2) M8 Lock Washers and (2) M8X1.25 Hex Nuts, (**Fig 6**). Do not fully tighten at this time.

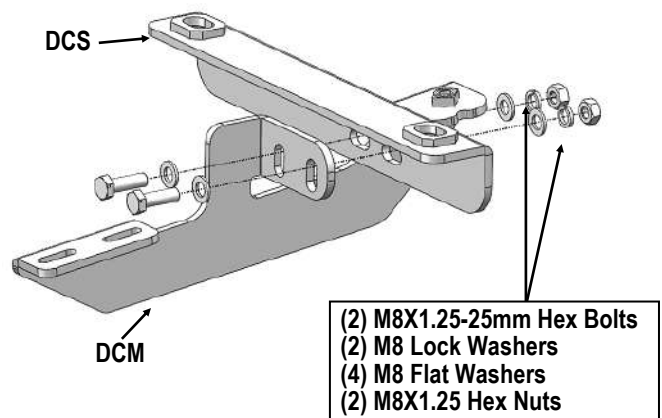

- (2) M8X1.25-25mm Hex Bolts
- (2) M8 Lock Washers
- (4) M8 Flat Washers
- (2) M8X1.25 Hex Nuts

(Fig 6) Driver Side Center Brackets Assembly

iBoard®

STEP 6

Move to the Driver Side Center Mounting Location, (**Fig 7**). Insert (2) M10 J-Bolts into the side panel, (**Fig 8**). Attach the Driver Center Support Bracket to the (2) M10 J-Bolts with (2) M10 Large Flat Washers, (2) M10 Lock Washers and (2) M10X1.5 Hex Nuts, (**Fig 9**). Do not fully tighten at this time.

Select (1) Support Plate.

- Thread (1) M10X1.5 Hex Nut to (1) M10X1.5-60mm Hex Bolt. Slide (1) M10 Lock Washer and (1) M10 Flat washer onto the M10X1.5-60mm Hex Bolt. (**NOTE:** Use the M10X1.5 Hex Nut to adjust the level of the Mounting Bracket.)
- Thread the M10 Hex Bolt assembly into the welded nut on the back of the Mounting Bracket. Place the Support Plate onto the end of the M10 Hex Bolt, (**Fig 9**).
- Tighten Hex Bolt to place the Support Plate onto the floor panel. Do not tighten Hex Bolt all the way.
- Follow link for Support Plate installation.

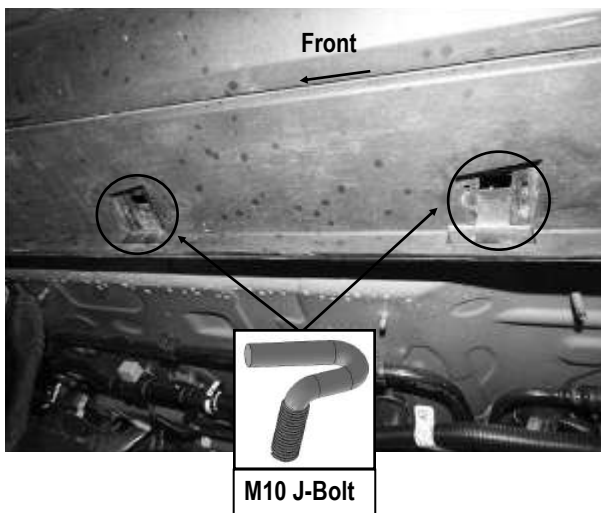

(Fig 7) Driver Side Front Mounting Location

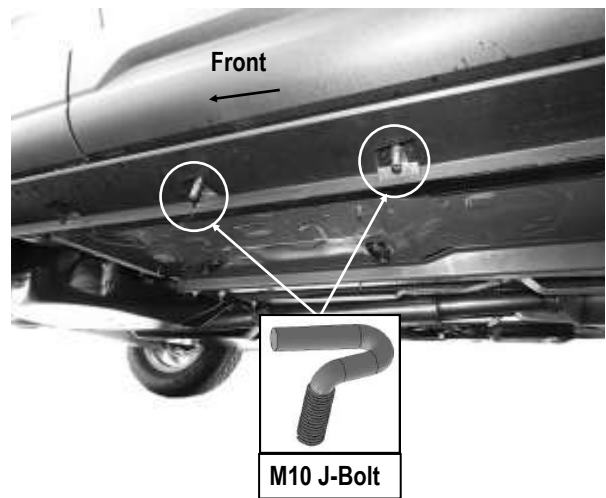

(Fig 8) Insert (2) M10 J-Bolts

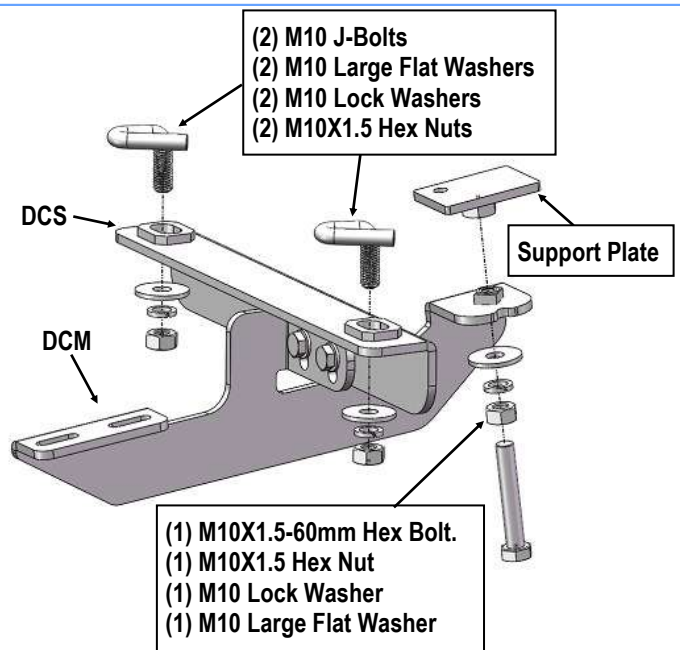

(Fig 9) Driver Side Center Brackets Installation

STEP 7

Move to the Driver Side Rear Mounting Location, (**Fig 10**). Repeat **Steps 2- 4** to attach the Driver Rear Mounting Brackets, (**Figs 10—13**). Do not fully tighten hardware.

iBoard®

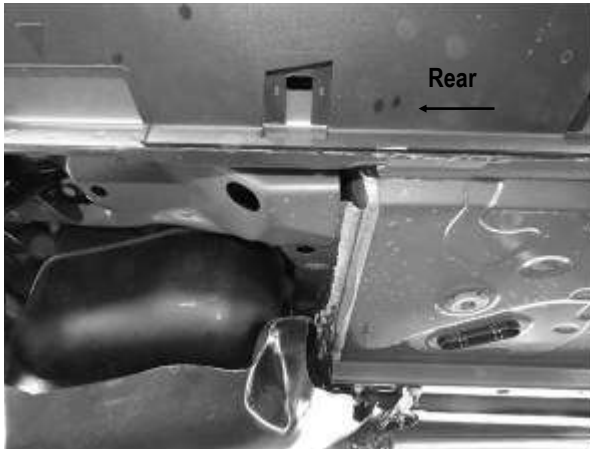

(Fig 10) Driver Side Rear Mounting Location

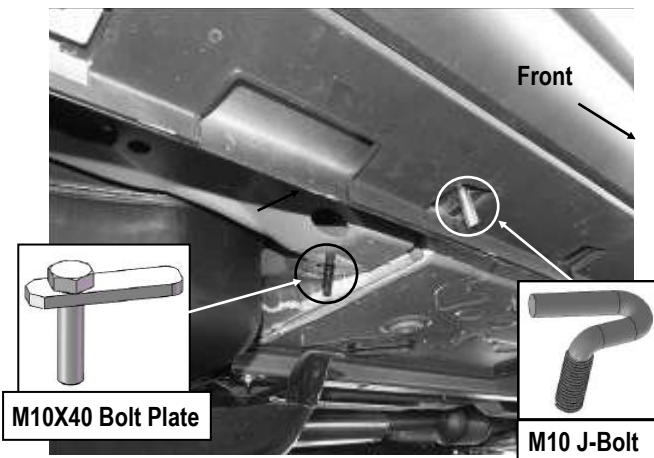

(Fig 11) Insert (1) M10 J-Bolt And (1) M10X40 Bolt Plate

- (1) M8X1.25-25mm Hex Bolt
- (1) M8 Lock Washer
- (2) M8 Flat Washers
- (1) M8X1.25 Hex Nut

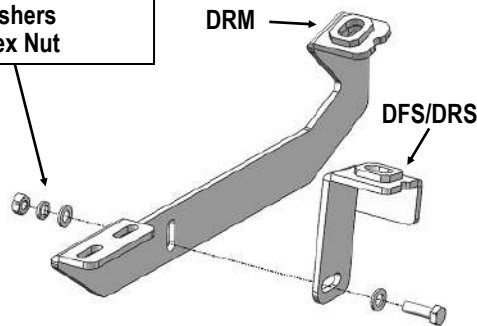

(Fig 12) Driver Side Center Brackets Assembly

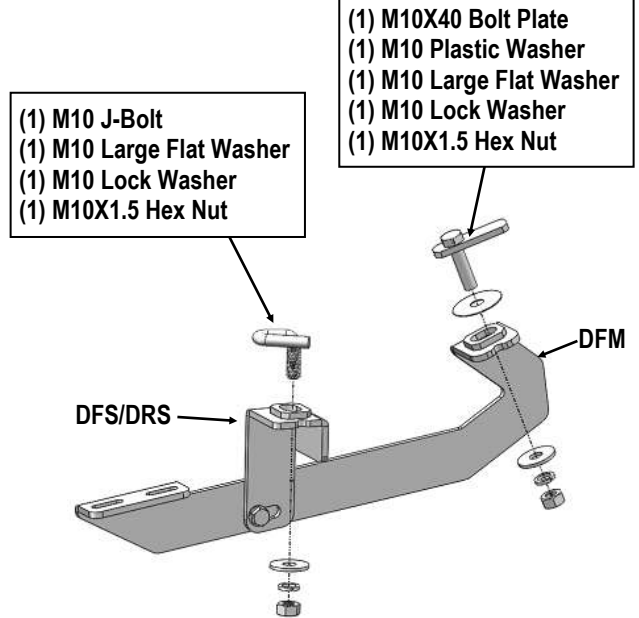

(Fig 13) Driver Side Rear Mounting Bracket Installation

STEP 8

Once all (3) mounting brackets are installed, then proceed to the Step Bar installation. According to the style of Step Bar proceed to the correct installation STEPS.

Note: Aluminum Step Bar refer to STEP 9; Stainless Steel Step Bar skip to STEP 10.

STEP 9

Aluminum Step Bar Installation:

Select a **Aluminum Step Bar**. Slip (3) M6x1-20mm Square Head Bolts into each bottom channel (Fig 14). Carefully position the Step Bar onto the (3) Mounting Brackets.

IMPORTANT: Do not slide the Step Bar on the Brackets or the bottom surface of the board will be damaged. Attach the Step Bar to each Mounting Brackets with (2) M6x1-20mm Square Head Bolts, (2) M6 Large Flat Washers and (2) M6X1 Nylon Lock Nuts, (Fig 15). Do not fully tighten at this time.

iBoard®

Level and adjust the Step Bar and fully tighten all hardware. Repeat **Steps 1-9** for the other side Step Bar installation. **The installation is completed!!!**



(Fig 14) Slip M6X1-20mm Square Head Bolts Into The Bottom Channels

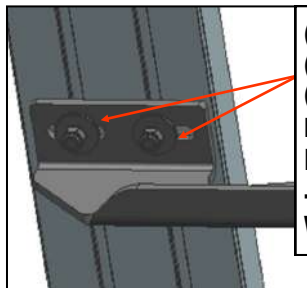

(2) M6X1-20mm Square Head Bolts
(2) M6 Large Flat Washers
(2) M6X1 Nylon Lock Nuts
IMPORTANT: TORQUE FOR 6MM FASTNERS MUST LESS THAN 6-7 FT-LBS OR THE FASTNERS WILL BE DAMAGED!

(Fig 15) Running Board Installed Onto Mounting Bracket

STEP 10

Stainless Steel Step Bar Installation:

Select a **Stainless Steel Step Bar** (with the U-Sliders installed on the Bar). Loose the U-Sliders, reposition the U-Sliders onto the board according to the (3) Installed Mounting Brackets location, (Fig 16). Re-secure the U-Sliders on the Step Bar. Attach the Step Bar to the installed Mounting Brackets with (6) M6X1-20mm Hex Bolts, (6) M6 Large Flat Washers & (6) M6 Lock Washers, (Fig 17). Do not fully tighten hardware at this time. Level and adjust the Step Bar and fully tighten all hardware. Repeat **Steps 1-8 and 10** for the other side Step Bar installation.

The installation is completed!!!



(Fig 16) Slide & line up the U-Slider with the installed mounting brackets along bottom channel

(2) M6X1-20mm Hex Bolts
(2) M6 Large Flat Washers
(2) M6 Lock Washers

IMPORTANT: TORQUE FOR 6MM FASTNERS MUST LESS THAN 6-7 FT-LBS OR THE FASTNERS WILL BE DAMAGED!



(Fig 17) Step Bar Installed on Bracket Installed (Example)

Attention

Do periodic inspections to the installation to make sure that all hardware is secure and tight.

In order to protect your bars/boards, please use only mild soap/non-abrasive products for cleaning.