

iBoard®

iBoard® by APS

PART#: IB-R176

READ INSTRUCTIONS CAREFULLY BEFORE STARTING INSTALLATION. REMOVE CONTENTS FROM BOX AND VERIFY ALL PARTS ARE PRESENT. ASSISTANCE IS RECOMMENDED.

*ROCKER PANEL MOUNT
*NO DRILLING REQUIRED

Fastener Size	Tightening Torque (ft-lbs)
6mm	6-7
8mm	16-18
10mm	31-32
12mm	56-58
14mm	92-94

PART LIST

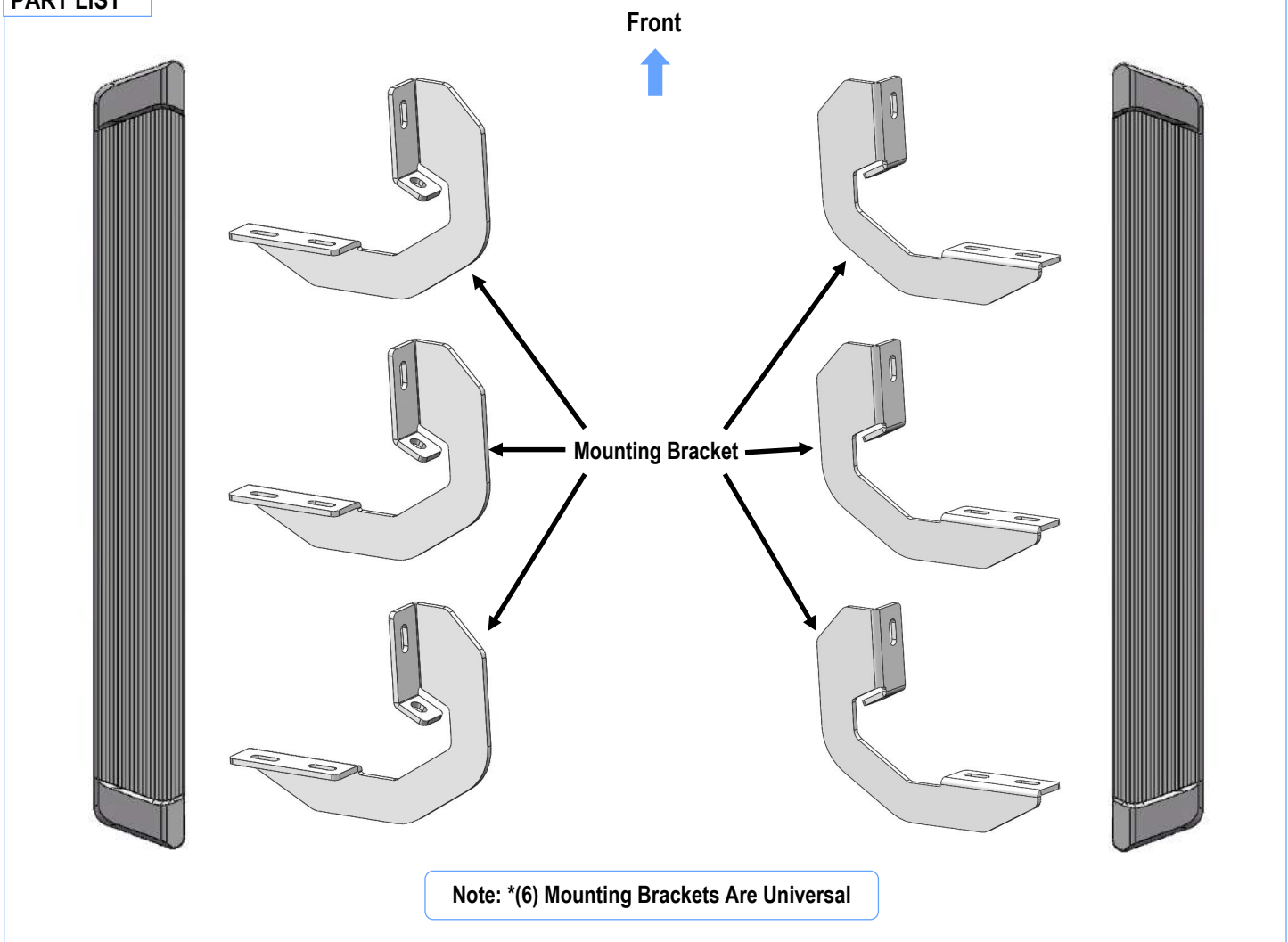

Customer Support: info@iboardauto.com

iBoard®

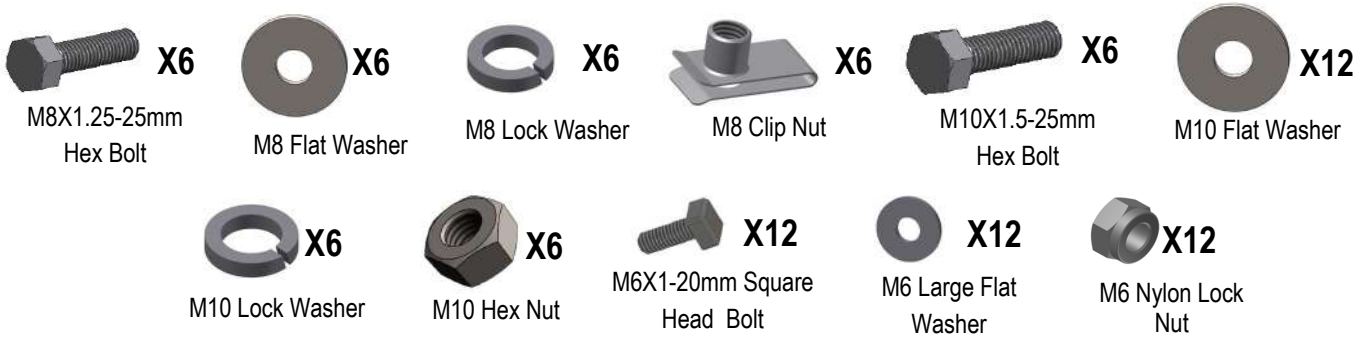

STEP 1

Starting on the passenger side of the vehicle. Locate mounting locations as shown, (Fig 1).

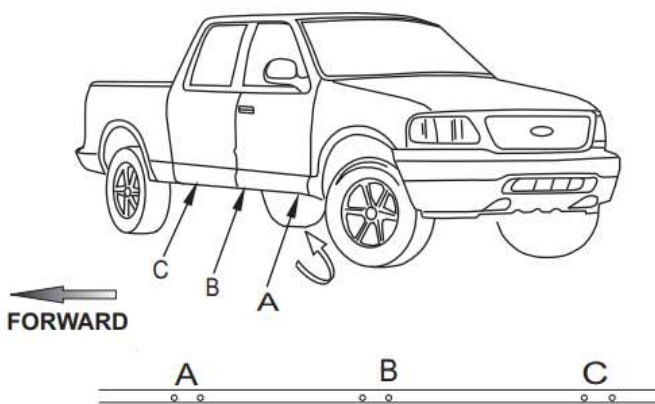

(Fig 1) Passenger Side Mounting Locations

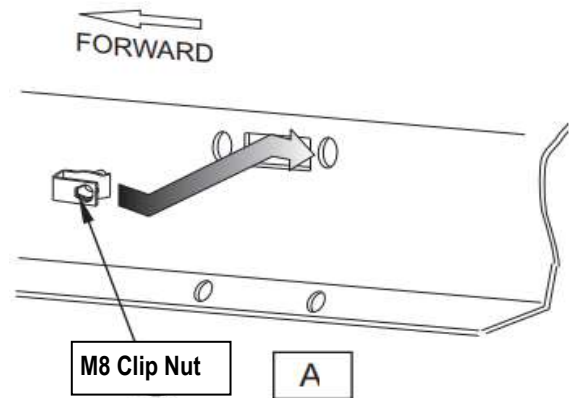

(Fig 2) Passenger Front Mounting Location

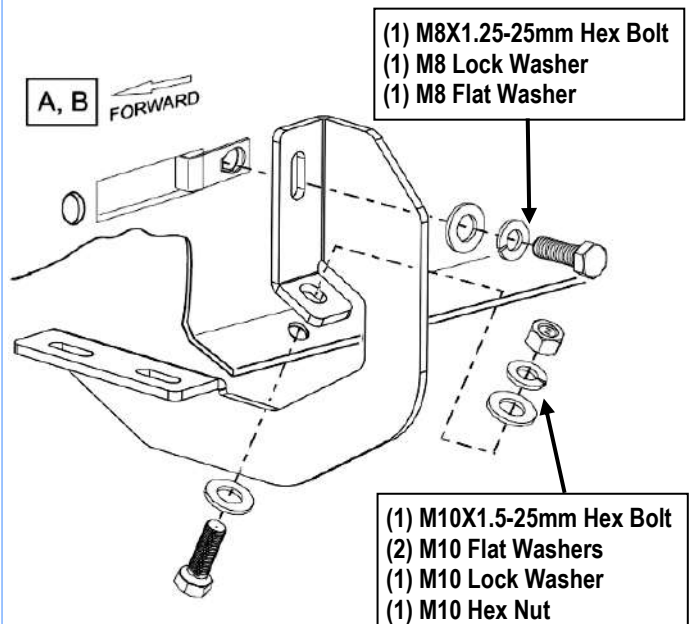

(Fig 3) Passenger Front Mounting Bracket Installation

STEP 2

Starting on the passenger side front of the vehicle. Select (1) M8 Clip Nut, install the M8 Clip Nut as shown, (Fig 2). Attach the Mounting Bracket to the installed M8 Clip Nut with (1) M8X1.25-25mm Hex Bolt, (1) M8 Lock Washer and (1) M8 Flat Washer; to rocker panel with (1) M10X1.5-25mm Hex Bolt, (2) M10 Flat Washers, (1) M10 Lock Washer and (1) M10 Hex Nut, (Figs 3-4). Do not fully tighten hardware at this time.

iBoard®

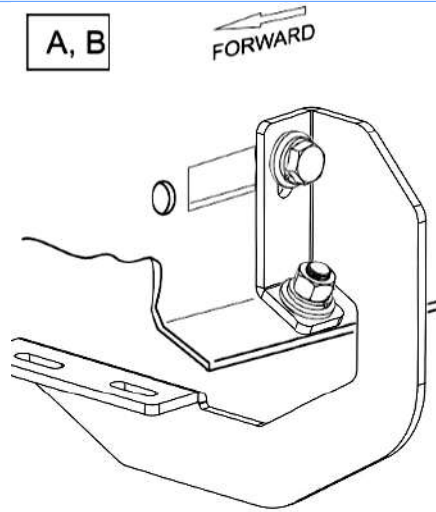

(Fig 4) Passenger Front Mounting Bracket Installation (Completely)

STEP 3

Move to the passenger side center & rear of the vehicle, repeat **Steps 1-2** for Passenger Center & Rear Mounting Bracket installation. Do not fully tighten hardware at this time.

Note: (6) Mounting Brackets Are Universal.

STEP 4

Select a Running Board. Slip (3) M6x1-20mm Square Head Bolts into each bottom channel (**Fig 5**). Carefully position the Running Board onto the (3) Mounting Brackets.

IMPORTANT: Do not slide the Running Board on the Brackets or the bottom surface of the board will be damaged. Attach the Running Board to each Mounting Bracket with (2) M6x1-20mm Square Head Bolts, (2) M6 Large Flat Washers and (2) M6 Nylon Lock Nuts (**Fig 6**). Do not fully tighten at this time.

M6X1-20mm Square Head Bolts

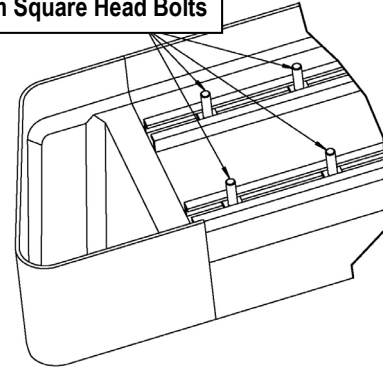

(Fig 5) Slip M6X1-20mm Square Head Bolts Into The Bottom Channels

(2) M6X1-20mm Square Head Bolts
(2) M6 Large Flat Washers
(2) M6 Nylon Lock Nuts

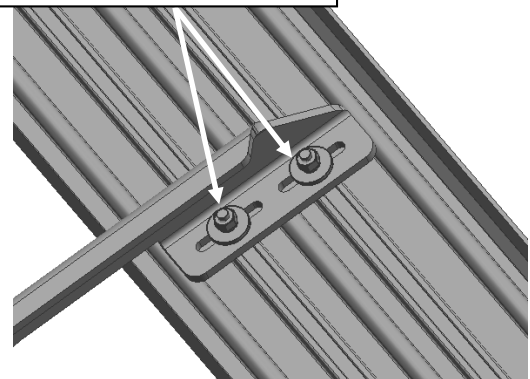

(Fig 6) Running Board Installed Onto Mounting Bracket

STEP 5

Level and adjust the Running Board and fully tighten all hardware.

Important: Please follow the recommended Tightening Torques shown in the table on page 1. Don't over tighten, or the nuts/bolts will be damaged.

iBoard®

STEP 6

Repeat **Steps 1-5** for the other side Running Board installation. The installation is completed (**Fig 7**).



(Fig 7) Installation Completed

Attention

Do periodic inspections to the installation to make sure that all hardware is secure and tight.

In order to protect your bars/boards, please use only mild soap/non-abrasive products for cleaning.