

# iBoard®

## iBoard® by APS

PART#: IB-106

READ INSTRUCTIONS CAREFULLY BEFORE STARTING INSTALLATION. REMOVE CONTENTS FROM BOX AND VERIFY ALL PARTS ARE PRESENT. ASSISTANCE IS RECOMMENDED.

\*ROCKER PANEL MOUNT  
\*NO DRILLING REQUIRED

Fastener Size	Tightening Torque (ft-lbs)	Required
6mm	6-7	√
8mm	16-18	√
10mm	31-32	X
12mm	56-58	X
14mm	92-94	X

### PART LIST

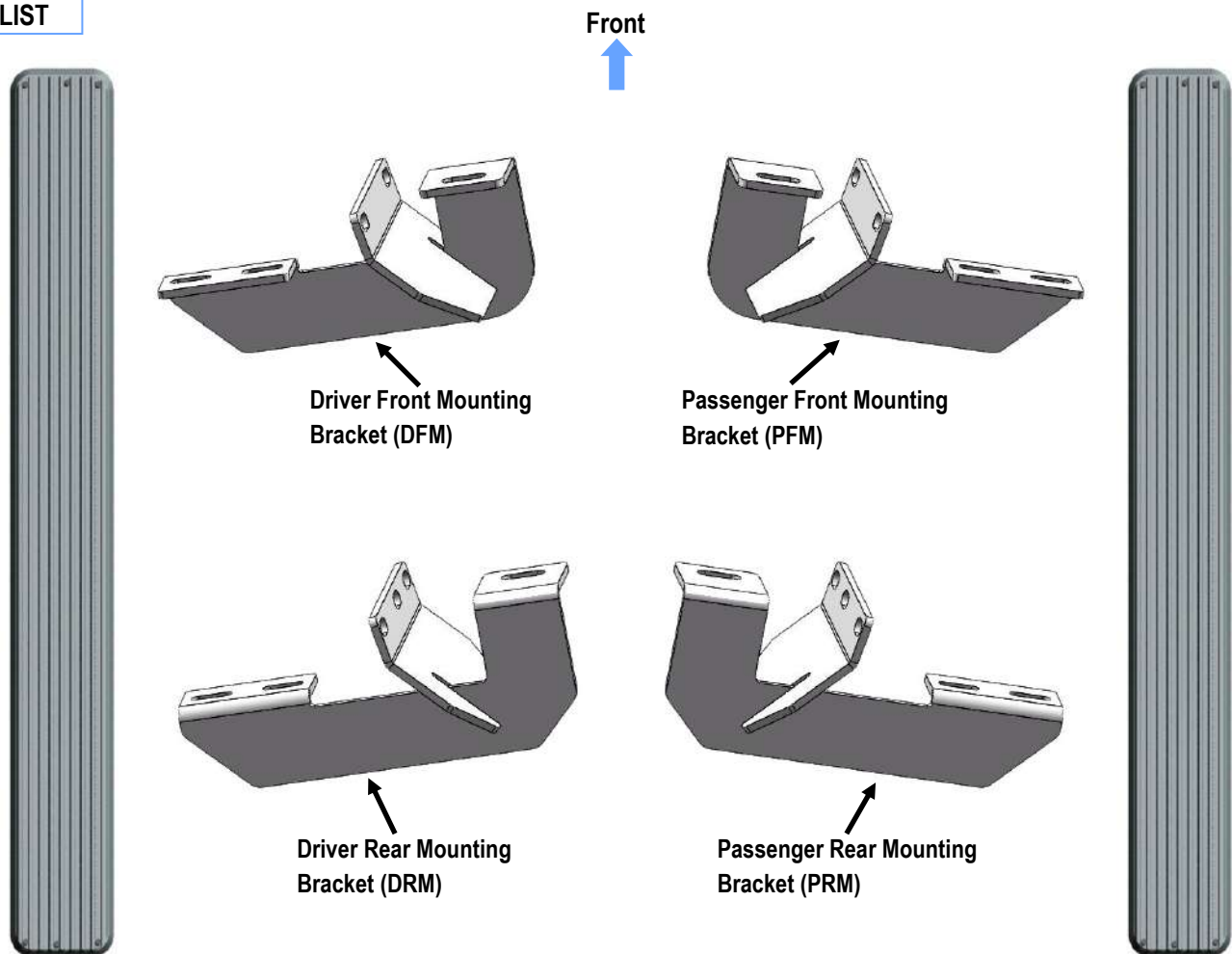

Customer Support: [info@iboardauto.com](mailto:info@iboardauto.com)

# iBoard®

## Hardware Package A (For Bracket Installation)



X4



X4



X4



X4



X8



X8



X8



X8

## Hardware Package B (For Aluminum Step Bar Installation Only, Not Supply to Stainless Steel Step Bar)



X8



X8



X8

## Hardware Package C (For Stainless Steel Step Bar Installation Only, Not Supply to Aluminum Step Bar)



X8



X8



X8

## STEP 1

Start installation toward the front of the driver side of the vehicle. Determine if the vehicle has an open floor panel or a threaded hole in the floor panel for the top tab on the Bracket, (Figs 1 & 3).

### Vehicles open mounting location:

Insert (1) M8 Nut Plate into the large square opening in the floor panel. Line up the threaded nut with the small hole in line with the tab on the Bracket, (Figs 2A & 2B). Bolt the Bracket to the Nut Plate with (1) M8X1.25-35mm Hex Bolt, (1) M8 Lock Washer and (1) M8 Large Flat Washer. Do not fully tighten hardware at this time, (Fig 4).

### Vehicles with factory threaded hole in floor panel:

Bolt the tab on the Bracket to the threaded hole in the floor panel with (1) M8X1.25-35mm Hex Bolt, (1) M8 Lock Washer and (1) M8 Large Flat Washer, (Figs 3 & 4). Do not fully tighten hardware at this time.

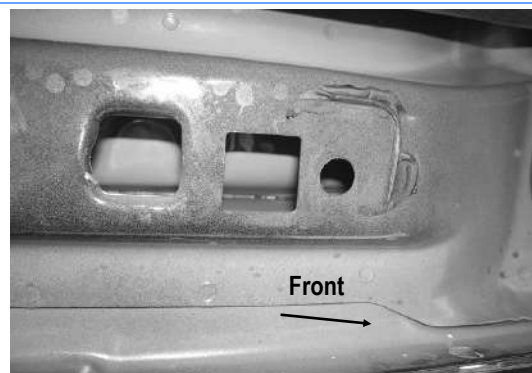

(Fig 1) Driver Side Front Mounting Location (Vehicles with open mounting location)

# iBoard®

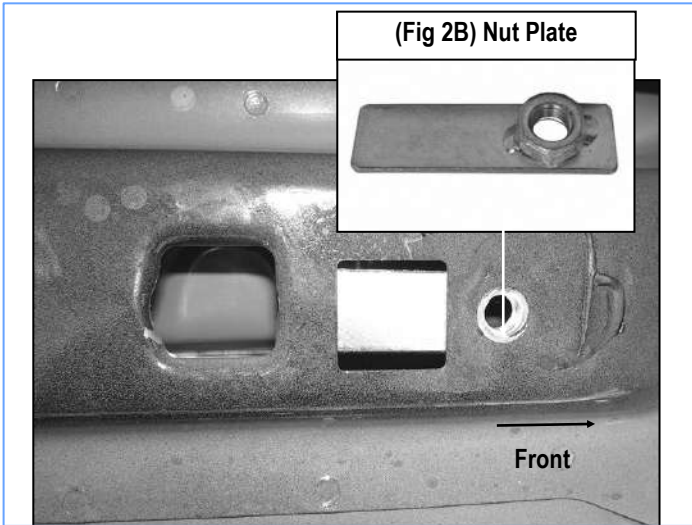

(Fig 2A) Driver Side Front Mounting Location  
(Vehicles with open mounting location)

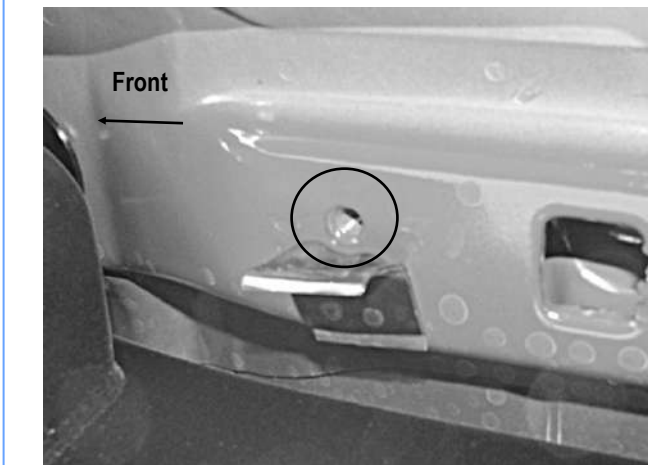

(Fig 3) Driver Side Front Mounting Location  
(Vehicles with factory threaded hole in floor panel)

## STEP 2

Line up the Support Bracket with the (2) factory holes on the pinch weld. Bolt the Support Bracket to the back of the pinch weld using the included (2) M6X1-25mm Inner Hex Bolts, (2) M8 Flat Washers, (against pinch weld), (2) M6 Large Flat Washers, (inside against the bracket) and (2) M6X1 Nylon Lock Nuts, (Fig 5). Do not fully tighten hardware at this time.

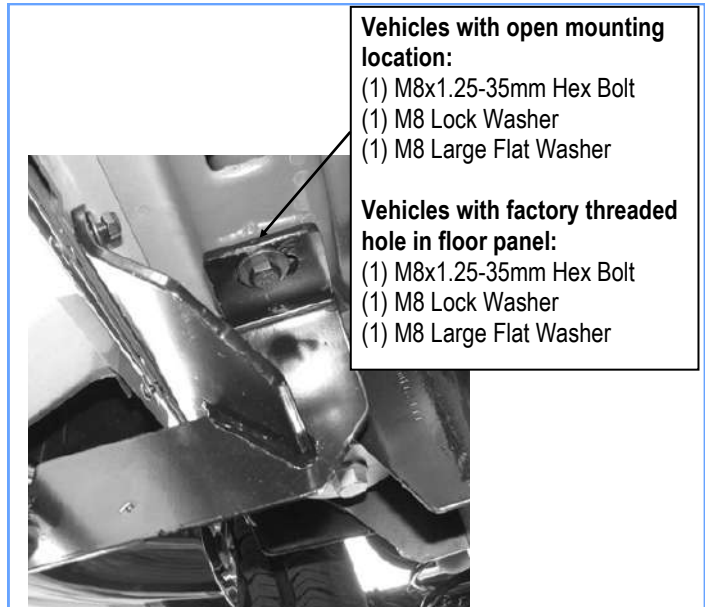

(Fig 4) Driver Front Mounting Bracket Installation

- (2) M6X1-25mm Inner Hex Bolts
- (2) M6 Flat Washers (against pinch weld)
- (2) M6 Large Flat Washers (inside against the bracket)
- (2) M6X1 Nylon Lock Nuts

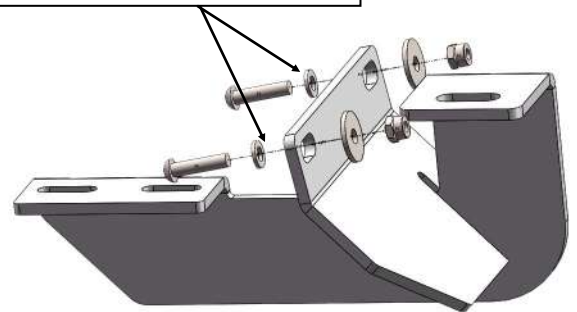

(Fig 5) Driver Front Support Bracket Installation

# iBoard®

## STEP 3

Move to the Driver Side Rear Mounting Location, (**Fig 6A**). Repeat **Steps 1-2** for Driver Rear Mounting Bracket (**DRM**) installation, (**Figs 3 & 6A & 6B**).

**NOTE:** Determine correct Rear Support Bracket installation procedure according to the model year of the vehicle:

**A. 2007 Model:** Line up the center hole on the Support Bracket to the pinch weld, secure by using (1) M6X1-25mm Inner Hex Bolt, (1) M6 Flat Washer (outside) and (1) M6 Large Flat Washer, (inside against bracket), and (1) M6X1 Nylon Lock Nut to attach rear bracket to the back of the pinch weld, (**Figs 7 & 8**).

**B. 2008-UP Models:** Requires (2) M6X1-25mm Inner Hex Bolts, (2) M6 Flat Washers, (outside), (2) M6 Large Flat Washers, (inside against the bracket) and (2) M6X1 Nylon Lock Nuts to attach rear bracket to back of pinch weld, (**Figs 7 & 9**).

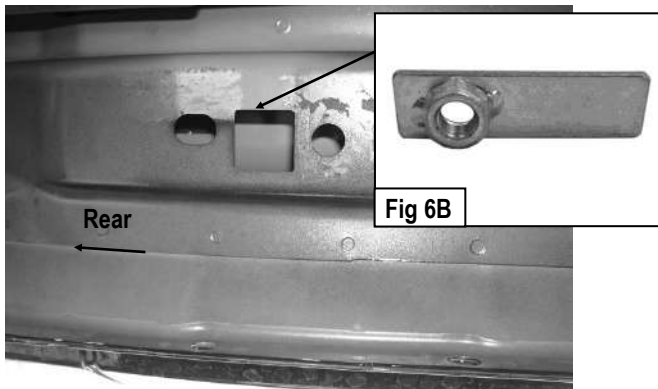

(Fig 6A) Driver Side Rear Mounting Location (Vehicles with open mounting location)

2007 model uses (1) M6 Bolt in center hole

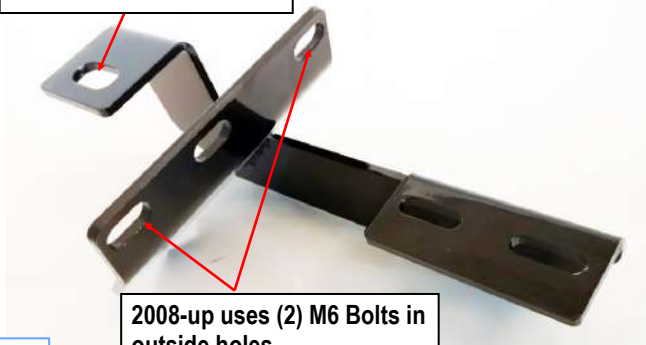
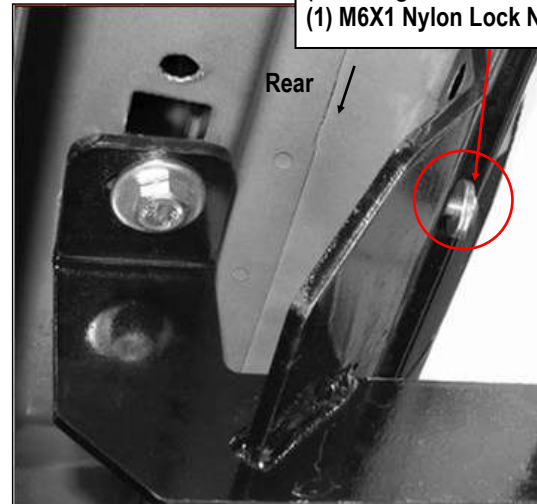

Fig 7

2008-up uses (2) M6 Bolts in outside holes

2007 Model Uses:

- (1) M6X1-25mm Inner Hex Bolt
- (1) M6 Flat Washers (outside)
- (1) M6 Large Flat Washer (inside against the bracket)
- (1) M6X1 Nylon Lock Nut



(Fig 8) Driver Rear Support Bracket Installation (For 2007 Model Only)

2008-UP Models Uses:

- (2) M6X1-25mm Inner Hex Bolts
- (2) M6 Flat Washers (outside)
- (2) M6 Large Flat Washers (inside against the bracket)
- (2) M6X1 Nylon Lock Nuts

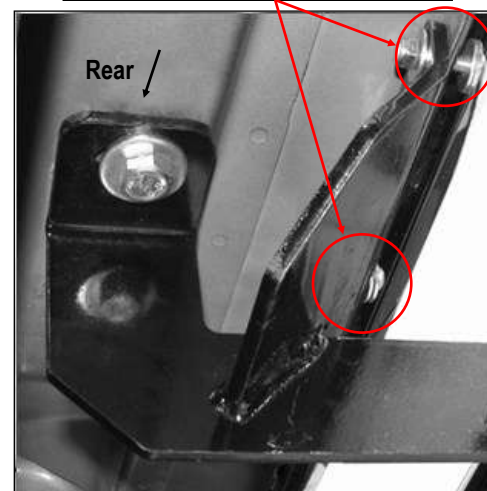

(Fig 9) Driver Rear Support Bracket Installation (For 08-UP Models)

# iBoard®

## STEP 4

Once all (2) mounting brackets are installed, then proceed to the Step Bar installation. According to the style of Step Bar proceed to the correct installation STEPS.

**Note:** Aluminum Step Bar refer to STEP 5; Stainless Steel Step Bar skip to STEP 6.

## STEP 5

### Aluminum Step Bar Installation:

Select a **Aluminum Step Bar**. Slip (2) M6x1-20mm Square Head Bolts into each bottom channel (**Fig 10**). Carefully position the Step Bar onto the (2) Mounting Brackets.

**IMPORTANT:** Do not slide the Step Bar on the Brackets or the bottom surface of the board will be damaged. Attach the Step Bar to each Mounting Brackets with (2) M6x1-20mm Square Head Bolts, (2) M6 Large Flat Washers and (2) M6X1 Nylon Lock Nuts, (**Fig 11**). Do not fully tighten at this time.

Level and adjust the Step Bar and fully tighten all hardware. Repeat **Steps 1-5** for the other side Step Bar installation. **The installation is completed!!!**



(Fig 10) Slip M6X1-20mm Square Head Bolts Into The Bottom Channels

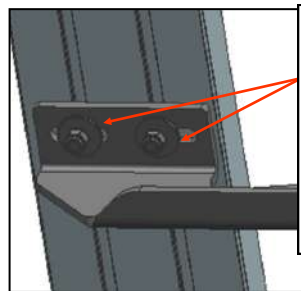

(2) M6X1-20mm Square Head Bolts  
(2) M6 Large Flat Washers  
(2) M6X1 Nylon Lock Nuts  
**IMPORTANT: TORQUE FOR 6MM FASTNERS MUST LESS THAN 6-7 FT-LBS OR THE FASTNERS WILL BE DAMAGED!**

(Fig 11) Running Board Installed Onto Mounting Bracket

## STEP 6

### Stainless Steel Step Bar Installation:

Select a **Stainless Steel Step Bar** (with the U-Sliders installed on the Bar). Loose the U-Sliders, reposition the U-Sliders onto the board according to the (2) Installed Mounting Brackets location, (**Fig 12**). Re-secure the U-Sliders on the Step Bar. Attach the Step Bar to the installed Mounting Brackets with (4) M6X1-20mm Hex Bolts, (4) M6 Large Flat Washers & (4) M6 Lock Washers, (**Fig 13**). Do not fully tighten hardware at this time.

Level and adjust the Step Bar and fully tighten all hardware.

Repeat **Steps 1-4 and 6** for the other side Step Bar installation.

**The installation is completed!!!**



(Fig 12) Slide & line up the U-Slider with the installed mounting brackets along bottom channel

# iBoard®

- (2) M6X1-20mm Hex Bolts
- (2) M6 Large Flat Washers
- (2) M6 Lock Washers

**IMPORTANT: TORQUE FOR 6MM FASTNERS MUST LESS THAN 6-7 FT-LBS OR THE FASTNERS WILL BE DAMAGED!**

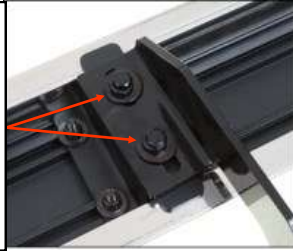

(Fig 13) Step Bar Installed on Bracket Installed (Example)

### Attention

Do periodic inspections to the installation to make sure that all hardware is secure and tight.

In order to protect your bars/boards, please use only mild soap/non-abrasive products for cleaning.