

PARTS LIST:

1	85" Driver/left side Running Board	17	8-1.25mm x 25mm Hex Bolts
1	85" Passenger/right side Running Board	8	8mm x 35mm Double Bolt Plates
1	Passenger/right Front Upper Bracket (all incl. DEF)	33	8mm x 24mm x 2mm Flat Washers
1	Passenger/right Front Lower Bracket (all incl. DEF)	17	8mm Lock Washers
7	Mounting Brackets (use for left or right)	1	8-1.25mm Bolt Plate
15	8-1.25mm Clip-On Nuts	17	8mm Nylon Lock Nuts

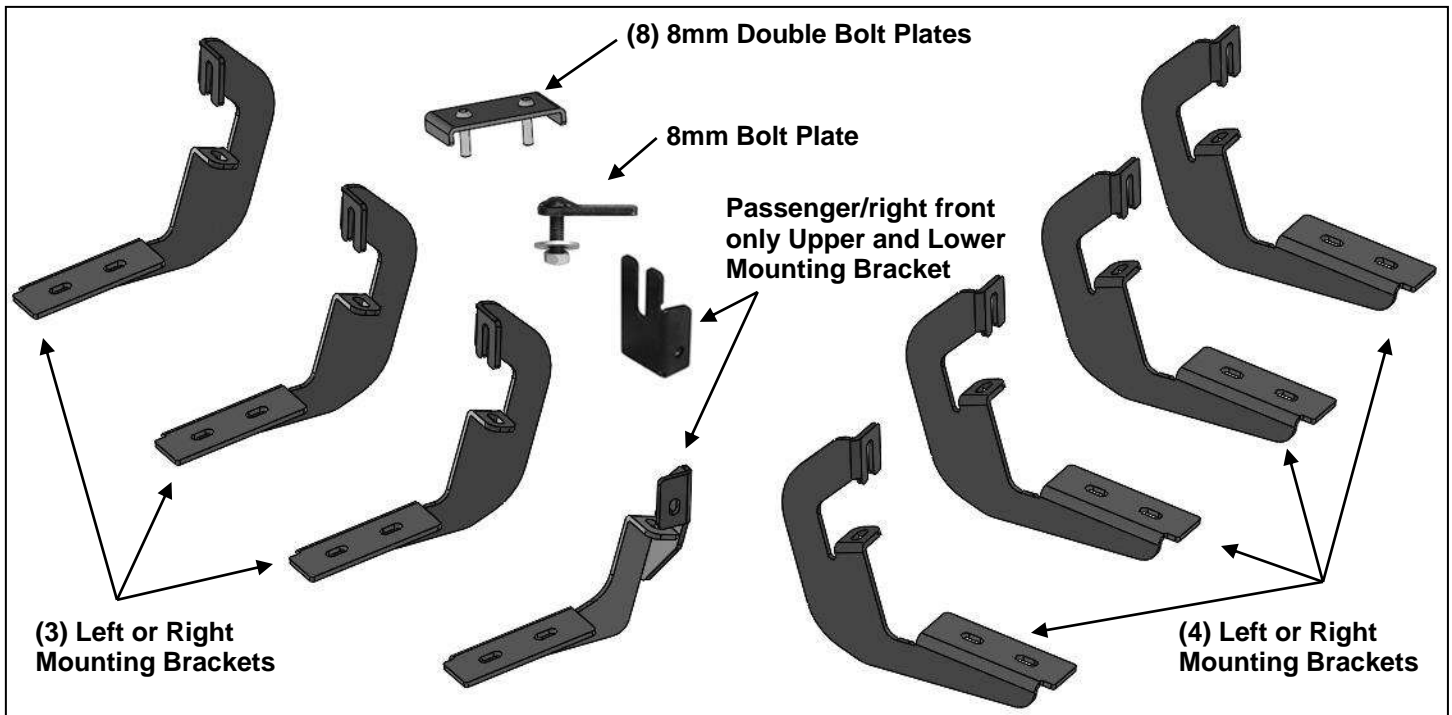

PROCEDURE:

REMOVE CONTENTS FROM BOX. VERIFY ALL PARTS ARE PRESENT. READ INSTRUCTIONS CAREFULLY BEFORE STARTING INSTALLATION. ASSISTANCE IS RECOMMENDED. ON MODELS WITH DEF TANK, SELECT A FLAT, LEVEL AREA FOR INSTALLATION. MAY REQUIRE CUTTING.

1. Start the installation under the driver side of the vehicle. Locate the 5 tabs along the bottom edge of the body, (pinch weld). Mounting Brackets will bolt to the 1st, 2nd, (just in front of center of cab), 4th and 5th mounting tabs, **(Figure 1)**. Directly above each tab is a top mounting location on the side of the body panel. Hold a Bracket up in place to help determine the mounting holes to use along the body.
2. Determine the correct procedure for your model year and each Bracket location.

Bottom mounting location on the edge of the pinch weld.

Flat tab on pinch weld with factory installed weld nut:

Thread hex bolt into weld nut from the backside-down to clear paint from threads, **(Figure 2)**.

Flat tab on pinch weld with hole:

Select (1) 8mm Clip Nut. Slide the Clip Nut over the tab with the nut facing up behind the tab, **(Figures 3—6)**. Line up threaded nut with hole in the tab. Repeat for each mounting location.

Locate top mounting location on the back side of the body panel.

Models with factory installed threaded insert in body panel:

Thread 8mm Hex Bolt into threaded insert to clear paint as required, **(Figures 2 & 3)**.

Large and small hole in side of body panel:

Remove the rubber plug from the larger hole, **(Figures 4 & 5)**. Select (1) 8mm Clip Nut. Slide the Clip Nut into the larger hole. Line up the threaded nut with the smaller hole, **(Figure 6)**.

3. Select (1) Mounting Bracket. **NOTE:** (7) Brackets are universal and will fit all left or center and rear right side. Bolt the Mounting Bracket to the Clip Nuts and/or the factory threaded holes with (2) 8mm Hex Bolts, (2) 8mm Lock Washers and (2) 8mm Flat Washers, (**Figures 7 & 8**). Do not tighten hardware.
4. Repeat **Steps 1—3** to install the (3) remaining driver side Brackets.
5. Select (1) Running Board. Place the Running Board on top of the Brackets. Locate the channels in the bottom of the Running Board. Select (4) 8mm Double Bolt Plates, (**Figure 9**). Insert the Bolt Plates into the channels in the bottom of the Running Board closest to the Brackets, (**Figure 10**). Lift the Running Board up and guide the studs through the Brackets.
6. Attach the Running Board to the Brackets with (8) 8mm Flat Washers and (8) 8mm Nylon Lock Nuts, (**Figures 11 & 24**). **NOTE:** The Running Board is designed to fit close to the vehicle. It may be necessary to loosen the Bracket hardware and tilt the Brackets downward to insert the Running Board between the Brackets and the body. Do not tighten hardware at this time.
7. Level and adjust the Running Board and fully tighten all hardware.
8. Move to the passenger side of the vehicle. On the passenger side, determine if the vehicle is equipped with a plastic diesel exhaust fluid (DEF) tank, (**Figures 12 & 13**).

Models without DEF tank, skip to Step 9.

Models with DEF tank: The tank sits close to the side of the body. With specialized tools, the passenger front upper and lower Bracket can be installed but room is very limited. Determine model year of vehicle before proceeding.

Up to 2016 models:

It may be easier to drop the tank down to access the inner side of the body panel for upper bracket installation. Tank will not need to be removed, only dropped down for access to mounting location.

IMPORTANT: If tank is full, it will be very heavy and assistance is highly recommended to avoid injury or damage to the vehicle or the tank. It is recommended that installation is performed when the DEF tank is low on fluid before dropping the tank.

- a. On models with plastic lower tray under the tank, remove the (3) hex bolts attaching the tray to the frame, (**Figure 12**), and remove the tray.
- b. Release the tank filler hose. Release the plug for the sending unit on the top of the tank.
- c. Support the tank with a floor jack. Place a smooth flat surface, (wooden block for example), between the floor jack and the tank to avoid damaging the plastic tank. Do not push up on the tank; only support the weight of the tank with the jack.
- d. Remove the (2) bolts securing the tank straps to the vehicle, (**Figure 13**). Tilt the straps to release from the brackets. Slowly lower the tank until the top of the tank is almost visible. Use blocks or stands to support the tank while installing the front Upper and Lower Brackets.
- e. Proceed to **Step 9**.

On 2017 models and on:

- a. Remove the (4) hex bolts attaching plastic cover to DEF tank, (**Figure 14A**) and remove plastic cover, (**Figure 14B**). **NOTE:** On 2017-on 2500/3500 models, only remove plastic cover from DEF tank. Do not lower DEF tank and proceed to **Step 9**.
9. Locate the first tab on the edge of the pinch weld, (**Figures 2—5, 16 & 18**). Select the Upper Bracket, (**Figure 15**). Repeat **Steps 2 & 3** to attach the passenger front Upper Bracket to the side of the body panel, (**Figure 16**). Do not tighten hardware at this time.
10. Line up the hole in the bottom of the Upper Bracket with the hole in the tab on the pinch weld.
 - a. **Models with a weld-nut:** Slide the Bracket over the weld-nut, (**Figure 16**). Attach the Lower Bracket to the bottom of the body and weld-nut with (1) 8mm x 25mm Hex Bolt, (1) 8mm Lock Washer and (1) 8mm Flat Washer, (**Figures 19 & 24**). Leave loose at this time.
 - b. **Models with flat tab and hole:** Insert the 8mm Bolt Plate down through the hole in the Upper Bracket and mounting tab, (**Figures 17 & 18**). Attach the Lower Bracket to the bottom of the body and Bolt Plate with (1) 8mm Flat Washer and (1) 8mm Nylon Lock Nut, (**Figures 19 & 23**). Leave loose at this time.
11. Line up the side tab on the Lower Bracket with the threaded hole in the side of the Upper Bracket. Attach the Lower Bracket to the Upper Bracket with (1) 8mm x 25mm Hex Bolt, (1) 8mm Lock Washer and (1) 8mm Flat Washer, (**Figure 24**). Leave loose at this time.

12. Repeat **Steps 1—3** for the (3) remaining passenger side Bracket installations. **NOTE:** Cradles on Brackets installed on passenger side will face forward.
 - a. **2017-on 2500/3500 DEF tank models:** Locate the 2nd tab bracket location along the bottom edge of the body, (pinch weld), (**Figure 20**). Hold the DEF cover in place and mark the location onto the cover, (**Figure 21**). Use a sharp knife or hacksaw blade to carefully cut a slot in the plastic cover to clear the 2nd Bracket, (**Figure 22**). Remove as little plastic as possible.
13. Repeat **Steps 5—7** to install the passenger side Running Board.
14. Once the Running Board has been installed and all hardware fully tightened, reinstall the DEF tank and cover, if equipped, as described in **Steps 8 & 12**.
15. Do periodic inspections to the installation to make sure that all hardware is secure and tight.

To protect your investment, wax this product after installing. Regular waxing is recommended to add a protective layer over the finish. Do not use any type of polish or wax that may contain abrasives that could damage the finish. Aluminum polish may be used to polish small scratches and scuffs on the finish. Mild soap may be used also to clean the Running Boards.

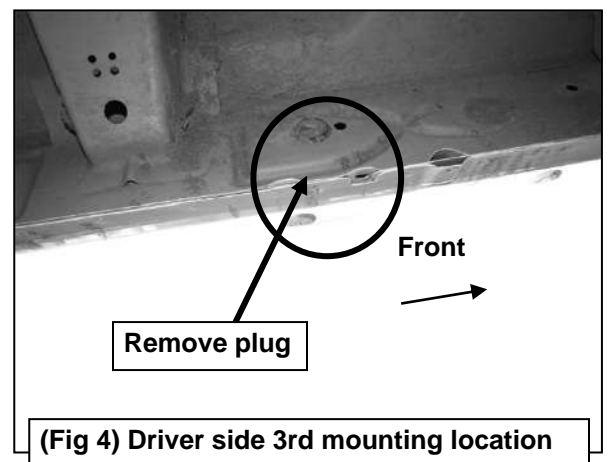
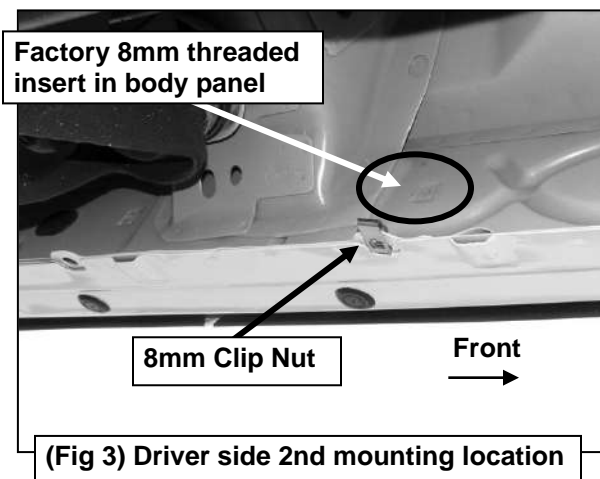
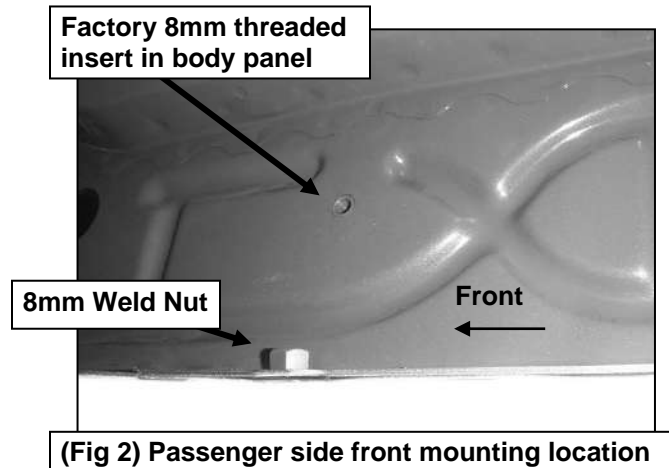
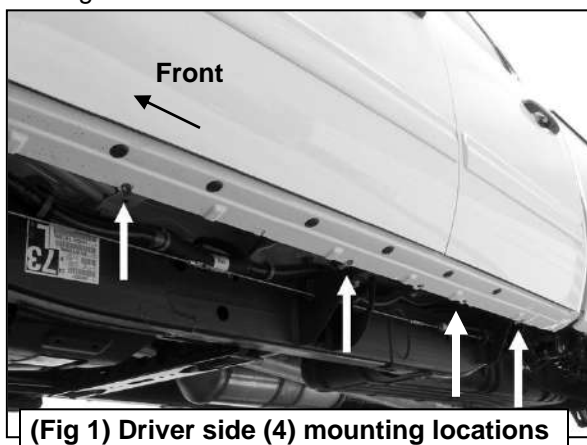

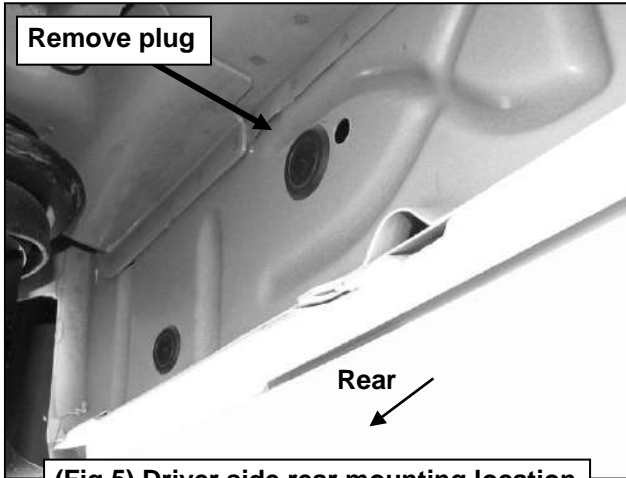

(Fig 5) Driver side rear mounting location

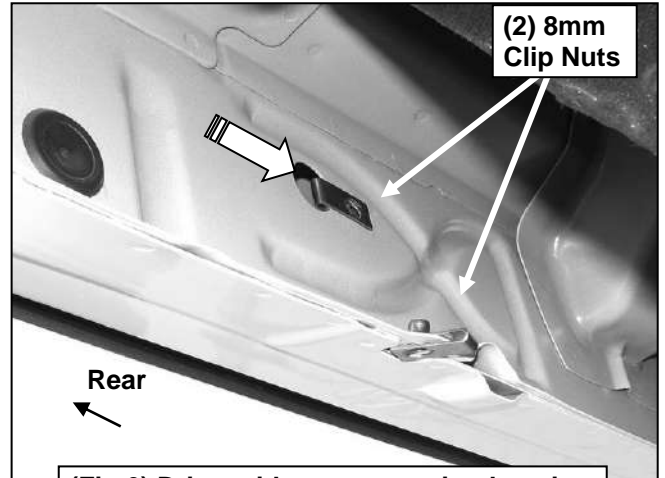

(Fig 6) Driver side rear mounting location

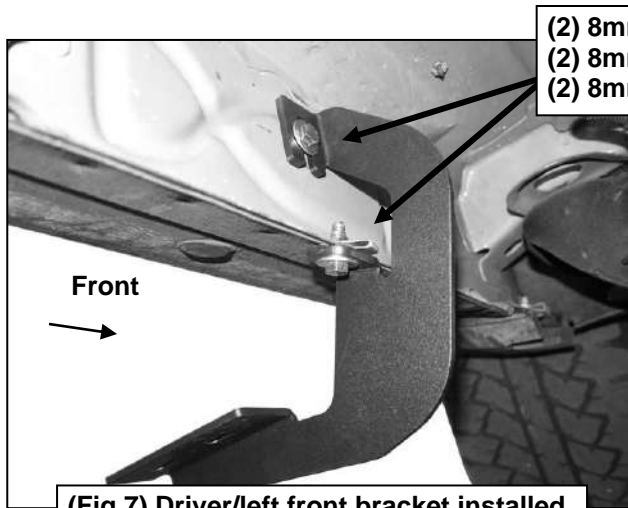

(Fig 7) Driver/left front bracket installed

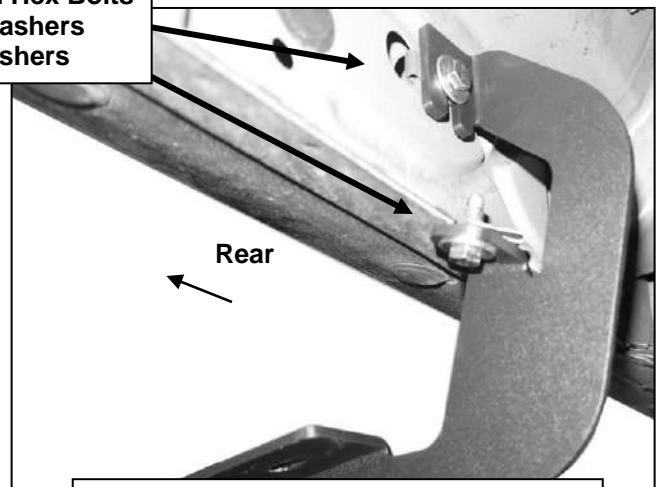

(Fig 8) Driver/left rear bracket installed

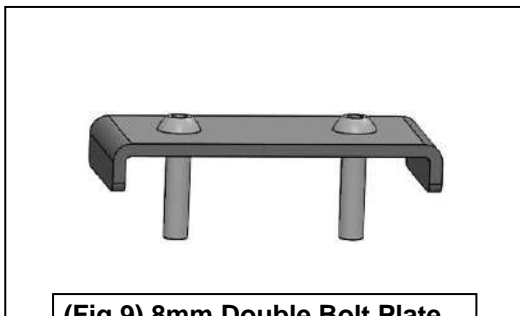

(Fig 9) 8mm Double Bolt Plate

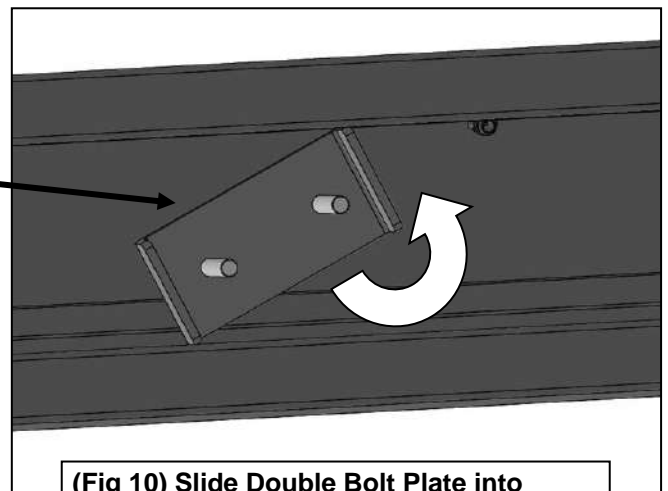

(Fig 10) Slide Double Bolt Plate into channel on the bottom of Running Board

Driver/Left Side Installation Pictured

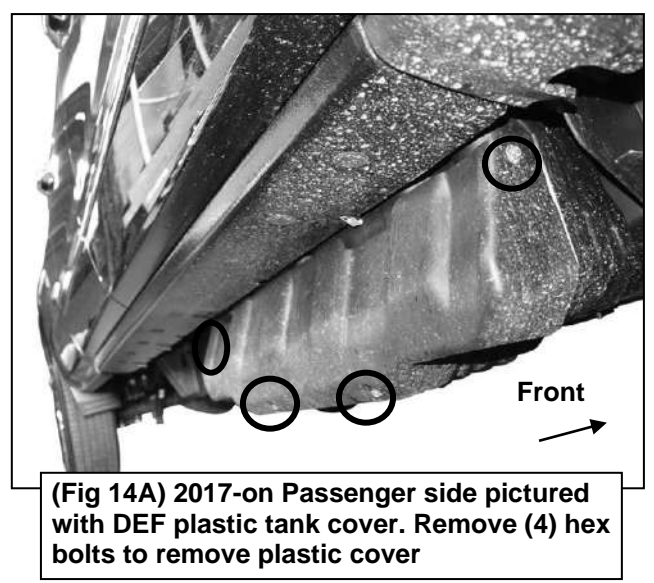
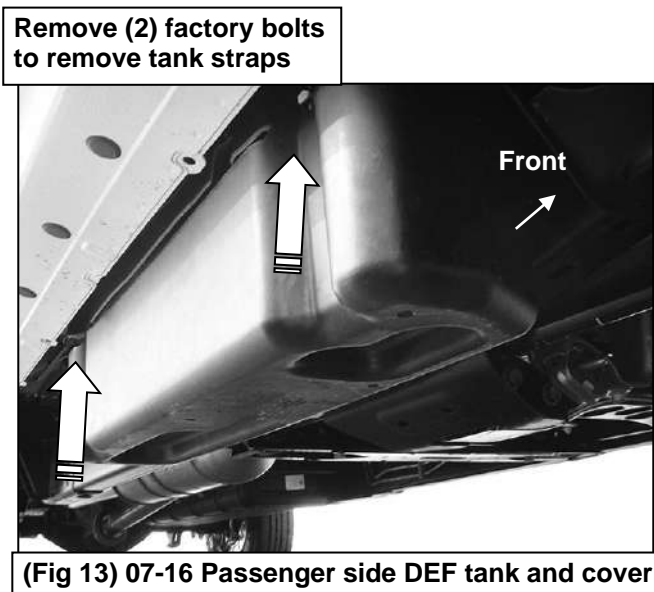
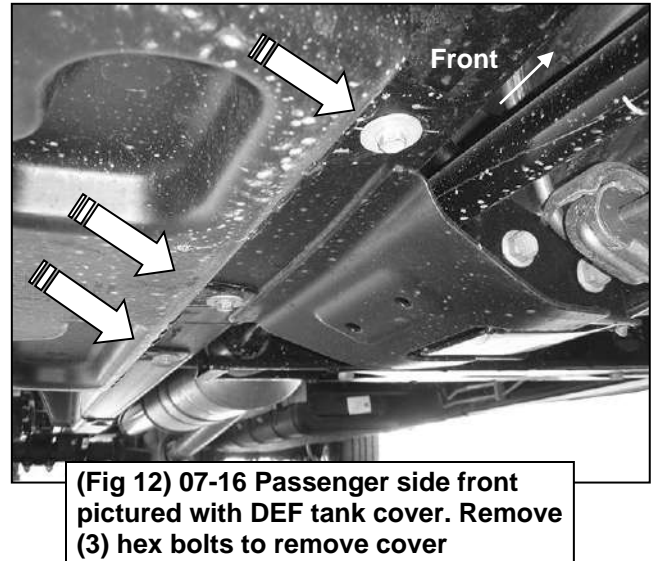
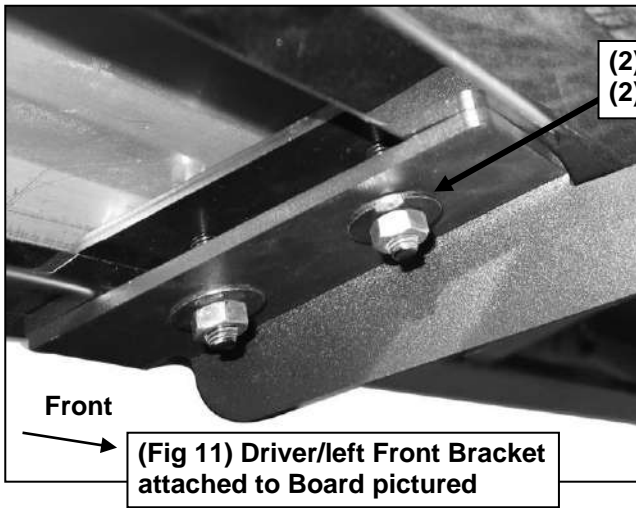

Passenger Side/Right Installation Pictured

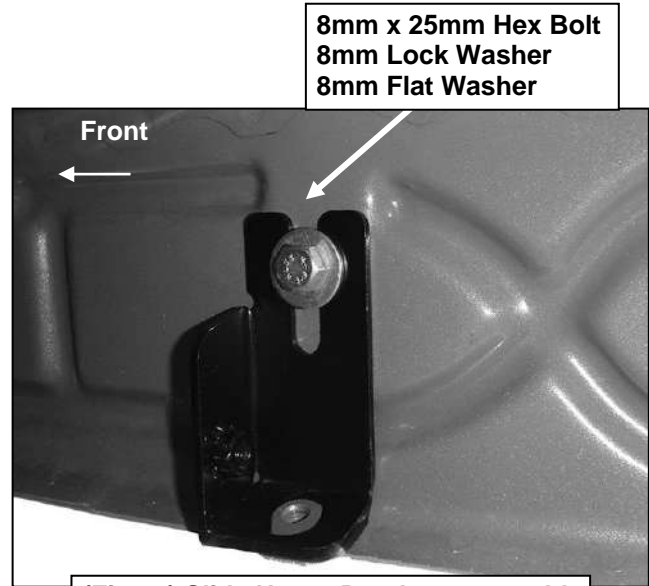
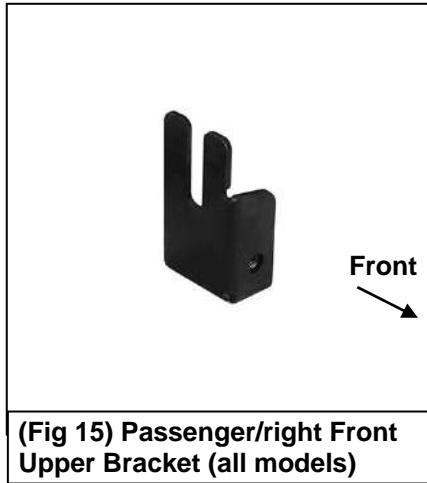

On models with flat tab (see Fig 3 & 4), insert 8mm Bolt Plate (Fig 16) down through Upper Bracket and mounting tab

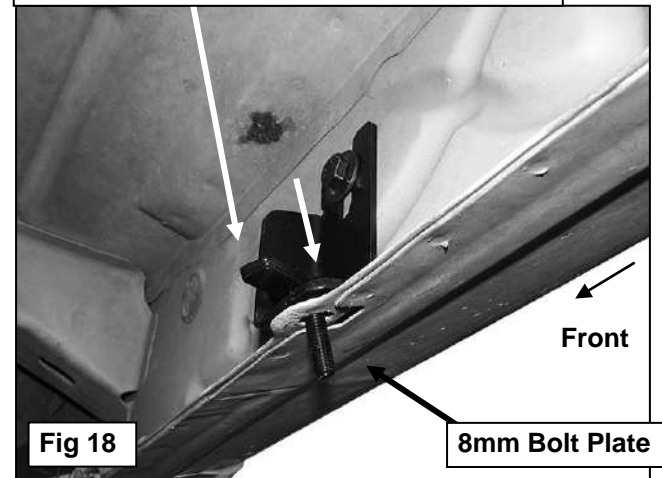
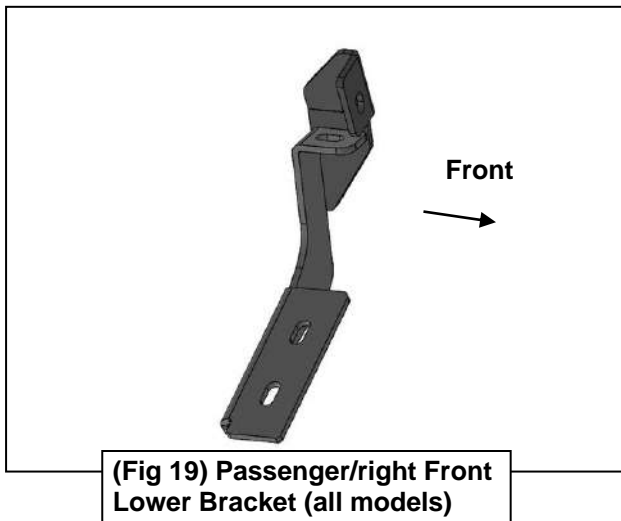

Passenger Side/Right Installation Pictured

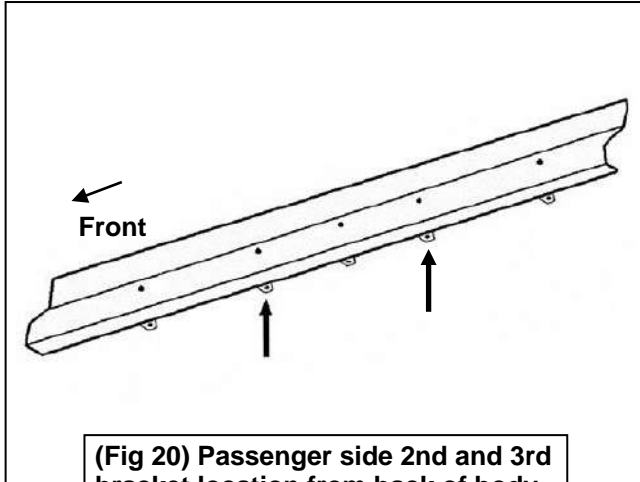

(Fig 20) Passenger side 2nd and 3rd bracket location from back of body

(Fig 21) 2017-on Passenger side DEF cover marked for trimming

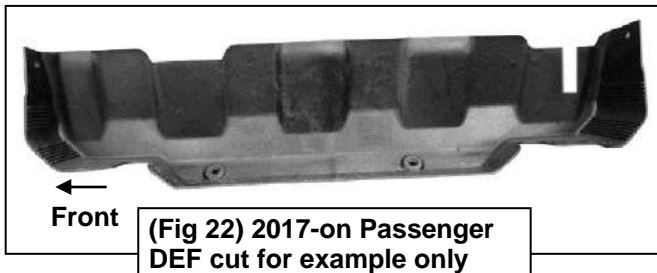

(Fig 22) 2017-on Passenger DEF cut for example only

On models with flat tab and 8mm Bolt Plate (see Fig. 17) use:
 8mm Flat Washer
 8mm Nylon Lock Nut
 to attach Lower Bracket to Bolt Plate

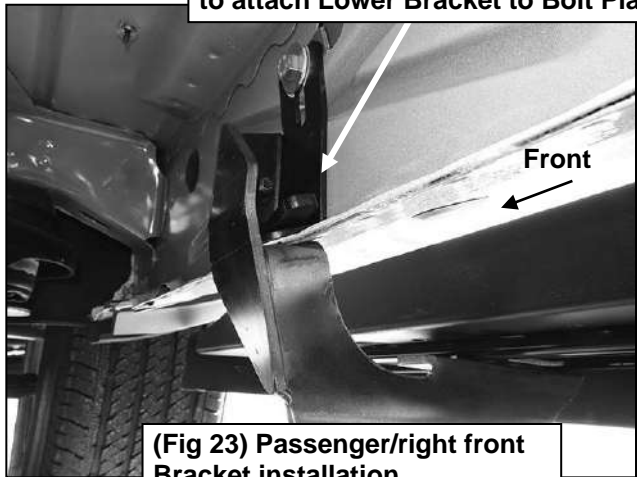

(Fig 23) Passenger/right front Bracket installation

All models use:
 8mm x 25mm Hex Bolt
 8mm Lock Washer
 8mm Flat Washer

Models with weld nut on tab (see Fig. 15) use:
 8mm x 25mm Hex Bolt
 8mm Lock Washer
 8mm Flat Washer



(Fig 24) Passenger/right side front Bracket attached to Running Board

(2) 8mm Flat Washers
 (2) 8mm Nylon Lock Nuts