

PARTS LIST:

1	Driver/Left Running Board	4	8mm Bolt/Nut Plates
1	Passenger/Right Running Board	4	8mm Plastic Retainers
2	Driver/Left Mounting Brackets	16	8mm x 24mm x 2mm Flat Washers
2	Passenger/Right Mounting Brackets	8	8mm Lock Washers
2	Driver/Left Support Brackets	4	8mm Hex Nuts
2	Passenger/Right Support Brackets	4	8mm Nylon Lock Nuts
8	10-1.5mm x 35mm Hex Bolts	8	6-1.0mm x 25mm Hex Bolts
16	10mm x 27mm x 3mm Flat Washers	16	6mm x 22mm x 2mm Flat Washers
8	10-1.5mm Nylon Lock Nuts	8	6mm Nylon Lock Nuts
12	8-1.25mm x 30mm Hex Bolts		

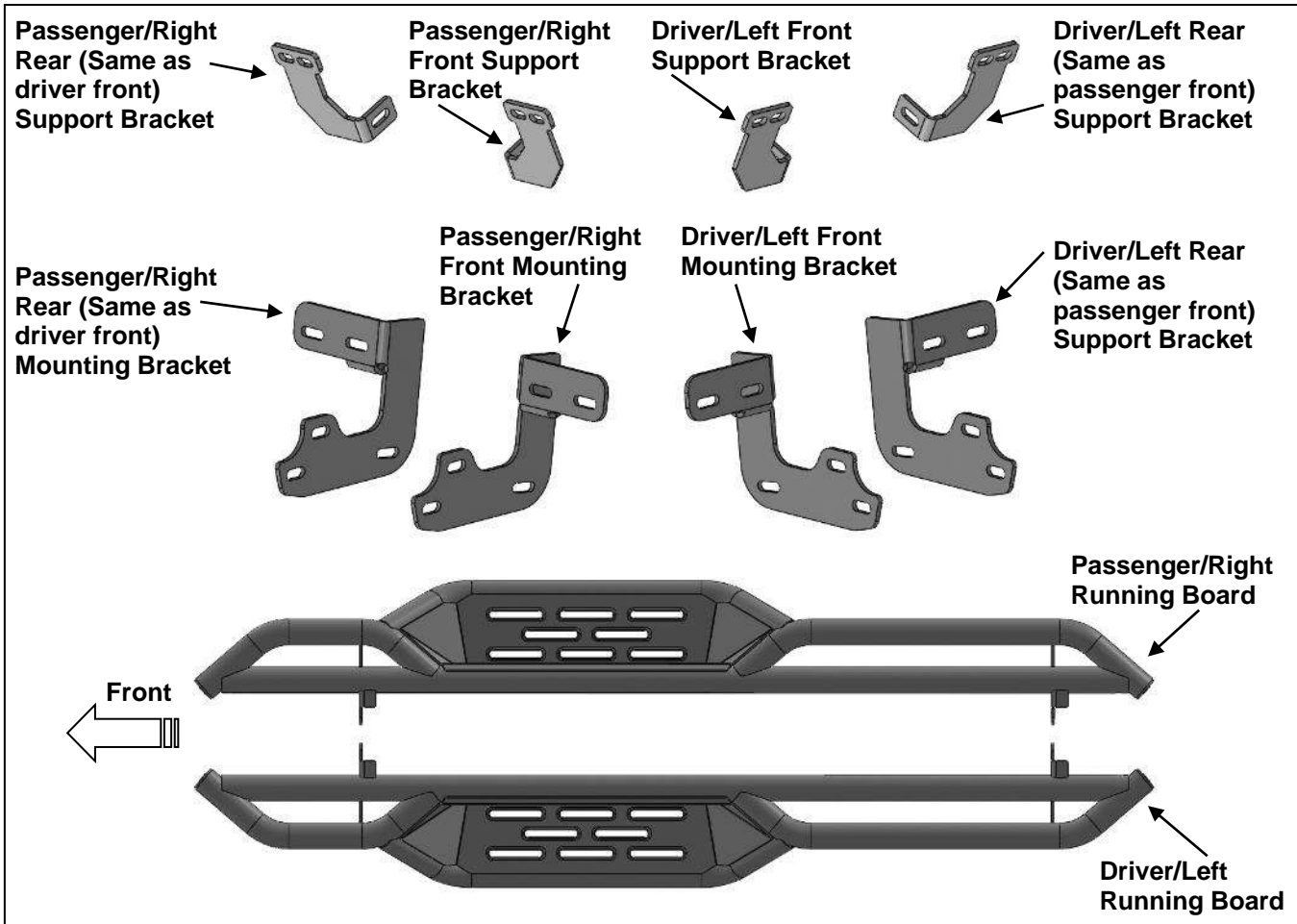

PROCEDURE:

- 1. REMOVE CONTENTS FROM BOX. VERIFY ALL PARTS ARE PRESENT. READ INSTRUCTIONS CAREFULLY BEFORE STARTING INSTALLATION. DRILLING MAY BE REQUIRED.**
- Starting at the Driver/Left front of the vehicle, remove the sealing tape covering the factory holes in the side of the inner panel, **(Figure 1)**.
- Determine the correct procedure to attach the Driver/Left Front Bracket for your model/year:
Models without factory threaded inserts in body panel:
 - Partially thread an 8mm Hex Bolt into the threaded end of an 8mm Bolt/Nut Plate. Thread the Hex Bolt in until it is flush with the welded nut, **(Figures 3 & 4)**. Use the Hex Bolt as a handle and insert the Bolt/Nut Plate into the oval hole, **(Figure 5)**. Feed the threaded bolt on the Bolt/Nut Plate through one of the hex shaped factory holes. Thread (1) 8mm Plastic Retainer onto the threaded end and down tight against the rocker

panel, **(Figure 6)**. **NOTE:** The Plastic Retainer is designed to keep the Bolt/Nut Plate from falling into the body panel and to aid in Bracket installation.

- b. Select (1) Driver/Left Mounting Bracket. Attach the bracket to the threaded end of the Bolt/Nut Plates on the Driver/Left Front mounting location with (1) 8mm Flat Washers, (1) 8mm Lock Washers and (1) 8mm Hex Nuts, **(Figure 7)**. Do not tighten at this time.
- c. Remove the 8mm Hex Bolt from the nut on the Bolt/Nut Plate from **Step 3a**. Rotate the Bolt on the Bolt/Nut Plate until the threaded nut lines up with the remaining hole in the Mounting Bracket and body panel. Attach the Bracket to the threaded Nut with (1) 8mm x 30mm Hex Bolt, (1) 8mm Lock Washer and (1) 8mm Flat Washer, **(Figure 8)**.

Models with factory threaded inserts:

- d. Attach (1) Driver/Left Mounting Brackets to the threaded inserts with (2) 8mm x 30mm Hex Bolts, (2) 8mm Lock Washers and (2) 8mm Flat Washers, **(Figures 9 & 10)**. Do not tighten.
4. Select the Driver/Left Front Support Bracket. Attach Bracket to the back of the pinch weld. Line up the slots in the top of the Support Bracket with the (2) factory holes in the pinch weld. Attach the Bracket to the back of the pinch weld with (2) 6mm x 25mm Hex Bolts, (4) 6mm Flat Washers and (2) 6mm Nylon Lock Nuts, **(Figure 11)**. **IMPORTANT:** 2009-12 models may not be equipped with factory holes and will require drilling through the pinch weld to attach the Support Bracket. Do not drill through pinch weld at this time, **(see Step 9)**.
 5. Attach the Support Bracket to the front facing side of the front Mounting Bracket with (1) 8mm x 30mm Hex Bolt, (2) 8mm Flat Washers and (1) 8mm Nylon Lock Nut, **(Figure 12)**. Do not tighten.
 6. Repeat **Steps 2—5** to attach the Driver/Left Rear Mounting Bracket and Support Bracket to the rocker panel and the pinch weld, **(Figure 2)**.
 7. Select the Driver/Left Running Board. Attach the Running Board to the front face of the mounting brackets with (4) 10mm x 35mm Hex Bolts, (8) 10mm Flat Washers and (4) 10mm Nylon Lock Nuts, **(Figures 13—14)**
 8. Properly level and adjust the Sidebar and fully tighten all hardware.
 9. **2009-12 models requiring drilling for driver side Support Brackets:**
 - a. Make sure the Sidebar is level to the vehicle. Adjust and tighten all mounting hardware.
 - b. Line up the slots on the Support Brackets with the back of the pinch weld. Mark the location of the slots onto the pinch weld.
 - c. Drill (2) 1/4" holes through the pinch weld for each Support Bracket. **IMPORTANT:** Do not drill too close to the bottom edge of the pinch weld. Adjust the Brackets as necessary to move the slots up the body panel away from the edge. Drill the holes toward the outside of the marked slots.
 - d. Attach each Support Bracket to the pinch weld with (2) 6mm Hex Bolts, (4) 6mm Flat Washers and (2) 6mm Nylon Lock Nuts, **(Figure 11)**. Level and adjust then fully tighten all hardware.
 10. Move to the Passenger/Right side of the vehicle. Remove tape covering front and rear locations. Repeat **Steps 2—9** for Passenger/Right side installation. **NOTE:** Refer to the illustration on **Page 1** to identify the correct Mounting Bracket for each location.
 11. Do periodic inspections to the installation to make sure that all hardware is secure and tight.

To protect your investment, Do not use any type of polish or wax that may contain abrasives that could damage the finish. Mild soap may be used to clean the Sidebars.

Driver/Left Side Installation Pictured

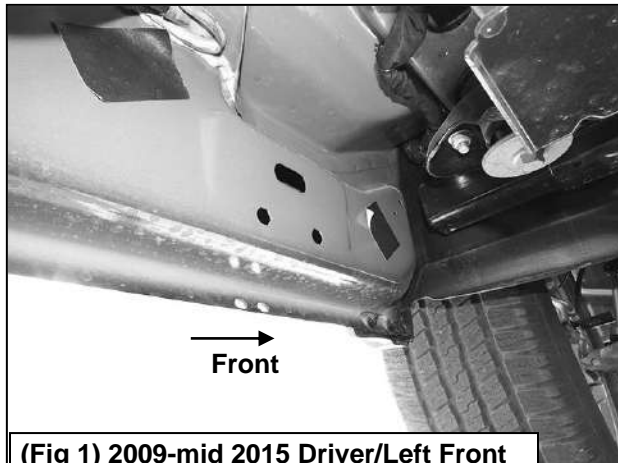

(Fig 1) 2009-mid 2015 Driver/Left Front mounting location (No factory holes in pinch weld 2009-2012 models)

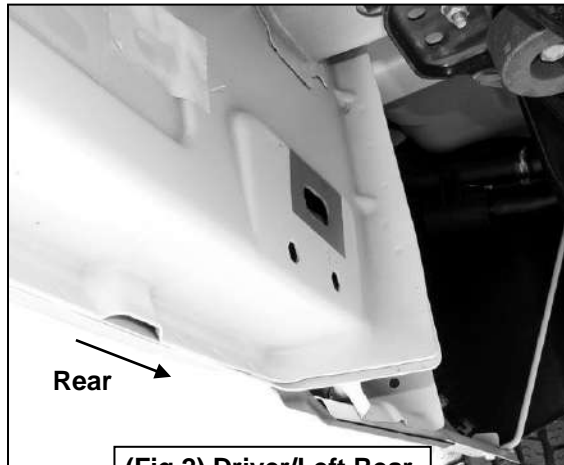

(Fig 2) Driver/Left Rear mounting location



(Fig 3) 8mm Bolt-8mm Nut Plate, NOTE: 8mm Bolt-Nut Plate is not required on models with threaded inserts

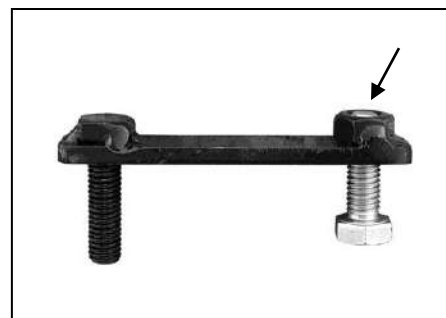

(Fig 4) Thread (1) 8mm Hex Bolt into the nut on the plate. Stop when bolt reaches end of nut as pictured

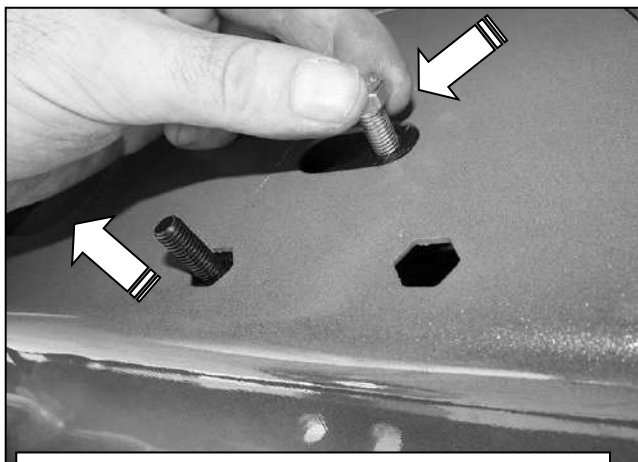

(Fig 5) Use the loose Hex Bolt as a handle. Insert the Bolt Plate into the oval hole and feed the threaded end out either factory hex shaped hole. IMPORTANT: Do not let go of the hex bolt until after Plastic Retainer has been threaded onto bolt Fig 6

Driver/Left Side Installation Pictured

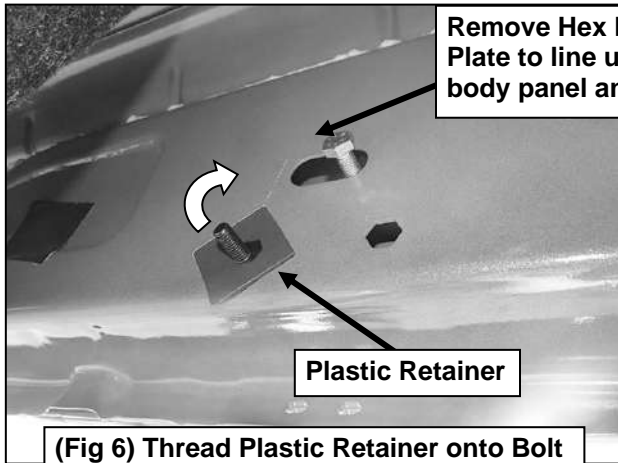

(Fig 6) Thread Plastic Retainer onto Bolt Plate to hold Bolt Plate in position.

8mm Flat Washer
8mm Lock Washer
8mm Hex Nut

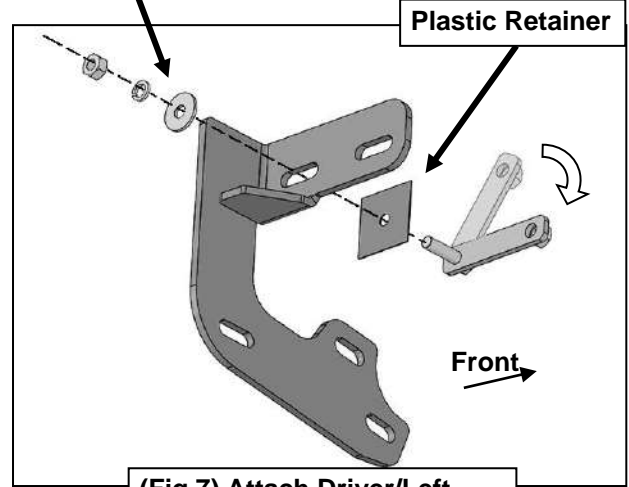

(Fig 7) Attach Driver/Left Front Bracket to Bolt Plate (Driver front pictured)

8mm Hex Bolt
8mm Lock Washer
8mm Flat Washer

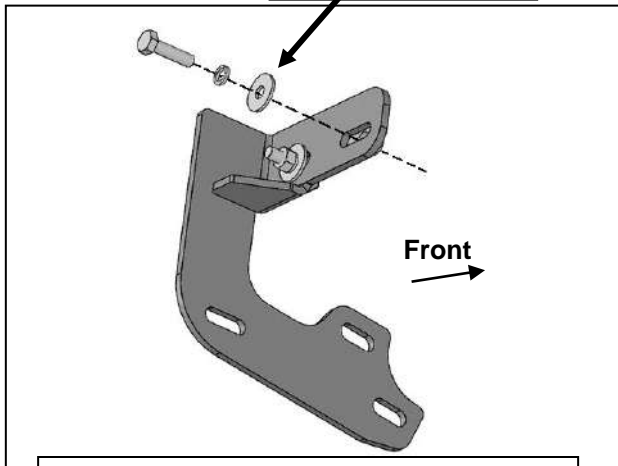

(Fig 8) Attach Bracket to threaded end of Bolt Plate first. Remove 8mm Hex Bolt (see Fig 3). Rotate Bolt Plate to line up with remaining factory hex shaped hole.

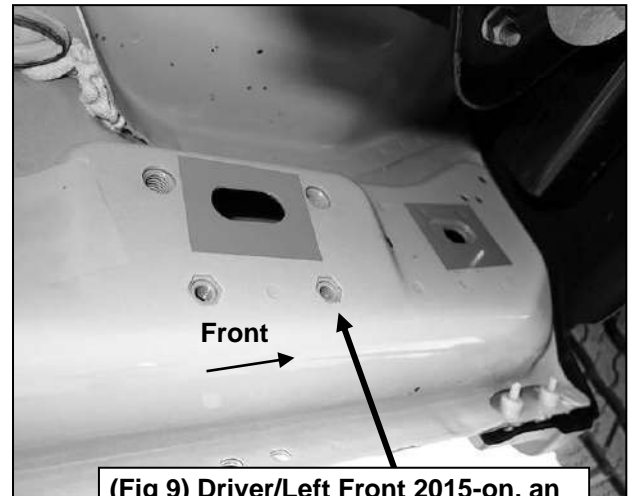

(Fig 9) Driver/Left Front 2015-on, an example of models with factory installed threaded inserts

Driver/Left Side Installation Pictured

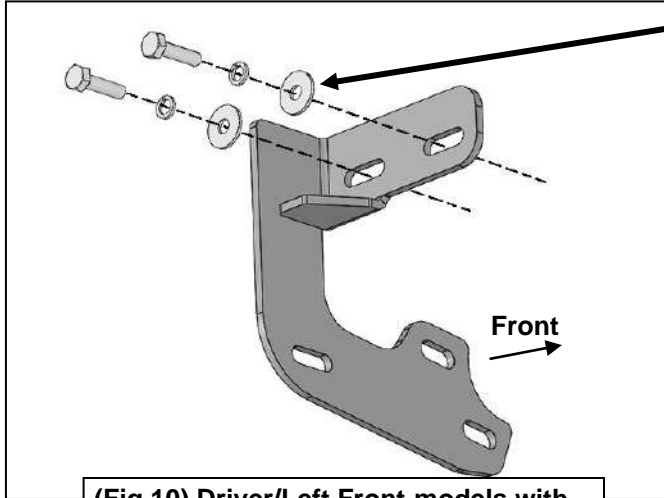

- (2) 8mm Hex Bolts
- (2) 8mm Lock Washers
- (2) 8mm Flat Washers

(Fig 10) Driver/Left Front-models with factory installed threaded inserts. Bolt Plate not required

IMPORTANT: 2009-2012 models without holes in pinch weld will require drilling 1/4" holes through pinch weld to attach driver side front support bracket. Do complete installation of sidebars first, level sidebar before drilling holes for support bracket.

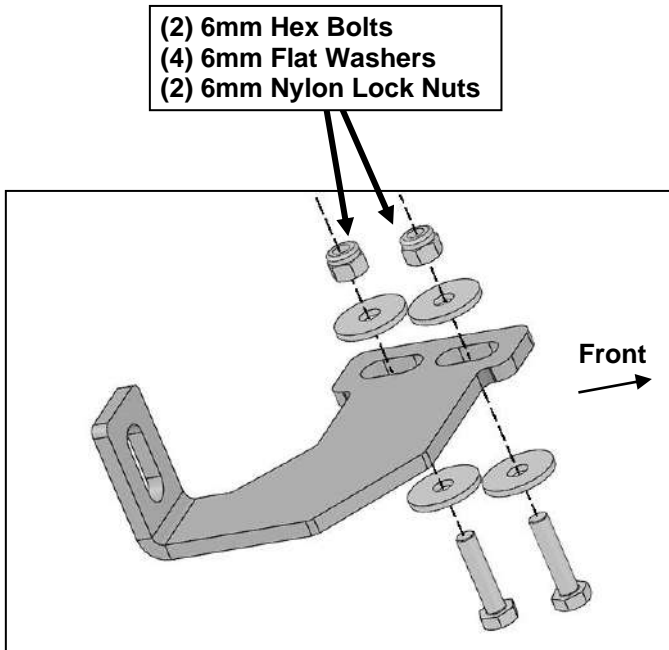

- (2) 6mm Hex Bolts
- (4) 6mm Flat Washers
- (2) 6mm Nylon Lock Nuts

(Fig 11) Attach Support Bracket to back of pinch weld (models with factory holes in pinch weld only)

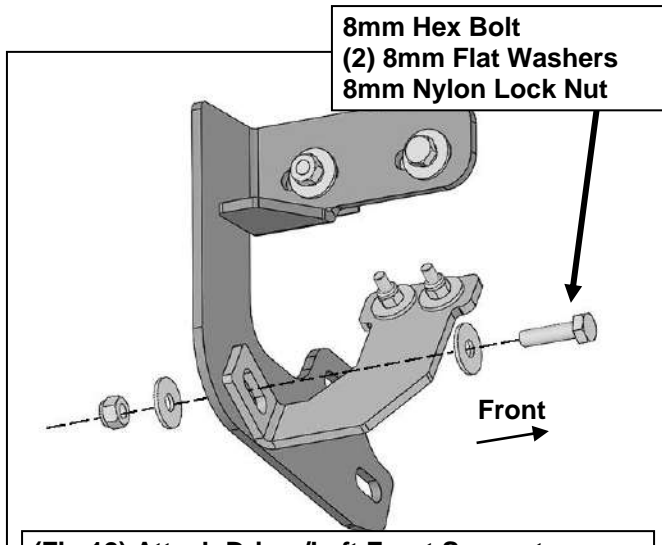

- 8mm Hex Bolt
- (2) 8mm Flat Washers
- 8mm Nylon Lock Nut

(Fig 12) Attach Driver/Left Front Support Bracket to front facing side of Mounting Bracket

Driver/Left Side Installation Pictured

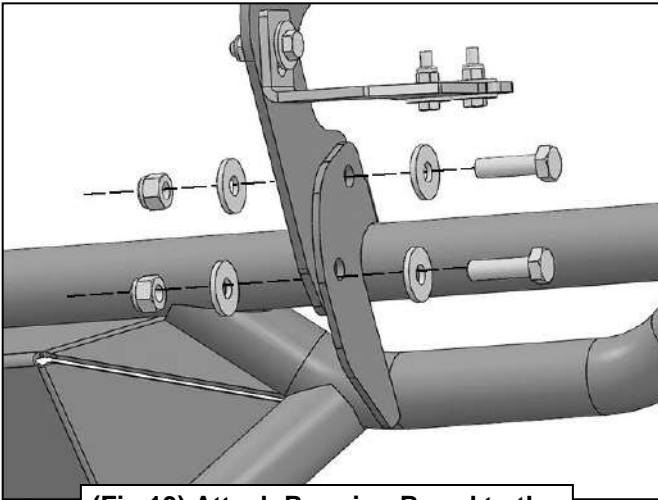

(Fig 13) Attach Running Board to the front face of the mounting bracket

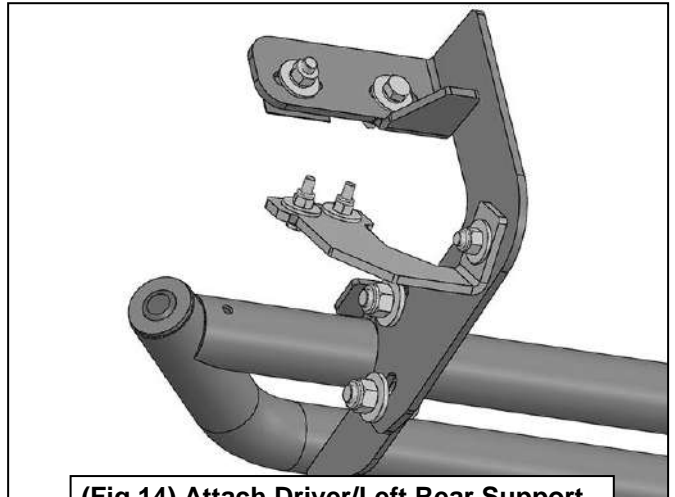

(Fig 14) Attach Driver/Left Rear Support Bracket to rear facing side of Mounting Bracket (Installation complete in picture)



Installation Complete