

**PARTS LIST:**

1	Driver/left Running Board	24	10mm x 30mm Hex Bolts
1	Passenger/right Running Board	60	10mm x 27mm x 3mm Flat Washers
6	Mounting Brackets	24	10mm Lock Washers
12	10mm Clip-on Nuts	12	10mm Hex Nuts
12	10mm x 35mm Hex Bolts	12	10mm Nylon Lock Nuts

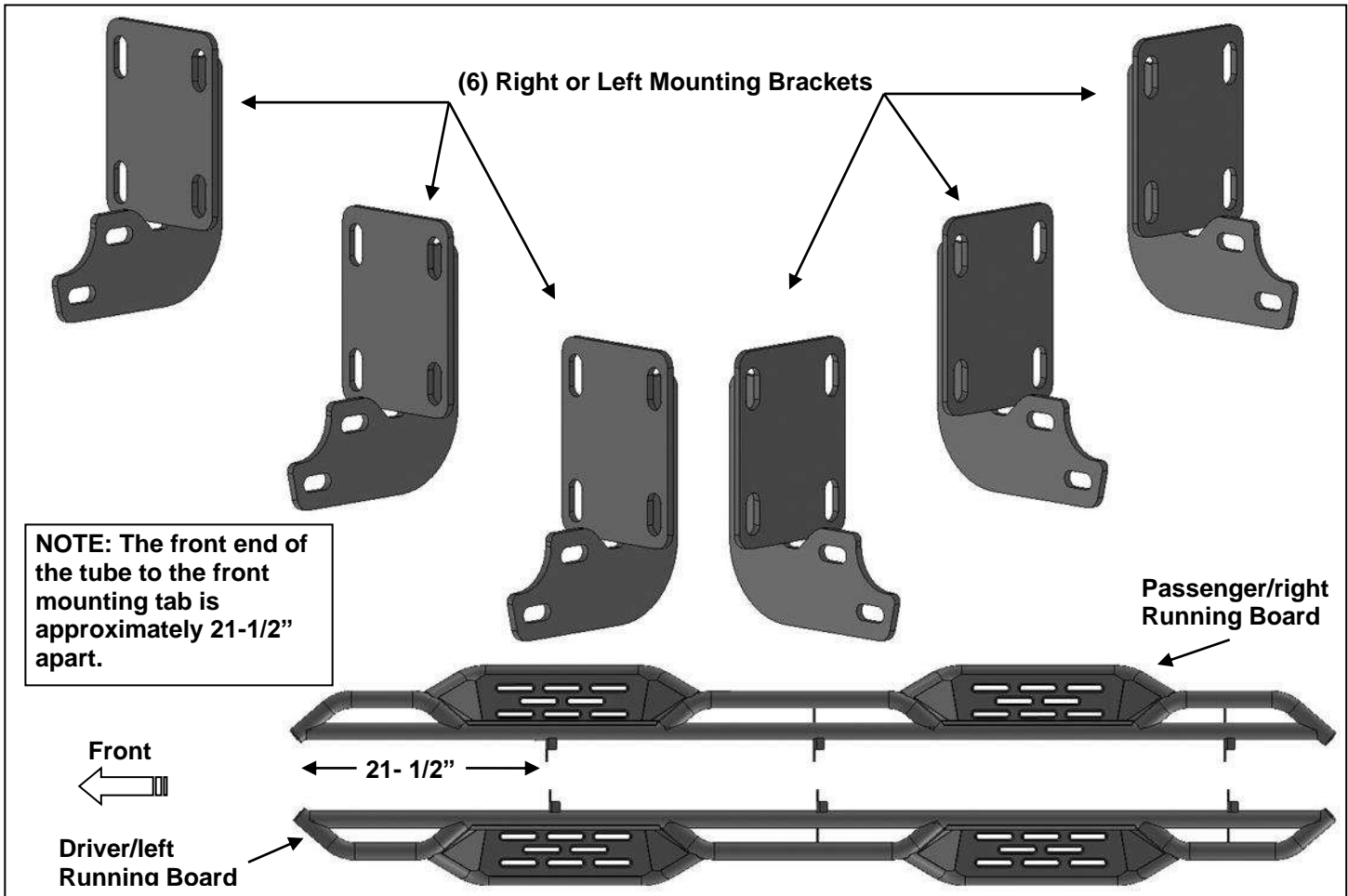

**PROCEDURE:**

- 1. REMOVE CONTENTS FROM BOX. VERIFY ALL PARTS ARE PRESENT. READ INSTRUCTIONS CAREFULLY BEFORE STARTING INSTALLATION. ASSISTANCE IS RECOMMENDED.**
- Starting on the passenger/right side-front of the vehicle, locate the (5) pairs of factory holes along the pinch weld. Move to the 2nd pair of holes directly under the center of the front door, **(Figures 1 & 2)**. **NOTE:** There are (5) mounting locations along the inner body panel. Running Board installation will use the 2nd, 3rd and 5th mounting locations, **(Figure 1)**.
- Select (2) 10mm Clip Nuts. Insert Clip Nuts one at a time into the rectangular opening and slide the threaded hole outward towards the round hole. Line up the threaded hole in the clip with the round hole next to the rectangular opening. **NOTE:** Threaded nut must go towards the inside of the side panel, **(Figures 3 & 4)**.
- Select (1) Mounting Bracket. **NOTE:** All (6) Brackets are universal and will fit left or right side. Attach the Bracket to the Clip Nuts with the included (2) 10mm x 30mm Hex Bolts, (2) 10mm Lock Washers and (2) 10mm Flat Washers, **(Figures 5 & 6)**.
- Attach the (2) bottom holes in the Mounting Bracket to the (2) holes in the pinch weld with the included (2) 10mm x 30mm Hex Bolts, (4) 10mm Flat Washers, (2) 10mm Lock Washers and

- (2) 10mm Hex Nuts, **(Figures 5 & 6)**. **NOTE:** Insert the Hex Bolt with Flat Washer through pinch weld first then through the Bracket from outside to inside. Do not tighten hardware.
6. Move along the vehicle to the next, (center), mounting location, **(Figure 7)**. Repeat **Steps 2—5** to install (1) Bracket in the center location, **(Figure 8)**.
  7. Move along the cab to the last mounting location. Repeat **Steps 2—6** to install (1) Bracket in the last location at the back of the cab, **(Figure 9)**.
  8. Select the passenger/right side Running Board. **NOTE:** Use the illustration above to properly identify the passenger/right Running Board.
  9. With assistance, carefully position the Running Board to the rear facing side of the (3) Mounting Brackets. Attach the Running Board to the Brackets with (6) 10mm x 35mm Hex Bolts, (12) 10mm Flat Washers and (6) 10mm Nylon Lock Nuts, **(Figures 10—12)**. Do not tighten hardware at this time.
  10. Level and adjust the Running Board and tighten all hardware.
  11. Repeat **Steps 2—10** for driver/left Running Board installation.
  12. Do periodic inspections to the installation to make sure that all hardware is secure and tight.

**To protect your investment**, wax this product after installing. Regular waxing is recommended to add a protective layer over the finish. Do not use any type of polish or wax that may contain abrasives that could damage the finish. Mild soap may be used to clean the Running Board.

### Passenger/right Side Installation Pictured

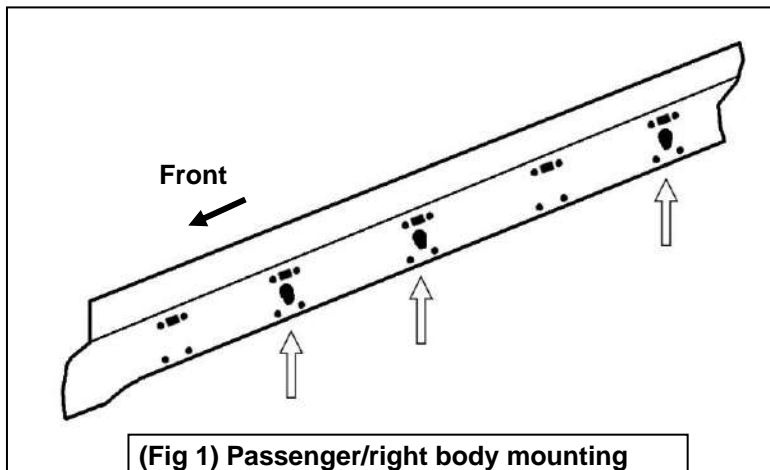

**(Fig 1) Passenger/right body mounting locations illustrated back of rocker panel**

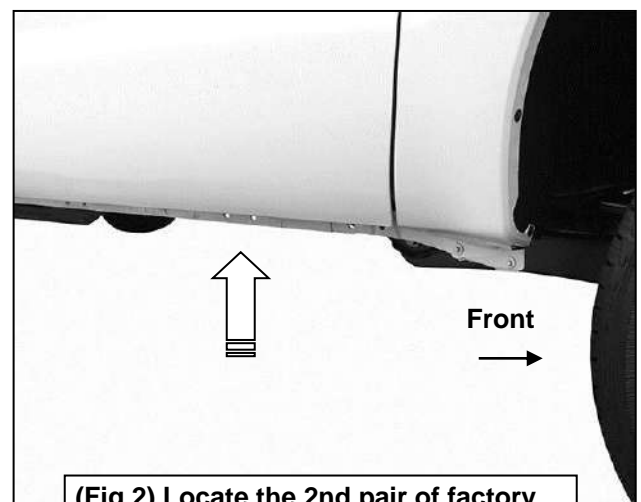

**(Fig 2) Locate the 2nd pair of factory holes in the bottom of the pinch weld**

**Passenger/right Installation Pictured**

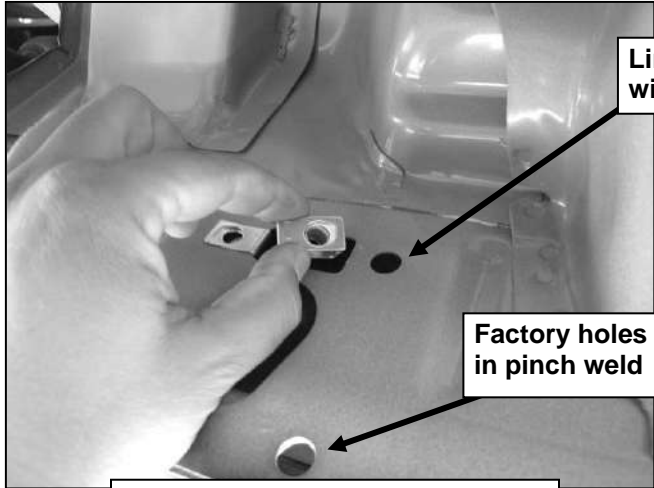

Line up Clip Nut with factory hole

Factory holes in pinch weld

(Fig 3) Typical Mounting Location

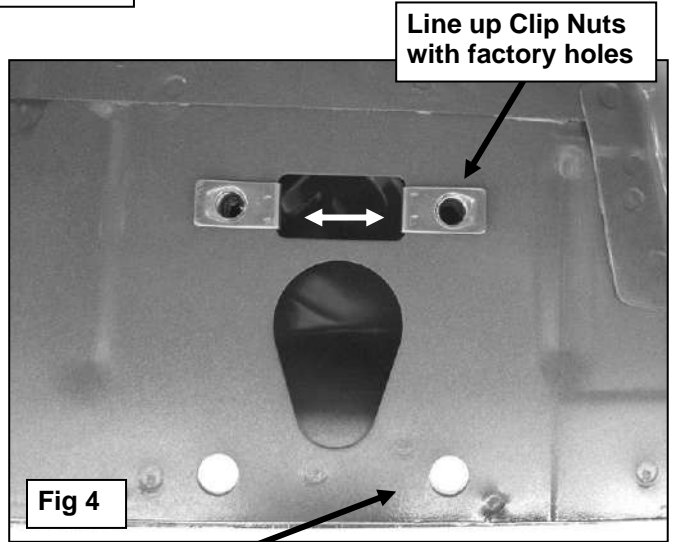

Line up Clip Nuts with factory holes

Fig 4

Factory holes in pinch weld pictured from behind body panel

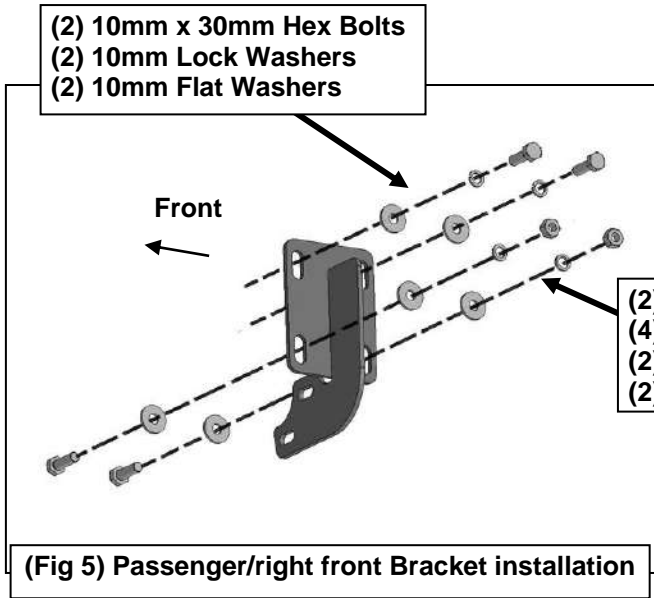

- (2) 10mm x 30mm Hex Bolts
- (2) 10mm Lock Washers
- (2) 10mm Flat Washers

Front

- (2) 10mm x 30mm Hex Bolts
- (4) 10mm Flat Washers
- (2) 10mm Lock Washers
- (2) 10mm Hex Nuts

(Fig 5) Passenger/right front Bracket installation

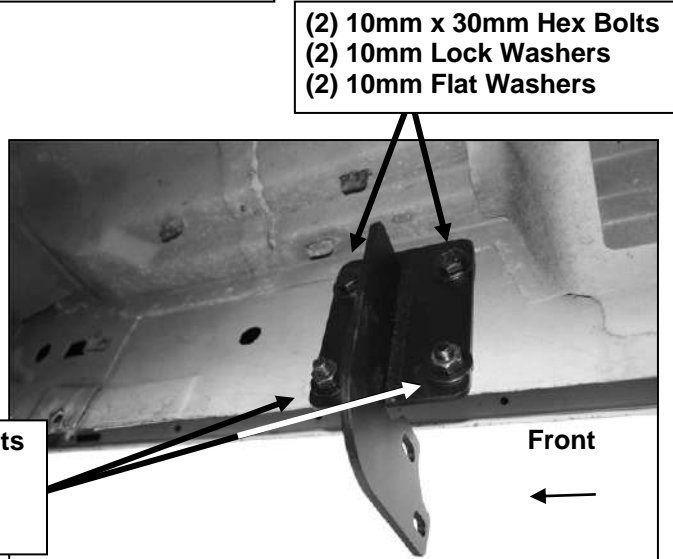

- (2) 10mm x 30mm Hex Bolts
- (2) 10mm Lock Washers
- (2) 10mm Flat Washers

Front

- (2) 10mm x 30mm Hex Bolts
- (4) 10mm Flat Washers
- (2) 10mm Lock Washers
- (2) 10mm Hex Nuts

(Fig 6) Passenger/right front Bracket installation

### Passenger/right Installation Pictured

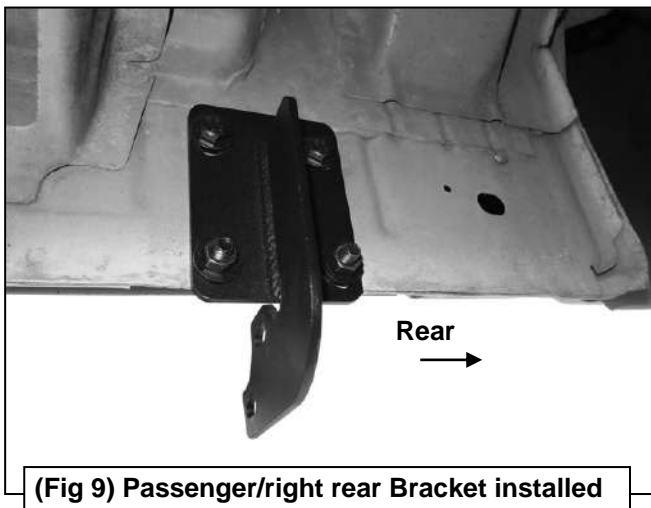
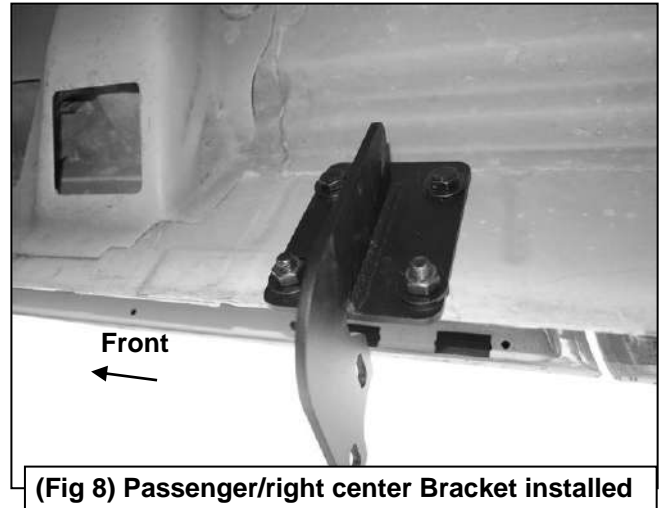

- (2) 10mm x 35mm Hex Bolts
- (4) 10mm Flat Washers
- (2) 10mm Nylon Lock Nuts

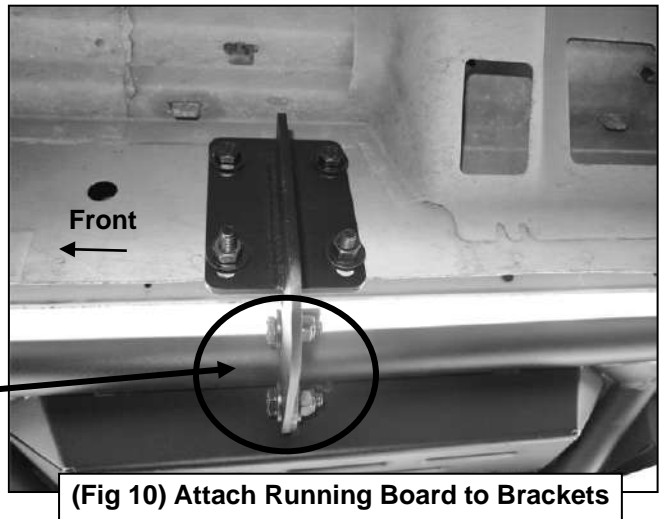

### Passenger/right Installation Pictured

